



WALTCO

www.waltco.com
parts@waltco.com

Phone: 800.411.5685
Fax: 800.411.5684

Owner's Manual

WDV, WDVBG

Gen 2

3500, 4500, 5500, 6600 lb. Capacity Rail-Type Liftgates

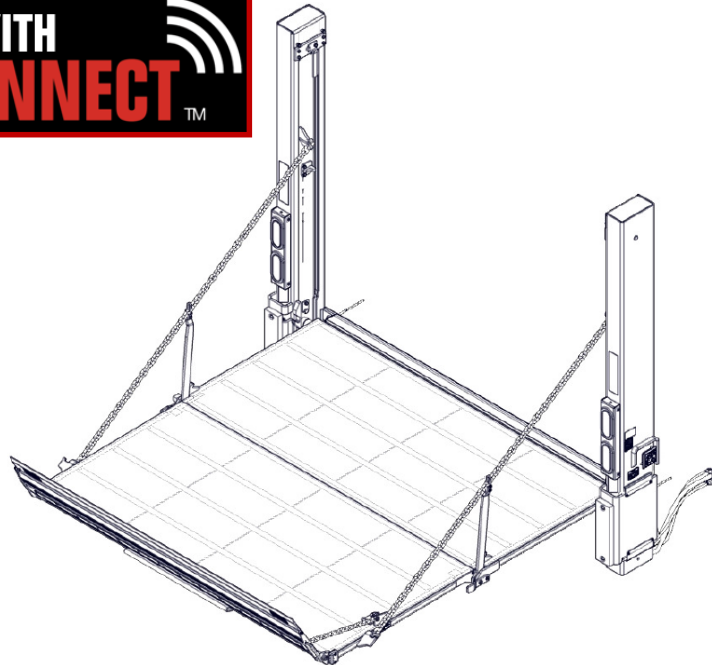

Last Change(s)

Date	Page(s)	Description
9-2020	All	Converted to Online Format
	4	Added HiConnect as standard feature
	21	Motor oil no longer recommended as hydraulic fluid
	20, 21	Clarified oil replacement and fill instructions
	22	Added HiConnect Decal
	23	Added alternate decal placement page
	25 - 28	Revised schematics and added SPPD schematic 80101715

Waltco Lift Corp.
Corporate Office United States
1777 Miller Parkway
Streetsboro, OH 44241
P: 330.633.9191
F: 330.633.1418

EO:10578 Rev 03
02-2021

80142702

Table of Contents



Improper operation and maintenance of this liftgate could result in severe personal injury or death.

Read and understand the contents of this manual and all warning and operation decals before operating and/or performing maintenance on this liftgate.

Introduction.....	3
HiConnect Telematics Unit Information.....	4
Safety Information.....	5
Warranty Information.....	7
Liftgate Terminology.....	8
Operation Instructions.....	12
Preventative Maintenance.....	17
Placement of Decals.....	22
Lubrication Instructions.....	24
Single Power Unit Schematic.....	25
Single Power Unit With Gravity Down Schematic.....	26
Dual Power Unit With Backup/Auxiliary Schematic.....	27
Dual Power Unit With Gravity Down With Backup/Auxiliary Schematic.....	28
How to Order parts.....	29

Introduction

If anyone observes improper installation, improper operation, or damage, they should immediately contact a qualified person for assistance and correction. We strongly urge anyone that has any questions or doubts as to the installation, condition, use, operation, maintenance or repair of the liftgate to contact us at Waltco where we have qualified personnel that will be happy to assist you. Telephone numbers and addresses of these locations are listed in the Owner's Manual and Installation Instructions.

INSTALLATION

Waltco liftgates should only be installed by those with sufficient basic skills to understand the installation and operation of the liftgate, along with the equipment on which the liftgate is being installed. Waltco's installation instructions are not intended to give rationale for all the instructions that are given; however, it is the intent of these instructions to give the installer both the operations and what we believe to be the most desirable sequence of implementing these operations. These instructions can in no way expand into an area where they will replace a qualified person, or clear thinking and a basic knowledge that must be possessed by the installer.

It has been our experience that a knowledgeable journeyman following these instructions and observing the operation of the liftgate will have a sufficient comprehension of the liftgate to enable this person to troubleshoot and correct all normal problems that may be encountered.

Failure to follow the installation instructions, adjustments and mounting dimensions may result in improper and unsafe operation of the liftgate. Unauthorized alterations of the liftgate can cause an undesirable and dangerous condition.

OWNER'S MANUAL

The Waltco Owner's Manual is intended to act as a guide for operation and routine maintenance but is no way intended to encourage usage or repair of the liftgate by those who are not qualified to do so.

The contents of the Owner's Manual include, but are not limited to general operation instructions, routine lubrication, parts list, and an outline of things that should be checked but may not be obvious to those not technically qualified. The manual assumes the liftgate is properly installed, undamaged and operates correctly. Improper installation, improper operation, or damage should be immediately corrected by a qualified person.

INSPECTION

As part of the regular inspection of a liftgate and after damage or suspicion of an overload, inspect for wear or structural damage and make necessary repairs or replacements. Check all structural components and their attachment to the liftgate for cracked welds, loose fasteners, wear and part deformation. Check cylinder and hose for leaks. Inspections and repairs should be made by a qualified mechanic.

REPLACEMENT PARTS

Use only Waltco original equipment replacement parts. Components of other liftgate manufacturers may outwardly appear to be the same but are not interchangeable with Waltco products. Waltco components are specifically designed for safety requirements, reliability and compatibility with our products. Refer to your Waltco Parts Manual when ordering parts. NOTE: When ordering, give model and serial number for liftgate.

DECALS

It is important that every vehicle that has a WALTCO Liftgate have legible DECALS clearly posted on the vehicle and an OWNER'S MANUAL in the vehicle at all times as a guide for proper operation and maintenance. Additional DECALS and OWNER'S MANUALS can be obtained from WALTCO LIFT CORP.

80101388

Rev 04 EO10758

HIAB HICONNECT TELEMATICS UNIT

The HiConnect unit is a factory installed telematics unit that provides real time telemetry of liftgate operation. This telemetry is invaluable to users seeking to gather data on vehicle routes and gain greater liftgate uptime through enhanced preventative maintenance.

You may go to <http://hiab.com/en-US/pages/hiab-hiconnect/registration/hiconnect-registration> to register the unit, or use the QR code below:



The liftgate serial number is required for setup.

After registration is complete, call Waltco Service at 1-800-211-3074. One of our team members will finalize the setup and guide you through HiConnect's features.

Legal Statement:

Hiab shall at all times have the right to (i) install, maintain and dismantle remote diagnostics tools or similar sensor-based connectivity capabilities ("Connectivity") in and from the Equipment; and (ii) access, send, receive, collect, store and use any and all information and data gathered through the Connectivity, including but not limited to, information concerning efficiency, availability, downtime, operation, operating environment, movement, condition, logon, location and similar information relating to the Equipment (the "Information"). Such Information may be used for optimizing the Equipment, or any related equipment or services as well as for Hiab's internal business and/or operating purposes. Hiab shall be responsible for complying with applicable laws and regulations related to such Information

Customer/user shall not in any way remove, disable, or interfere with the Connectivity or the Information. Any intellectual property rights or other right and title in and to the Connectivity features and the Information and all their further developments shall at all times be and remain the exclusive property of Hiab.

Chapter 1 Safety Information

! WARNING

Read, understand, and follow all of the warnings listed below.

Failure to follow these warnings could result in severe personal injury or death.

- * Read and understand the Owner's Manual, all decals and warnings on liftgate before operating liftgate.
- * Do not operate liftgate without a thorough knowledge and understanding of the operation of the liftgate.
- * Liftgate hazards can result in crushing or failing.
- * This liftgate is designed for loading and unloading cargo. If personnel are required to ride the liftgate, observe and familiarize yourself with the liftgate operation, decals and manuals. Ensure stable footing at all times.
- * Do not ride liftgate with unstable loads.
- * Wheeled loads must be properly retained from rolling.
- * Tall, high center of gravity loads must be retained from falling over.
- * **Never overload liftgate:**
Load platform as close to the vehicle and towards the middle of the platform as possible. Refer to Owner's Manual and capacity decal of liftgate for maximum load and load placement.
- * Keep hands and feet clear of all potential pinch points.
- * Never use liftgate if it shows any signs of structural damage such as cracked welds, bent or distorted members.
- * Do not attempt any repairs unless you are qualified to do so. Care should be taken when work is performed on a disabled liftgate located near moving traffic. When possible, the vehicle should be moved away from traffic areas for repair. Precautionary measures should be taken to ensure personal safety including those recommended in Federal Motor Vehicle Safety Standards 571.125.
- * When welding to liftgate, or liftgate components, take all necessary safety precautions, including using respiratory protection and other pertinent personal protective gear when welding harmful materials.
- * All protective covers, guards, and safety devices must be in place and access doors closed before operating liftgate.
- * Do not allow anyone to stand in or near area in which Platform will open and close before opening and closing Platform.
- * Do not allow anyone to stand near the Platform where a falling load could land on them.
- * Platform is always to be properly stored and secured for transit. See the Owner's Manual for details.
- * Take care to retain cargo during transit for liftgate Platforms which function as the tailgate or door of the cargo area. Small objects can fall through the space between the vehicle and the folded Platform.
- * A Lock-Out device or Shut-Off Switch should always be used to prevent unauthorized use of liftgate.
- * For liftgates with Runners, never use liftgate if Runners do not travel up or down freely and smoothly.
- * For liftgates with Roller Lifting Chain, the Chain should be replaced every (5) five years or 15,000 cycles, whichever comes first. Replace only with Walco approved Roller Chain.
- * Never transfer loads which exceed lifting capacity on or over any part of the Platform or Bed Extension unless the liftgate is equipped with a special reinforced Platform and Platform Support Bars for use when the Platform is used as a loading ramp (dock board). Refer to the "Using Platform as a loading ramp" Chapter in the Operation Instructions of the BZ/RZ series Owner's Manual.
- * For liftgates equipped with Trailer Hitches, never exceed the rated capacity of the hitch. Do not exceed the vehicle's weight rating. Refer to the vehicle's Owner's Manual.
- * Vehicle must comply with all state and federal standards.
- * Follow the "Maintenance Guide" chapter in the Owner's Manual.

80101253

Rev 05 EO10758

Chapter 1 Safety Information

Liftgates with Tilt Function

- * Proper use of the Control Switches is of extreme importance.
- * Improper use of Tilt Switch could cause load to fall from the Platform or damage the liftgate.
- * Platform should be in a generally horizontal position when raising or lowering with a load.
- * In any tilt position, the Platform may vary from level while raising or lowering the Platform.

Liftgates equipped with spring operated Cam Closer

- * Replace Cam Release Spring every (5) five years or 15,000 cycles, whichever comes first.

RGL Series Liftgates

- * Make certain Platform Brake mechanisms are operating properly.
- * The Runners are always to remain powered up against the Upstop Pins when in transit.
- * Inspect cables every (3) three months or 750 cycles, whichever comes first. Cables must be replaced if they show signs of wear, distortion, kinking or if any broken wires are visible.
- * Replace cables every (5) five years or 10,000 cycles, whichever comes first.

MDL Series Liftgates

- * Make certain Platform Brake mechanisms are operating properly.
- * The Platform Retaining Bar should be lowered into H-Frame Storage Plate when in transit.
- * Inspect Roller Chains every (3) three months or 750 cycles, whichever comes first. Roller Chains must be measured and checked for signs of stretching. If the chain is stretched by more than 3% they should be replaced.
- * Replace Roller Chains every (5) five years or 15,000 cycles whichever comes first. Replace only with WALTCO APPROVED Roller Chain.
- * Check that all connecting links at each end of Roller Chain are properly secured with proper cotter pins monthly.



This is the Safety Alert Symbol. This manual uses this symbol to alert you to potential personal injury hazards. Obey all safety messages that follow this symbol to avoid personal injury or death.

SIGNAL WORDS

WARNING

Indicates a potentially hazardous situation, which if not avoided, could result in death or serious injury.

Black letters on an orange background.



CAUTION

Indicates a potentially hazardous situation, which if not avoided, may result in minor or moderate injury.

May also be used to alert against unsafe practices.

Black letters on an yellow background.



NOTICE

Indicates a potentially hazardous situation, which if not avoided, could result in property damage.



WALTCO warrants its products free of defects in materials and workmanship.

WALTCO will replace components found defective during the warranty period. Labor will be reimbursed according to our flat rate labor schedule at the prevailing shop rate.

Contact our Sales or Warranty departments for the warranty period of your model or for information regarding our flat rate labor schedule.

WALTCO Warranty Claim Procedure

For consideration, all claims must be received within 30 days of repair and include the following information:

- Liftgate Serial Number
- Description of problem and corrective actions
- Itemization of the labor charge to include the number of hours and labor rate

Replacement warranty parts can be obtained by contacting Waltco's Parts Department. Parts must be returned for inspection when requested.

Exclusions:

Waltco's warranty does not include reimbursement for service calls, vehicle rental, towing, travel time, fabrication of parts available from WALTCO, damage from misuse or abuse, negligence, accidents, alteration, loss of income or overtime expense, oil, or normal wear.

Diagnosis and troubleshooting time are included in the flat rate labor times.

Warranty and technical information is available from WALTCO's toll free customer service lines from 8:00 a.m. to 5:00 p. m. EST.

Waltco Lift Corp

1777 Miller Parkway

Streetsboro OH, 44241

Sales Direct Line: 1-800-211-3074

Parts Direct Line: 1-800-411-5685

www.waltco.com

We're behind you all the way!

EO: 7714 Rev 01

80101667

5-2015

Chapter 2 Liftgate Terminology

MODEL NAME	DESCRIPTION	CAPACITY
WDVBG35	WDVBG-35 Series	3500 lb.
WDVBG45	WDVBG-45 Series	4500 lb.
WDV35	WDV-35 Series	3500 lb.
WDV45	WDV-45 Series	4500 lb.
WDV55	WDV-55 Series	5500 lb.
WDV66	WDV-66 Series	6600 lb.

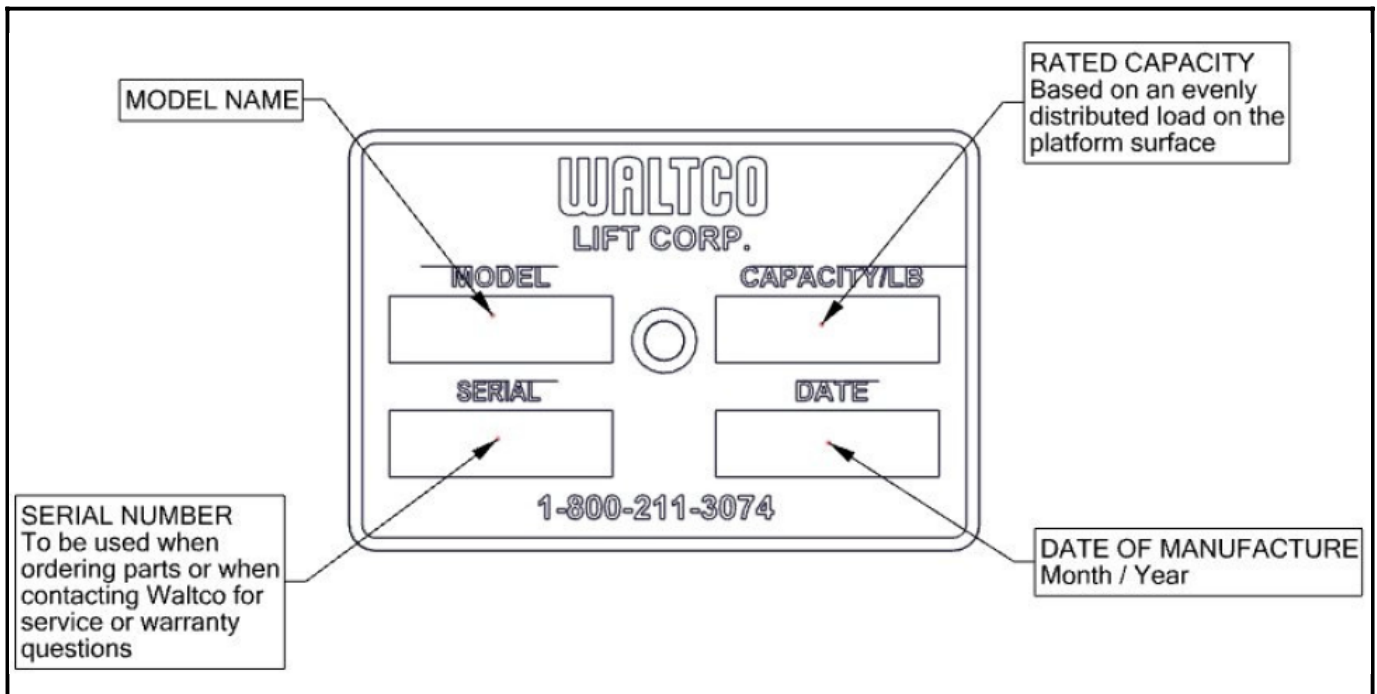

Chapter 2 Liftgate Terminology

- | | | |
|------------------------|---------------------------|--------------------------------|
| 1. Curb Side Column | 8. Bottom Stop Catch | 15. Closing Cylinder |
| 2. Drivers Side Column | 9. Deck | 16. Drivers Side Lift Cylinder |
| 3. Lights | 10. Deck Extension | 17. Curb Side Lift Cylinder |
| 4. Inside Switch | 11. Flip Ramp Assembly | 18. Specification tag |
| 5. Sill Extension | 12. Drivers Side Runner | 19. Dock Bumper |
| 6. Support Chain | 13. Curb Side Runner | |
| 7. Swing Arm | 14. Outside Column Switch | |

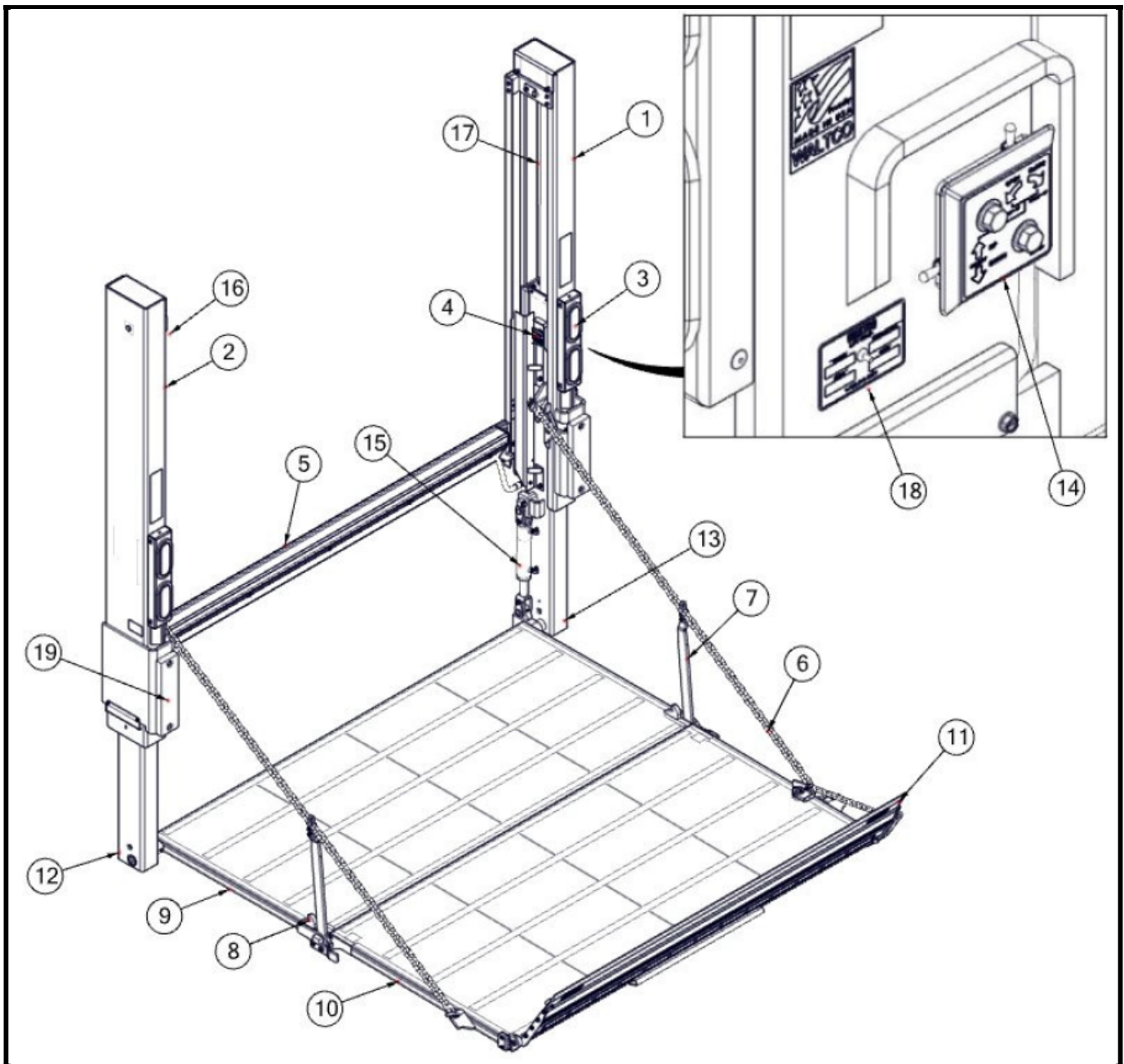

Chapter 2 Liftgate Terminology

- | | |
|--------------------------------------|----------------------------------|
| 20. Pump Box Lid | 27. Backup Controls |
| 21. Battery Box Lid | 28. 150 Amp Manual-Reset Breaker |
| 22. Pump Box Base | 29. 150 Amp Auto-Reset Breaker |
| 23. Battery Box Base | 30. 15 Amp Auto-Reset Breaker |
| 24. Primary Motor and Pump | 31. Master Disconnect Switch |
| 25. Backup Motor and Pump (Optional) | 32. HiConnect Unit (not shown) |
| 26. Manifold Block Assembly | |

Note: Dual motor power box is shown

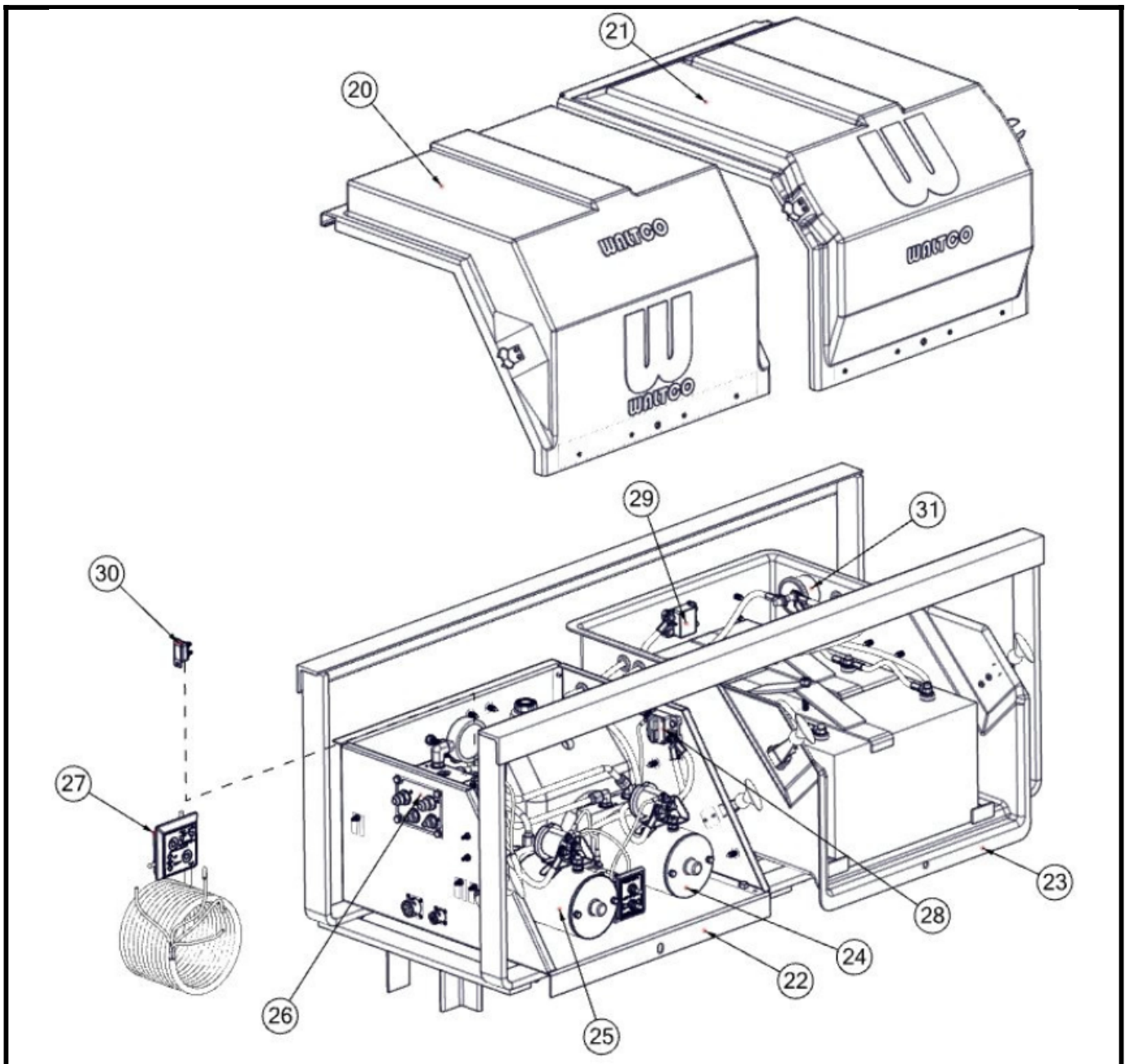

Chapter 2 Liftgate Terminology

- 32. Side Rail Assembly
- 33. Outer Guard Rail Assembly
- 34. Guard Rail Latch Assembly
- 35. Inner Guard Rail Assembly
- 36. Ramp Assembly
- 37. Gas Bottle Retention Chain

WDVBG

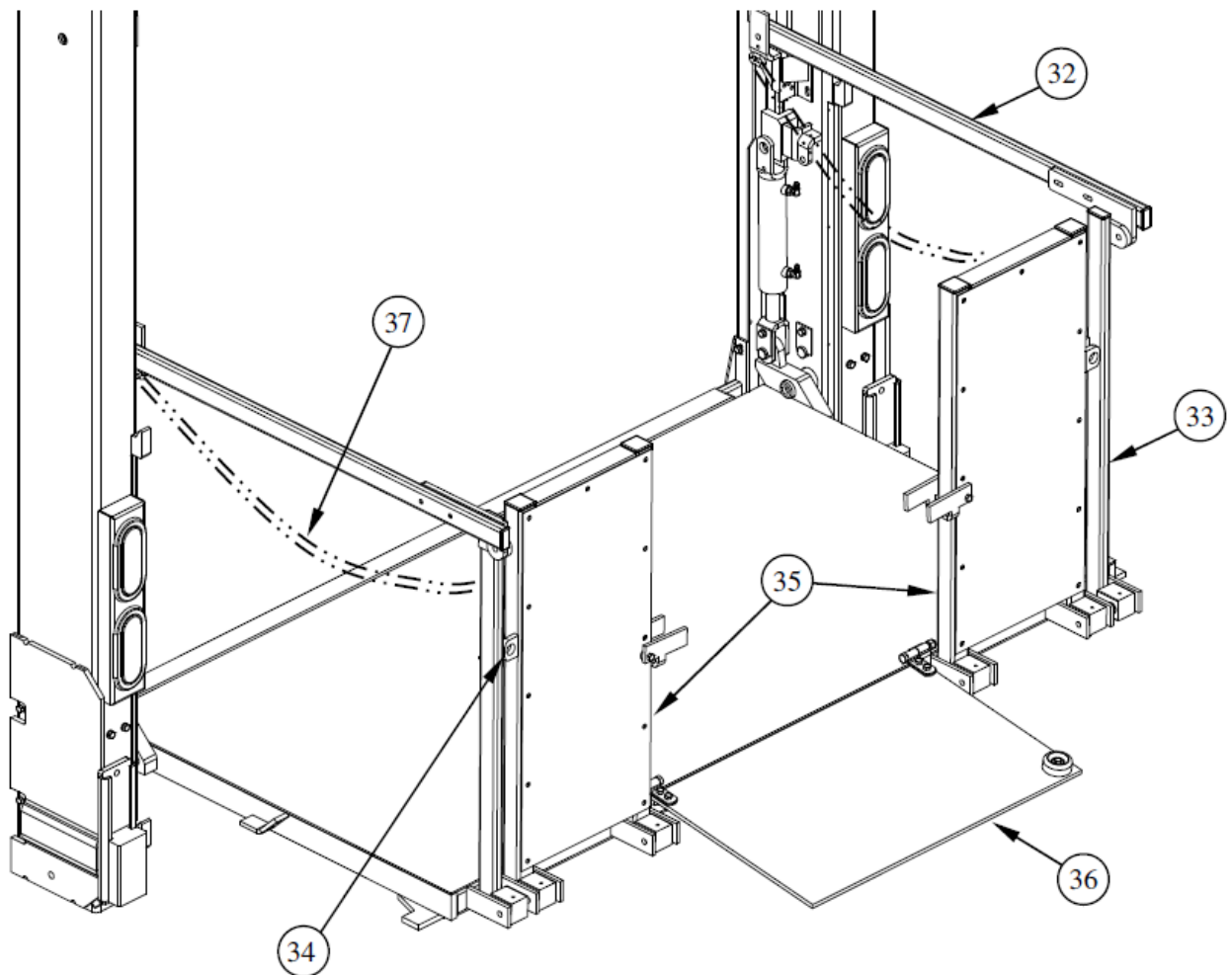

Chapter 3 Operation Instructions

OPERATION INSTRUCTIONS



Read and understand these instructions, all warning and operation decals, and this manual before operating this liftgate.

When in transit, Platform must be in stored position with Travel Ears in Travel Locks.

Do not allow anyone to stand in, or near area, in which Platform will open and close before opening or closing Platform.

Do not allow anyone to stand near the Platform where a falling load could land on them.

Platform Swing Arm areas must be kept clear for Platform opening and closing.

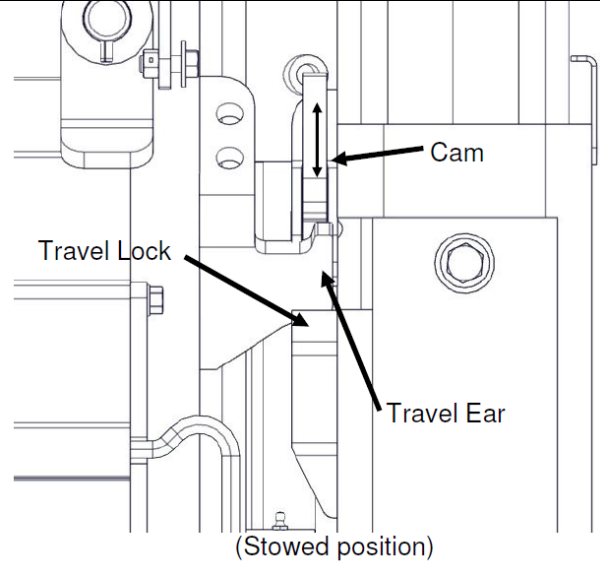

LOADING OF PLATFORM



Load and unload from rear of platform and not side of platform. Never remove lift chains or swing arms to load or unload platform.

Always load as close to center of platform and as close to truck sill as possible.

Never operate fork lifts on or over any part of platform.

This unit is intended for loading and unloading of cargo only. Do not use for anything but its intended use.

RAISING AND LOWERING OF PLATFORM

Using the "DOWN" toggle switch, lower platform for use.

Use the "UP" toggle switch to raise platform.



Ensure platform and flip ramp are fully lowered when loading and unloading platform at ground level.

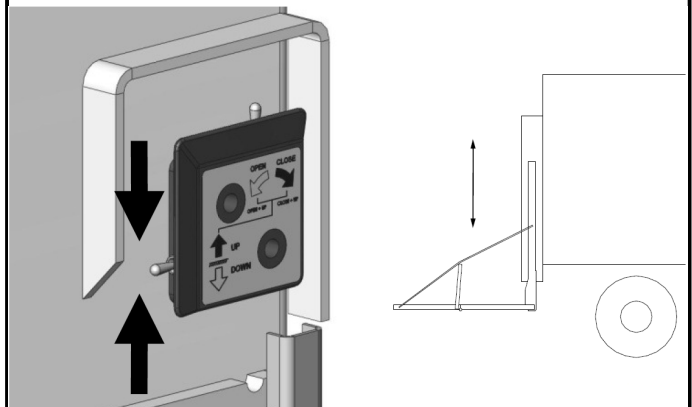

Chapter 3 Operation Instructions

CLOSING AND OPENING PLATFORM

1. With the platform open, power platform all the way up using the "UP" toggle switch and "CLOSE" toggle switch simultaneously, power close platform.
2. Push the "UP" toggle switch and the "OPEN" toggle switch simultaneously to power open the platform.

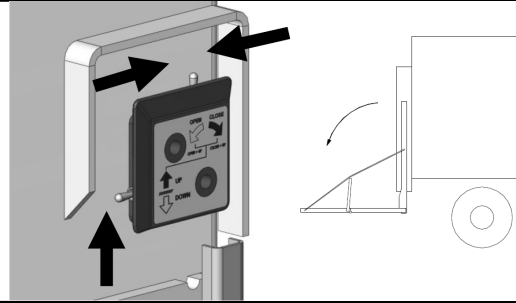

STORING PLATFORM FOR TRAVEL

1. Using the "DOWN" toggle switch, power platform down past the Travel Lock.
2. Using the "UP" toggle switch, power platform up to lift the Lock Cam.
3. Power platform up until Travel Ear clears the Travel Lock slot.
4. Use the "DOWN" toggle switch to lower Travel Ear into the Travel Lock slot.
5. Turn off power to liftgate by turning the master disconnect switch, located on battery box, to the "OFF" position.

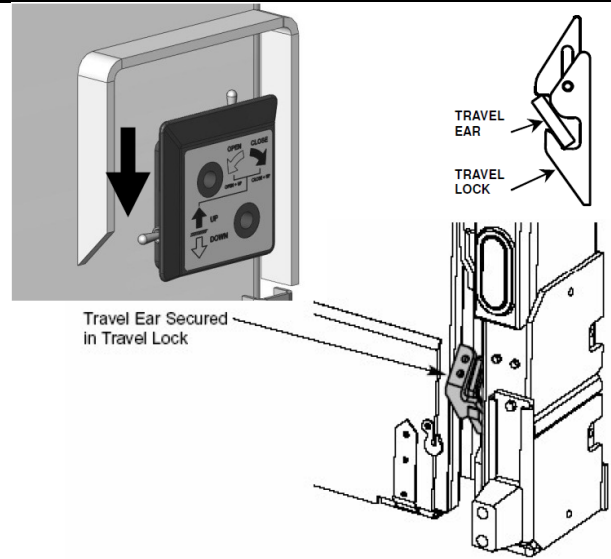

LOWERING PLATFORM FOR DOCK LOADING

1. Turn on power to Liftgate by turning the master disconnect switch, located on battery box, to the "ON" position.
2. Using the "UP" toggle switch, power platform up so that it is completely out of the travel locks.
3. Using the "DOWN" toggle switch, power platform down until the platform is level with the truck floor and hit the Dock Stops.
4. When finished Dock Loading be certain to store the platform in the travel latches before pulling truck away from dock.

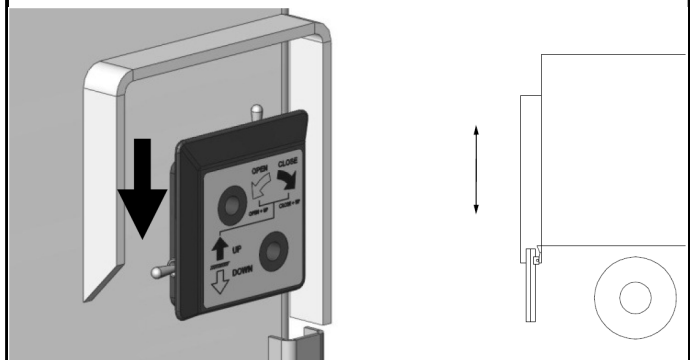

Chapter 3 Operation Instructions

FOLDING RAMP OPTION OPERATION INSTRUCTIONS

1. Unlatch ramp and unfold to loading position.
2. Use flip ramp chain for cart stop application.
3. Assure ramp is latched when in transit position.



Ensure platform and flip ramp are fully lowered when loading and unloading platform at ground level.

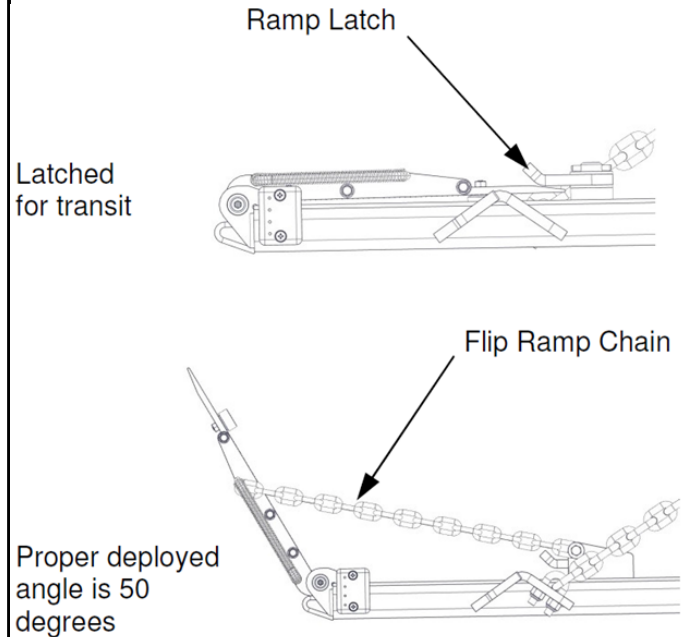

DUAL PUMP OPERATION INSTRUCTIONS

STANDARD ON WDV55 AND WDV66

The liftgate may be equipped with an optional Dual Pump Unit. The purpose of the Auxiliary Pump unit is to provide a backup in the event of a malfunction of the Primary Pump, Motor or Motor Solenoid.

The Auxiliary Pump is **NOT INTENDED FOR NORMAL OPERATION** of the liftgate. Liftgate must be repaired as soon as possible after a malfunction of the Primary Pump unit occurs.

TO OPERATE THE PRIMARY PUMP:

Move toggle switch on the pump to the "Primary Position".

Operate liftgate with controls on columns as usual.

TO OPERATE THE AUXILIARY PUMP:

Move toggle switch on the pump to the "Auxiliary Position".

Operate liftgate with controls on columns as usual.

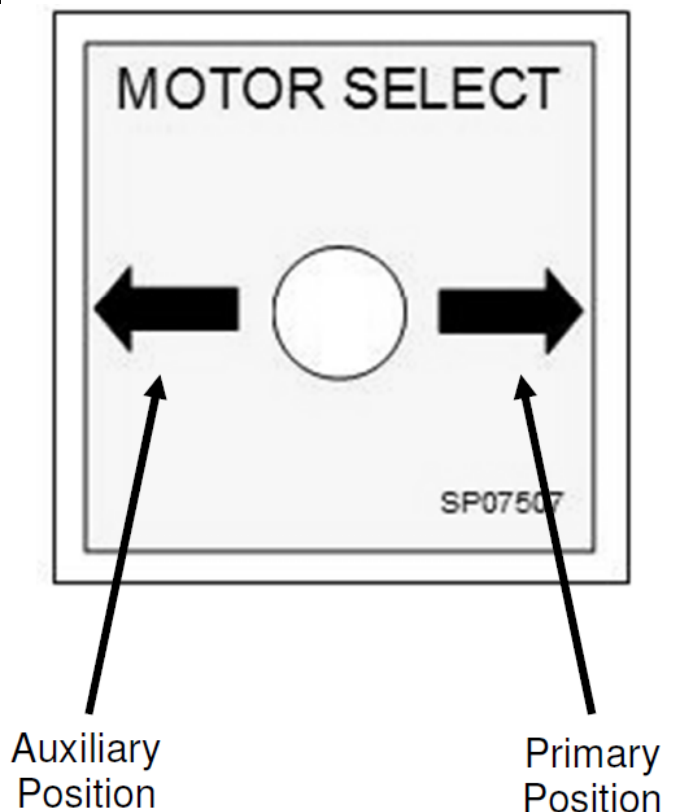

Chapter 3 Operation Instructions

WDVBG SERIES OPERATION INSTRUCTIONS

The WDV Direct Lift Bottle Gas liftgate (WDVBG) is a modified version of the standard WDV liftgate specifically designed for the handling of tall loads such as cylinder gas bottles. Use the instructions given below for the proper operation of the WDVBG Series liftgates.

The securing of tall, relatively unstable loads can be accomplished by using the chains as shown.

After placing a load in position as shown, fasten chain snugly around load to Chain Hook on Runner.

After use, chains are then hooked to the Guard Rail and the ramp is folded onto the platform skin as shown for transit.

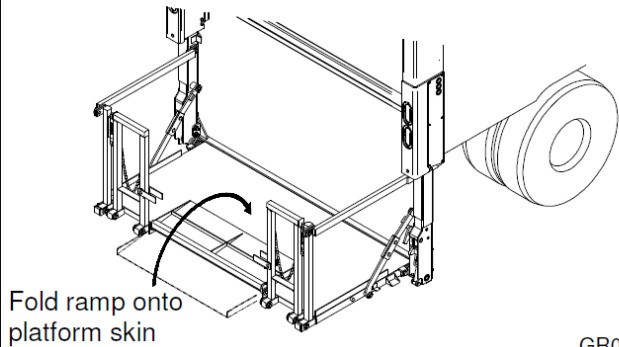
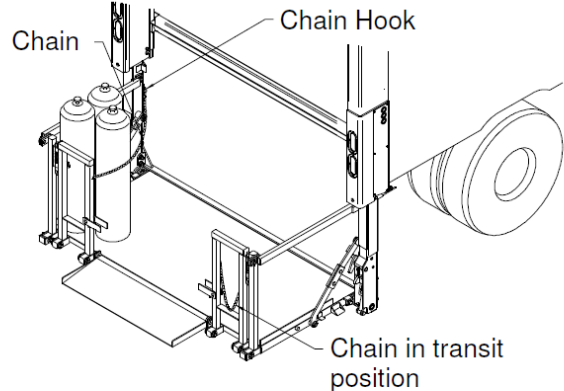

GR02371

WDVBG SERIES OPERATION INSTRUCTIONS

Another feature of the WDVBG is the Folding Ramp which may be used as a retaining device to prevent carts and similar devices from rolling off of the platform.

This is achieved by rotating the Latches located on the Guard Rails out of the way of the ramp between the Guard Rails as shown. Both Latches are then used to hold the Ramp in place.

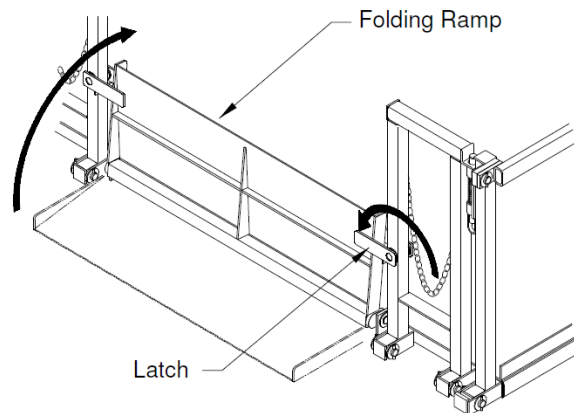

GR02372

Chapter 3 Operation Instructions

WDVBG SERIES OPERATION INSTRUCTIONS

If the vehicle is to be used for dock loading, the ramp is to be folded down onto the platform skin before raising the platform to the closed position (See Page 3-1 for closing platform instructions).

An additional feature of the WDVBG is that the Guard Rails can be folded down out of the way to increase the available opening width when dock loading as shown.

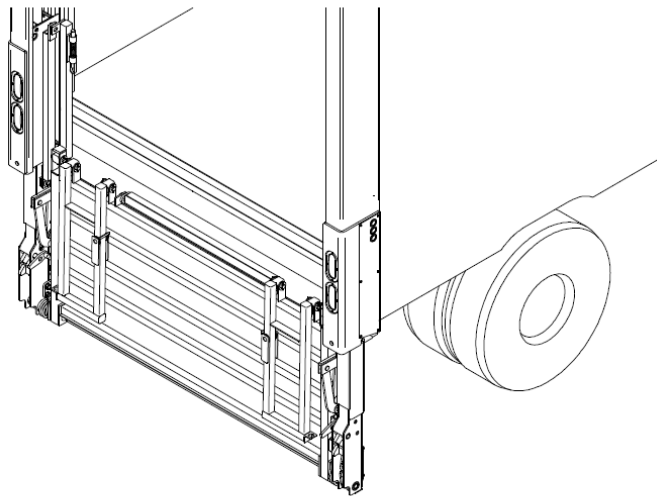

GR02373

Chapter 4 Preventative Maintenance

Waltco recommends that the WDV / WDVBG liftgate be inspected at 6 month or 3000 cycle intervals to help assure proper function and operation of the liftgate.

Note: Photocopy the following PM Checklist to help keep track of periodic maintenance on the liftgate. Keep completed form with maintenance records.

For more detailed instructions on the following checklist items, refer to the appropriate sections in this Owner's manual.



DO NOT CONTINUE TO USE LIFTGATE IF ANY POINTS OF INSPECTION LISTED AT LEFT, OR BELOW, MAY CAUSE YOU TO THINK THE LIFTGATE IS UNSAFE. REPAIR IMMEDIATELY.

If liftgate is found to be in need of repair or adjustment not covered in this manual, contact your nearest Waltco Distributor.

WALTCO PTN-SERIES LIFTGATE PREVENTATIVE MAINTENANCE CHECKLIST

PM Interval: 6 Months or 3000 Cycles Date: _____ Vehicle No. _____

Mechanic: _____ Liftgate S/N: _____ Model: _____

Circle appropriate box below for each step:

6 Month Liftgate PM Procedures

Inspect Liftgate columns:

1	OK	Repair Required	Corrected	Inspect for any physical damage, twisted, bend, spreading, broken welds, top and bottom.
2	OK	Repair Required	Corrected	Inspect for loose or missing bolts or pins.
3	OK	Repair Required	Corrected	Inspect that travel ear properly engages autolatch cam.

Inspect Liftgate dock bumpers:

4	OK	Repair Required	Corrected	Check for bent or broken steel bumper plates.
5	OK	Repair Required	Corrected	Inspect that dock bumpers are tight against columns and break away welds are intact.
6	OK	Repair Required	Corrected	Inspect for missing or damaged slide pad.

Inspect Liftgate platform:

7	OK	Repair Required	Corrected	Inspect for loose nuts, bolts and roll pins (Main hinge pin bolt, folding hinge bolt, roll stop and flip ramp bolts.)
8	OK	Repair Required	Corrected	ALUMINUM PLATFORM ONLY: Inspect that aluminum platform side plate bolts are tightened to 30 ft-lbs.
9	OK	Repair Required	Corrected	Inspect for any signs of overload damage, cracked or broken welds.
10	OK	Repair Required	Corrected	Inspect platform side chains, side chain hardware, side arm assembly, side attachment assembly for bent or missing parts.
11	OK	Repair Required	Corrected	Inspect that platform is level with the vehicle floor in the fully raised position.
12	OK	Repair Required	Corrected	Inspect folding hinges on platform and ramp for wearing. Platform should open flat with no dipping at center.
13	OK	Repair Required	Corrected	On liftgates with roll stops, inspect that roll stop opens when retainer is disengaged. Clean out roll stop hinge and lubricate with silicon spray.

Inspect Liftgate runner assembly:

14	OK	Repair Required	Corrected	Inspect for cracked or broken welds on hinge tube.
----	----	-----------------	-----------	--

Chapter 4 Preventative Maintenance

15	OK	Repair Required	Corrected	Inspect that pins are secure by making sure the pin retainers are in place and the retainer bolts are not loose or missing.
16	OK	Repair Required	Corrected	Inspect wear pads for wear and bracket for missing or broken bolts.
17	OK	Repair Required	Corrected	Inspect runner for physical damage.
Inspect Hydraulic and Electrical Components:				
18	OK	Repair Required	Corrected	Inspect for hydraulic leaks on cylinders, hoses and fittings
19	OK	Repair Required	Corrected	Inspect hoses for fraying or cracking (especially where hoses enter or exit the housing cover and hose extension cover).
20	OK	Repair Required	Corrected	Inspect that closing hoses are tracking properly and secured to liftgate column.
21	OK	Repair Required	Corrected	Remove power unit enclosure cover and inspect that electrical connections are clean and secure – spray connections with dielectric coating.
22	OK	Repair Required	Corrected	Inspect that fluid level in tank is 2" from the top with platform fully raised and open.
23	OK	Repair Required	Corrected	Inspect for any visible oil leaks inside the power unit enclosure. (valves, hoses, and fittings.)
24	OK	Repair Required	Corrected	Inspect power unit to make sure mounting is secure.
25	OK	Repair Required	Corrected	Inspect that master disconnects switch works properly and battery connection are secure. Spray terminals with dielectric coating.
26	OK	Repair Required	Corrected	Inspect circuit breaker for visual damage and ensure both motor and charge line circuit breakers are engaged. Spray terminals with dielectric coating.
27	OK	Repair Required	Corrected	Inspect that battery connections including grounds are secure and clean. Spray terminals and connections with dielectric coating.
28	OK	Repair Required	Corrected	Inspect entire length of battery cable (positive and ground) and exposed switch wires for chafing.
29	OK	Repair Required	Corrected	Load test batteries and perform battery maintenance as needed.
30	OK	Repair Required	Corrected	Inspect that battery hold downs are in place and properly tightened.
31	OK	Repair Required	Corrected	Inspect toggle switches for damage to 1/2 rubber boot.
32	OK	Repair Required	Corrected	Toggle to (optional) backup pump-motor and run liftgate through five complete up/down, open/close cycles to verify proper operation of backup system. Alarm should sound when running on backup motor.
Final Inspection:				
33	OK	Repair Required	Corrected	Run gate through two entire cycles with platform open to make sure there is no unusual noise.
34	OK	Repair Required	Corrected	Inspect that raising and lower speeds with empty platform are within 15-22 seconds (Based on a 50" bed height.)
35	OK	Repair Required	Corrected	Run gate through one cycle of the power open and close operation.
36	OK	Repair Required	Corrected	Inspect that opening and closing speeds are within 6-9 seconds.
37	OK	Repair Required	Corrected	Run gate up to stored position, make sure platform lock works properly.
38	OK	Repair Required	Corrected	Inspect that all decals are in legible and in the correct location.
39	OK	Repair Required	Corrected	Check operation of cycle counter
Annual Inspection/PM Procedure (Includes items 1-36 in Quarterly Inspection/PM procedure)				
40	OK	Repair Required	Corrected	Inspect platform hinge block/tube bushing (removal of platform required).
41	OK	Repair Required	Corrected	Change hydraulic fluid.

Chapter 4 Preventative Maintenance

Check that all bolts, fasteners and pins are tight and secure:

1. All Cylinder Pin bolts.
2. Lower Closer Cylinder Clevis bolt.
3. Linkage anchor bolts on platform and support chains.
4. Platform Hinge Pin Bolts.

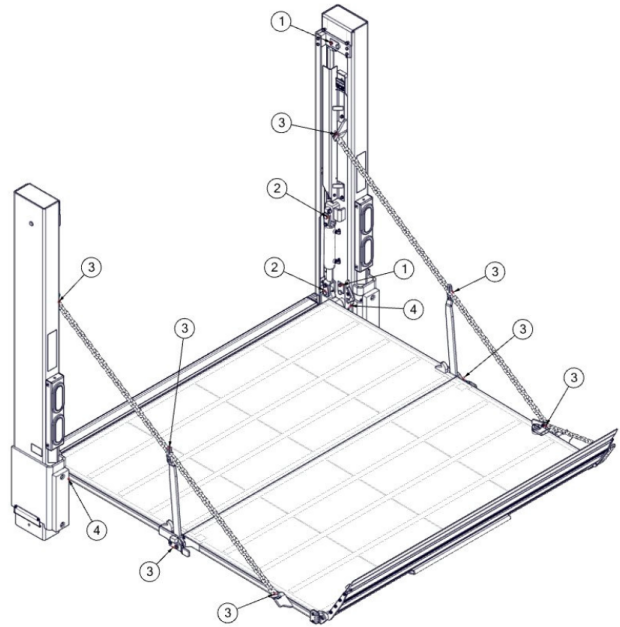

If liftgate has Aluminum Platform, check additional bolts, fasteners and pins are tight and secure:

1. All Platform Side Rail bolts (to have Torque of 30 ft-lbs).
2. All Ramp attachment bolts.

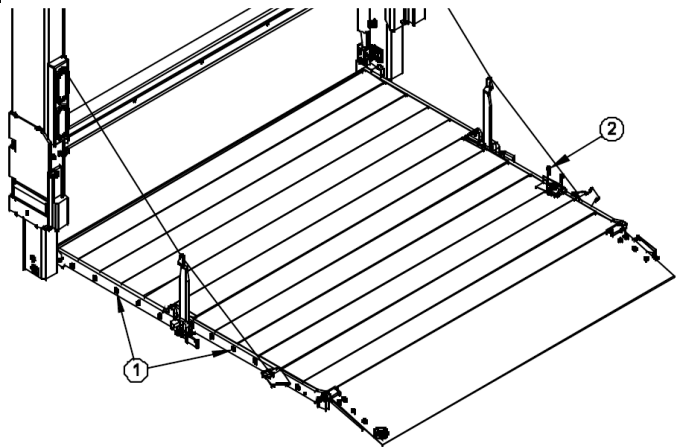

Chapter 4 Preventative Maintenance

If liftgate is WDVBG, check additional bolts, fasteners and pins are tight and secure:

1. Platform Ramp Hinge Pins and Hinge Plates.
2. All Guard Railing Pivot points.

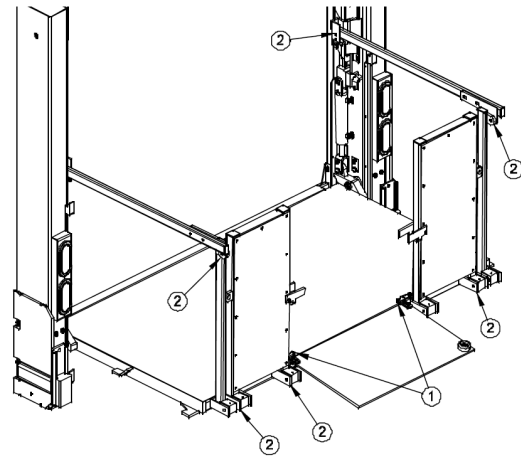

CHECK BATTERIES

Check electrolyte level of batteries.

Check that all wiring and battery cable connections are tight and free of corrosion.

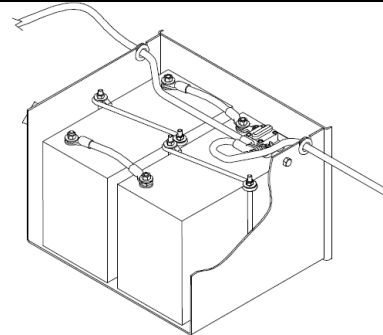

CHECK OIL LEVEL

For Liftgates with Gravity Down option:

Switch to Power Down mode using switch on pump box. Check oil level as per Power Down liftgate (as shown below).

For Power Down Liftgates:

Open platform and raise to to bed height. Check that hydraulic reservoir is filled to within 2" from the top.

NOTICE: Do **NOT** fill reservoir to top. Oil may overflow into pump box during operation.

WDV55, WDV66 & BACKUP PUMP-MOTOR OPTION

Toggle to backup pump-motor and run liftgate through five complete up/down, open/close cycles to verify proper operation of backup system. Alarm should sound when running on backup motor.

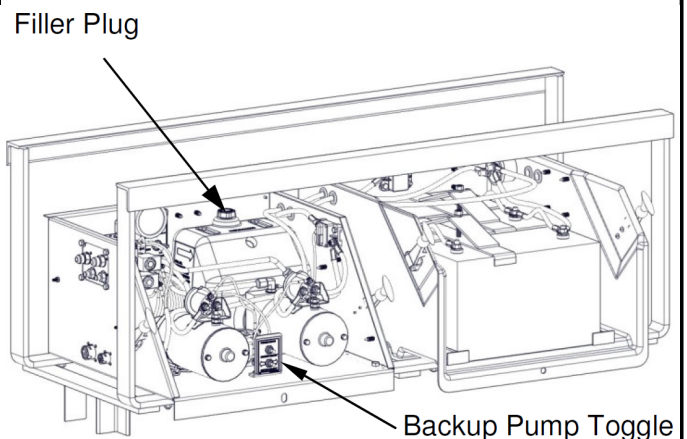

Chapter 4 Preventative Maintenance



Purchase in 1 gallon containers from Waltco
Parts Hotline 1-800-411-5685 www.waltco.com

Hydraulic Fluid Chart

Temp Range °F	Waltco Fluid Part #s and Acceptable Fluids
0 ⁰ to 120 ⁰	Waltco Biodegradable LiftLube Part # 85803860
	Shell Tellus S2 VX 32
	Chevron Rando HDZ 32
-20 ⁰ to 90 ⁰	Waltco Biodegradable LiftLube Arctic Part # 85803866
	Waltco All Season Hyd Oil Part # 85803867
	Shell Tellus S2 VX 15
	Mobil DTE 10 Excel 15
	Chevron Rando HDZ 15

7/16

80101494

Fill reservoir

- Fill with recommended fluid or equivalent.
- Fill the reservoir to within 2" from the top. (Oil level instructions above)

- Fluids are available from the Waltco Parts Dept. 1-800-411-5685 www.waltco.com

Note:

Do not use the following fluids:

- Brake Fluid
- Power Steering Fluid
- Automatic Transmission Fluid (ATF)
- Motor Oil

LUBRICATION INSTRUCTIONS

Please refer to Chapter 6 of the Manual for Lubrication Instructions.

ANNUAL INSPECTION

Perform procedures outlined in semi-annual inspection.

Inspect pump motor:

- Disconnect battery cables.
- Remove motor end cover.
- Clean residue from inside motor housing.
- Apply several drops of light weight machine oil to armature shaft bearing in motor end cover and reassemble motor end cover.

To replace Hydraulic Fluid:

- Open platform and lower to ground.
- Drain oil from hydraulic system using drain port located on bottom of reservoir and flush entire system.
- Fill reservoir to within 2" from the top. (Oil level filling instructions on previous page).
- Bleed hydraulics and top off reservoir as needed.
- Total system oil volume is approximately 16 quarts.

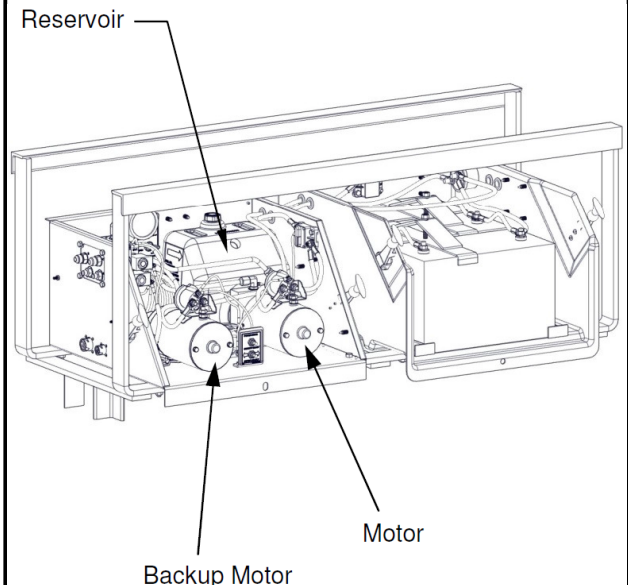

Chapter 5 Placement of Decals



All decals must be in place and legible or all warranties are void.

Properly placed warning decals are an essential part of your safety program. Check that all safety decals are in place and are legible. Any missing decals **MUST** be replaced immediately. Replacement decals may be obtained **FREE** of charge from your distributor or by contacting Waltco Part Sales:

Phone: (800) 411-5685, Email: parts@waltco.com



If your liftgate is equipped with dual controls, an additional Safety Instruction decal (80100850) is to be placed in a conspicuous place near the second set of controls.

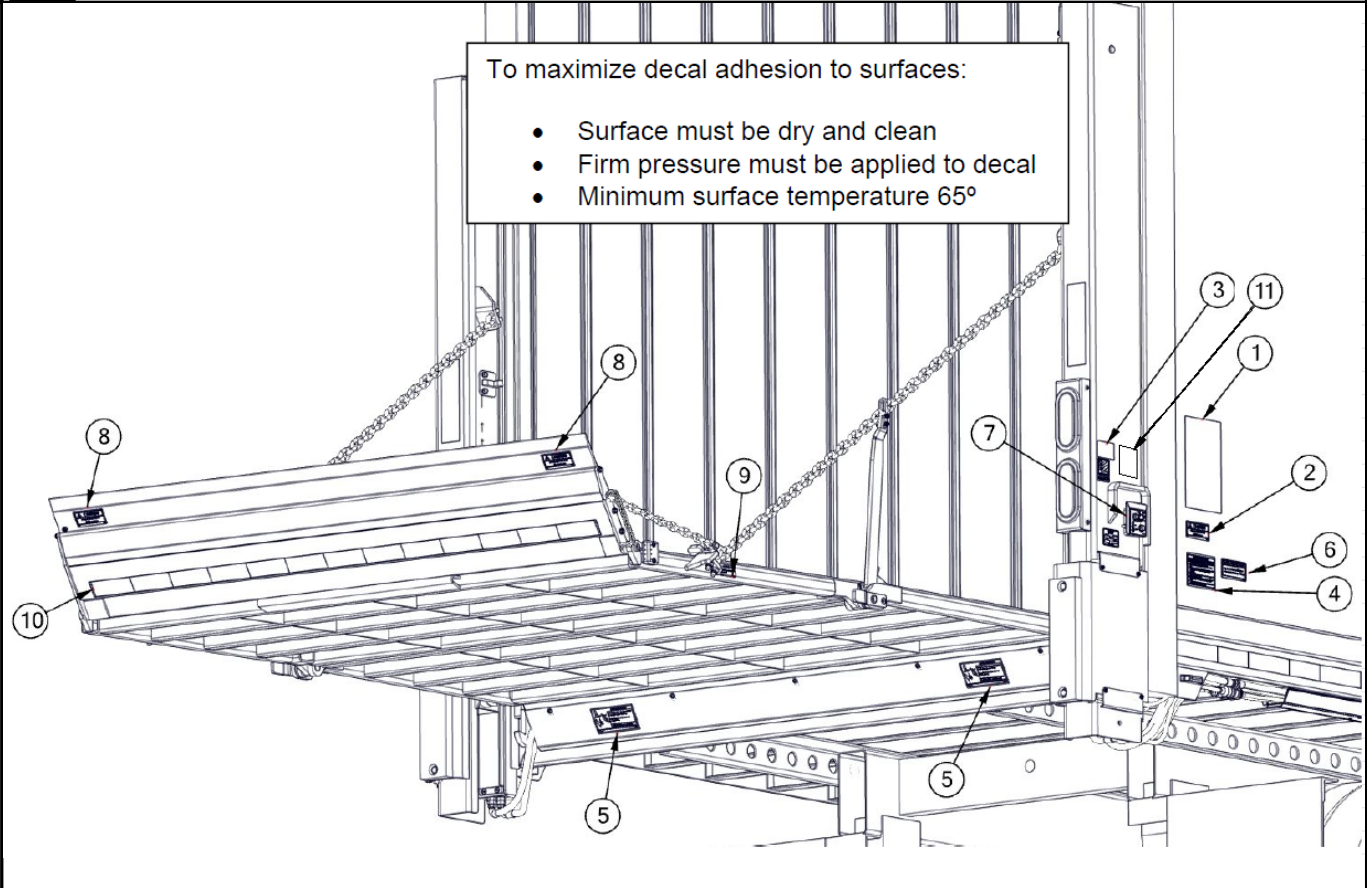

ITEM	DECAL	WDV35	WDV45	WDV55	WDV66	WDV w/ +16 FLIP RAMP	QTY
1	OPERATING INSTRUCTIONS			80101538			1
2	WARNING, KEEP CLEAR			75089296			2
3	WARNING, MAX CAPACITY	80100586	8010261	80101308	80101309		2
4	URGENT WARNING			80101308			1
5	DANGER, LIFTGATE CAN CRUSH			80101370			2
6	SAFETY, OPEN AND CLOSE			80101537			1
7	OPEN AND CLOSE DECAL			80101539			1
8	WARNING, KEEP CLEAR					75089296	2
9	FLIP RAMP STORAGE					80100482	1
10	CONSPICUITY TAPE FOR 96" WIDE WDV					82021067 (73.5")	1
	CONSPICUITY TAPE FOR 102" WIDE WDV					82021067 (78.5")	1
11	HICONNECT DECAL			80101003			1

Chapter 5 Placement of Decals

ALTERNATE PLACEMENT OF DECALS ON LIFTGATE ONLY



All decals must be in place and legible or all warranties are void.

Properly placed warning decals are an essential part of your safety program. Check that all safety decals are in place and are legible. Any missing decals **MUST** be replaced immediately. Replacement decals may be obtained **FREE** of charge from your distributor or by contacting Waltco Part Sales:

Phone: (800) 411-5685, Email: parts@waltco.com



If your liftgate is equipped with dual controls, an additional Safety Instruction decal (80100850) is to be placed in a conspicuous place near the second set of controls.

**IF DECALS MAY NOT BE PLACED ON VEHICLE,
PLACE THEM ON THE LIFTGATE AS SHOWN.**

To maximize decal adhesion to surfaces:

- Surface must be dry and clean
- Firm pressure must be applied to decal
- Minimum surface temperature 65°

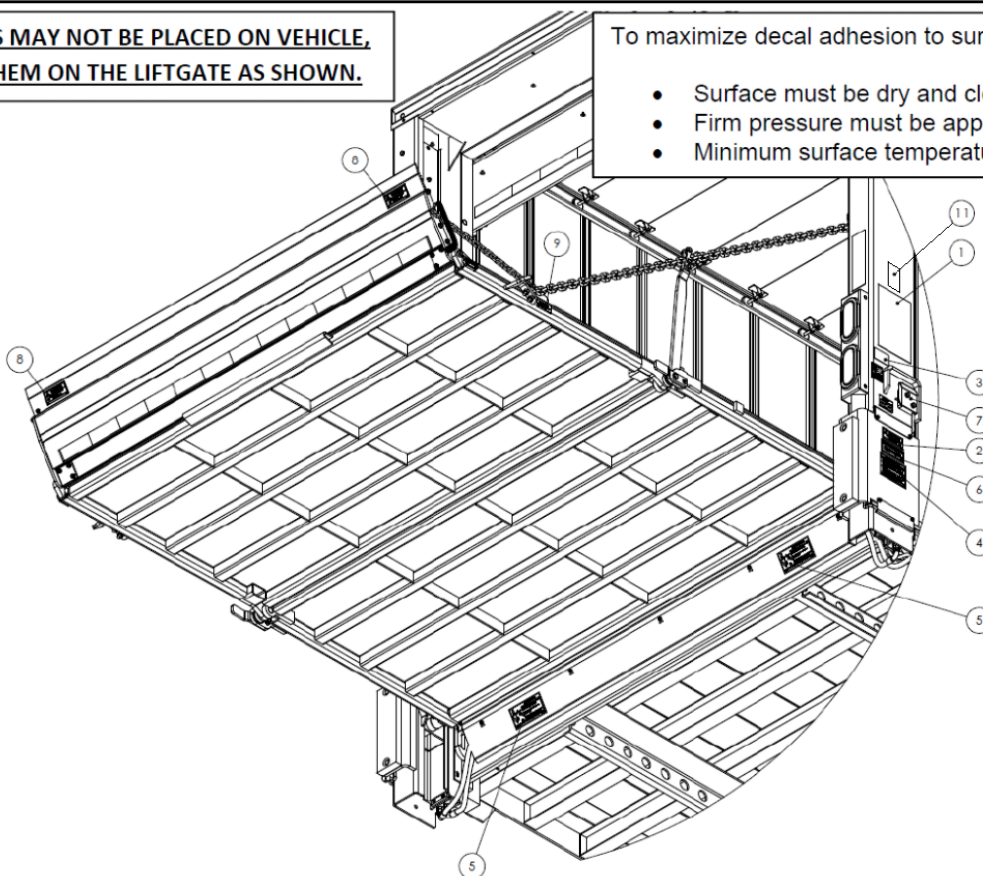

ITEM	DECAL	WDV35	WDV45	WDV55	WDV66	WDV w/ +16 FLIP RAMP	QTY
1	OPERATING INSTRUCTIONS			80101538			1
2	WARNING, KEEP CLEAR			75089296			2
3	WARNING, MAX CAPACITY	80100586	8010261	80101308	80101309		2
4	URGENT WARNING			80101308			1
5	DANGER, LIFTGATE CAN CRUSH			80101370			2
6	SAFETY, OPEN AND CLOSE			80101537			1
7	OPEN AND CLOSE DECAL			80101539			1
8	WARNING, KEEP CLEAR					75089296	2
9	FLIP RAMP STORAGE					80100482	1
10	CONSPICUITY TAPE FOR 96" WIDE WDV					82021067 (73.5")	1
	CONSPICUITY TAPE FOR 102" WIDE WDV					82021067 (78.5")	1
11	HICONNECT DECAL			80101003			1

Chapter 6 - Lubrication

LUBRICATION INSTRUCTIONS

The following areas ONLY should be lubricated approximately once a month, or as outlined in the lubrication scheduled for heavier usage. If not sure of duty or cycles, always lubricate more frequently.

(For all wear pads use a low viscosity lubricant such as machine oil or equivalent. For pins with grease fittings, use grease gun and appropriate high viscosity grease)

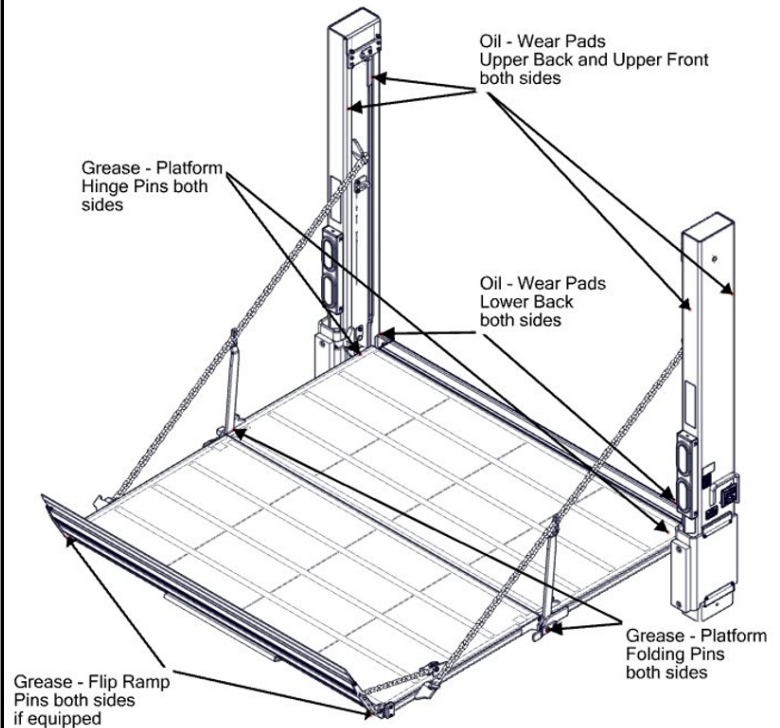

If the liftgate is a WDVBG, the additional points on the liftgate that require lubrication are the points indicated in the graphic to the right. These should be lubricated approximately once every three (3) months.

- Use a light weight machine oil to lubricate all Ramp and Guard Rail Pivot Pin areas as shown to the right.
- Grease Guard Rail Pivot Pins where zerk fittings

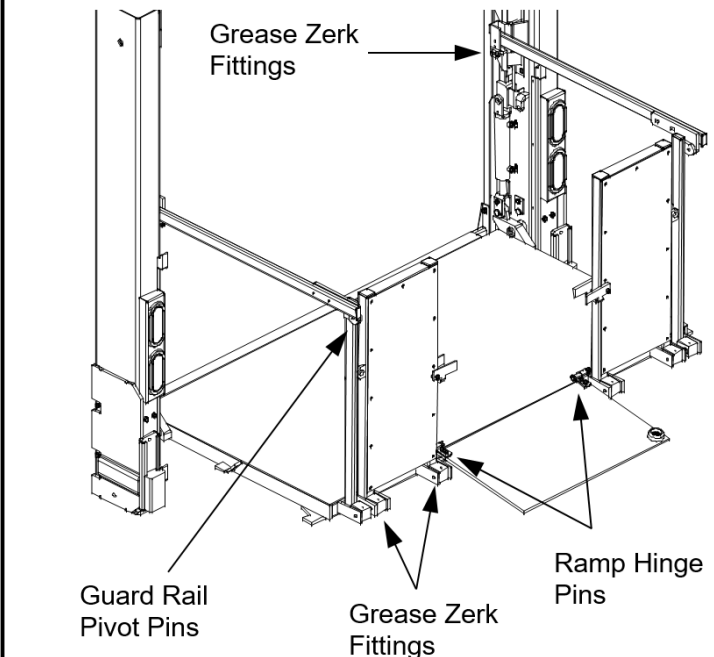

Chapter 7 PM's & Schematics

POWER UNIT HYDRAULIC/ELECTRICAL SCHEMATIC, SINGLE POWER UNIT - POWER DOWN

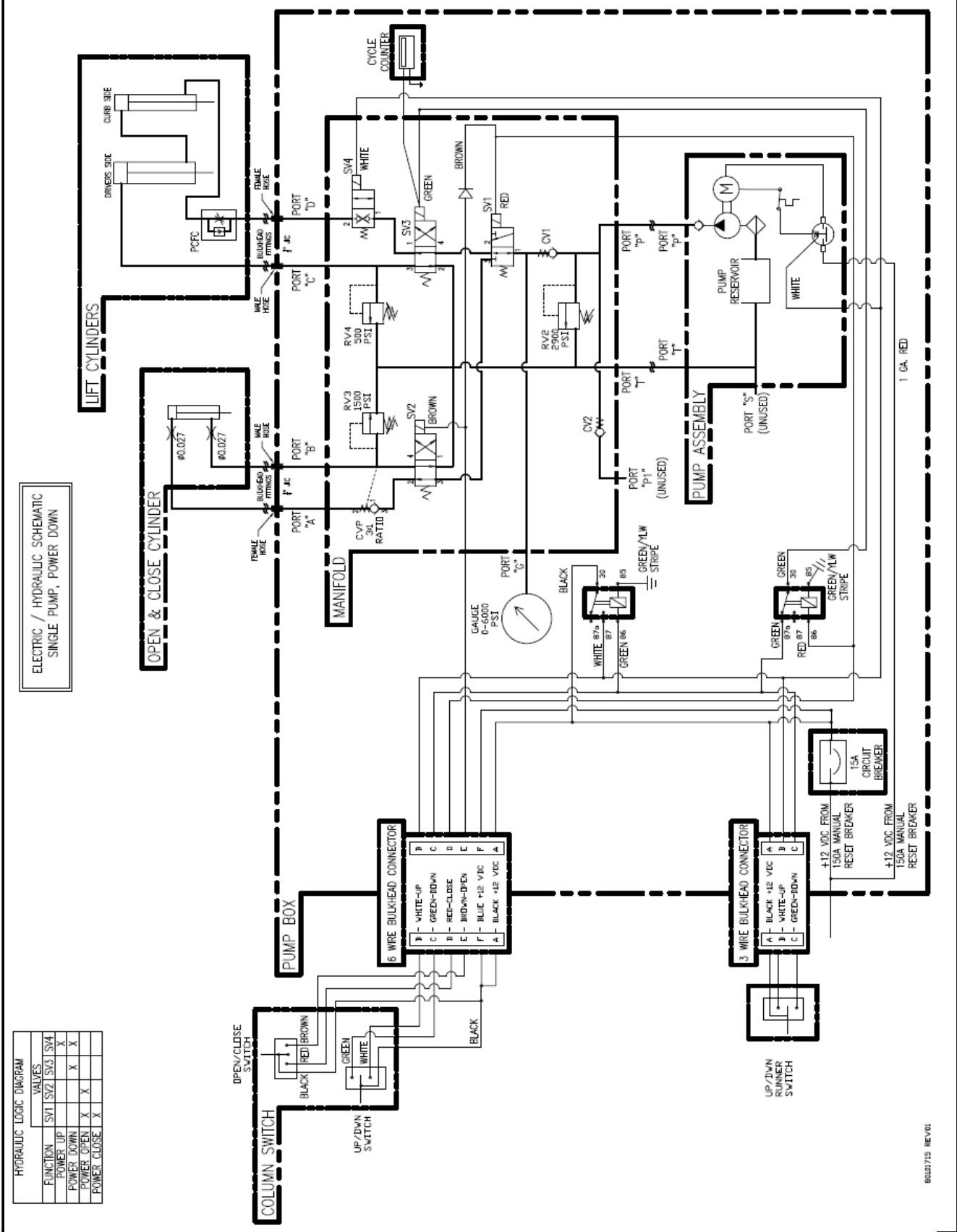

86J0715 REV01

Chapter 7 PM's & Schematics

POWER UNIT HYDRAULIC/ELECTRICAL SCHEMATIC, SINGLE POWER UNIT – GRAVITY DOWN ON DEMAND

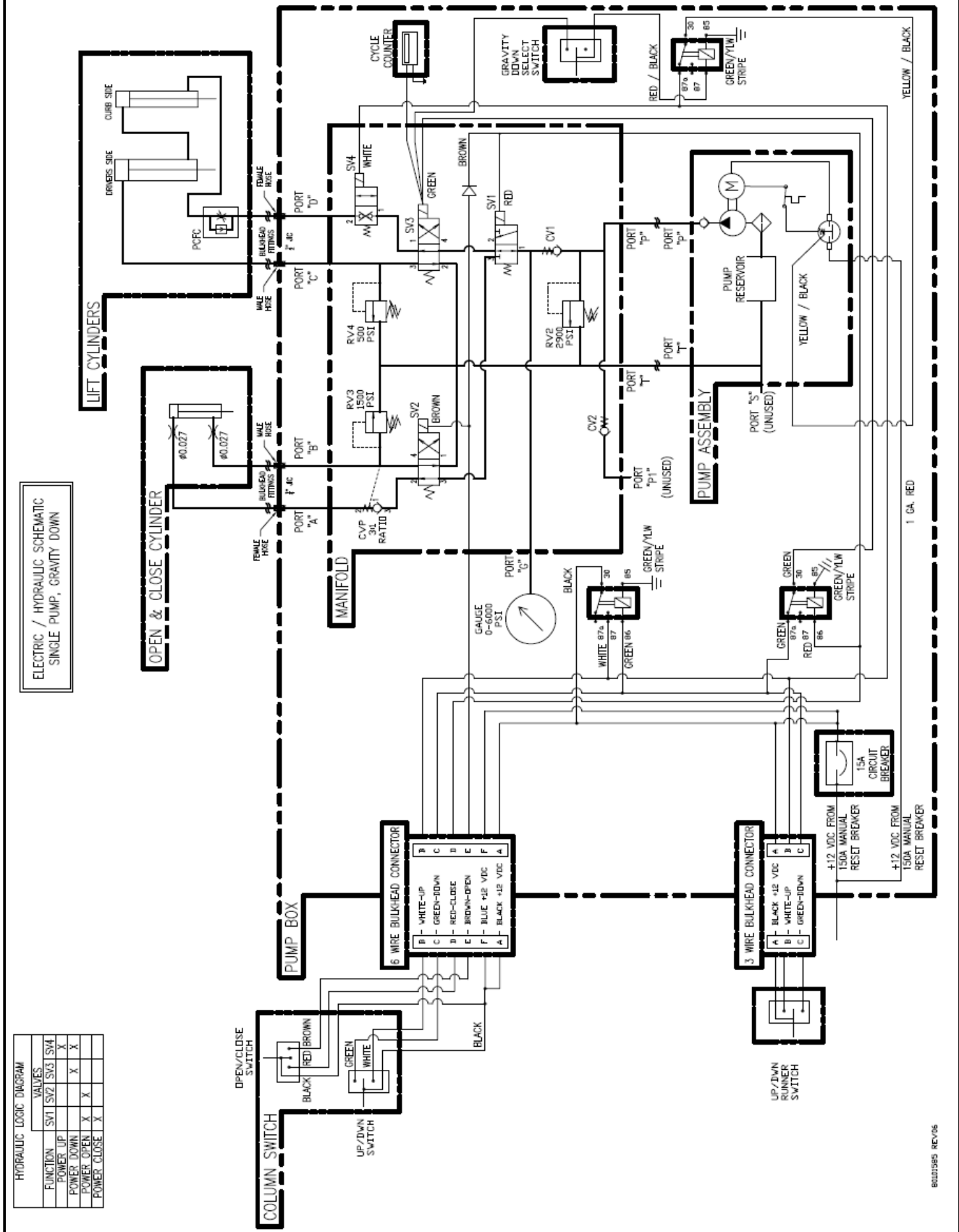

Chapter 7 PM's & Schematics

POWER UNIT HYDRAULIC/ELECTRICAL SCHEMATIC, DUAL PUMP MOTOR WITH BACKUP/AUXILLARY – POWER DOWN

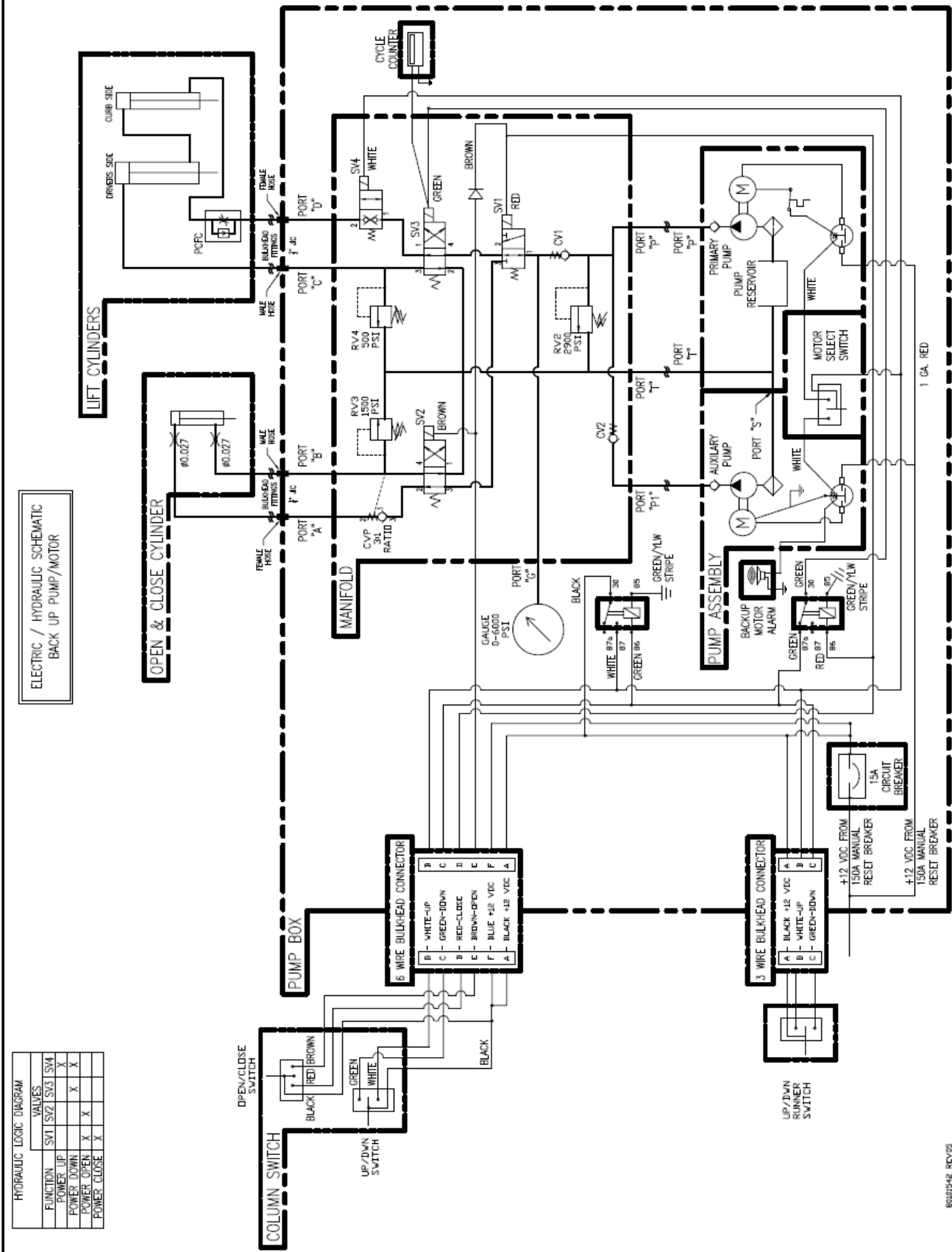

How To Order Parts

Repairs should be made only by authorized mechanic using WALTCO Replacement parts.

When ordering repair or replacement parts, please include all of the information asked for below. If this information is not available, a complete written description or sketch of the required part will help WALTCO identify and deliver the needed part to you.

THE FOLLOWING INFORMATION MUST BE INCLUDED:

- 1 SERIAL NUMBER - [WALTCO liftgate serial numbers can be found on the Specification tag attached to the mount frame. (On older units, the Specification Tag is located on the side or bottom of the platform)]
- 2 MODEL NUMBER - [Or capacity]
- 3 PLATFORM SIZE

THEN INCLUDE THE FOLLOWING INFORMATION:

- 4 PART NUMBERS
- 5 DESCRIPTION
- 6 QUANTITY REQUIRED

MAIL, E-MAIL OR PHONE YOUR REQUEST TO :

Waltco lift Corp.
1777 Miller Parkway
Streetsboro, OH 44241
1-800-411-5685
FAX: 1-800-411-5684
E-MAIL: parts@waltco.com

ALL PARTS ARE F.O.B. FROM THE SHIPPING FACTORY

PLEASE NOTE:

To assure you of continuing and effective quality control, our warranty policy permits replacement of hydraulic cylinders, valves and motor pump units when their factory seals are intact. Parts under warranty will be exchanged after careful inspection of the returned assemblies.

80101389

EO10758

REV 03

This page intentionally left blank.



Every vehicle that has a WALTCO liftgate must have legible **WARNING AND OPERATION DECALS** clearly posted on the vehicle and an **OWNER'S MANUAL** in the vehicle at all times as a guide for proper operation and maintenance.

Additional **WARNING DECALS**, **OPERATION DECALS** and **OWNER'S MANUALS** can be obtained from WALTCO LIFT CORP.

NOTE:

When ordering, give model
and serial number of the liftgate

IMPORTANT

KEEP THIS OWNER'S MANUAL IN THE VEHICLE



WARNING

Improper operation and maintenance of this liftgate could result in severe personal injury or death.

Read and understand the contents of this manual and all warning and operation decals before operating and/or performing maintenance on this liftgate.

**For SAFETY information on this liftgate see
Chapter 1 of this manual**