

# **MULTILIFT ULTIMA 21S COMMANDER**

## **CONTAINER HANDLING UNIT**



## Technical data

Type	MULTILIFT ULTIMA 21S COMMANDER	
Model	21S.56 CHU	21S.59 CHU
Vehicle type	3 or 4 axle	
GVW of the vehicle (t)	26-32	
Capacity hooklift (t)	21	
Capacity CHU (t)	16	
G-length	56	59
System weight (kg) (includes CHU components)	3750	3760
Tipping angle (°), flatrack	53	53
Max. operating pressure (MPa)	30	
Recommended oil flow (l/min)	100	

### Primary dimensions

LR = Body length (min - max) (m) internal	4,5 – 6,3	4,7 – 6,6
SL = Subframe length (mm)	6699	6969
B = Centre of gravity	3125	3235
G = Exact G-length*	5610	5880
HM = Horizontal movement, flatrack mode (mm)	950	1100
HM = Horizontal movement, container mode (mm)	1300	1450
TH = Hooklift tipping height (max) (mm)	5552	5767
LH = Hooklift loading/unloading height (max) (mm)	3380	4210
HP = Hook bar position (max) (mm)	3228	3330
BP = Body pickup height offset (HH 1570mm)**	-117	-123
h = Installation height (mm)	270***	
t = Min free tunnel height (body) (mm)	105***	
H = Hook height	1570	
BW = Body width	1070	

\* Exact G-Length can be +20mm/-40mm from dimension in the table depending on the hook height and body standard

\*\* Body pickup height offset is calculated from the final chassis height that the hooklift subframe is mounted to the truck.

Note! Any additional subframe added to the truck's chassis must also be calculated.

\*\*\* Installation height and corresponding free tunnel height depends on country and body standard

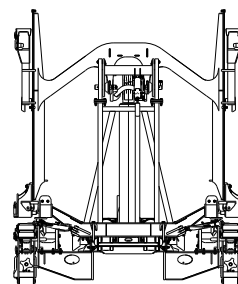
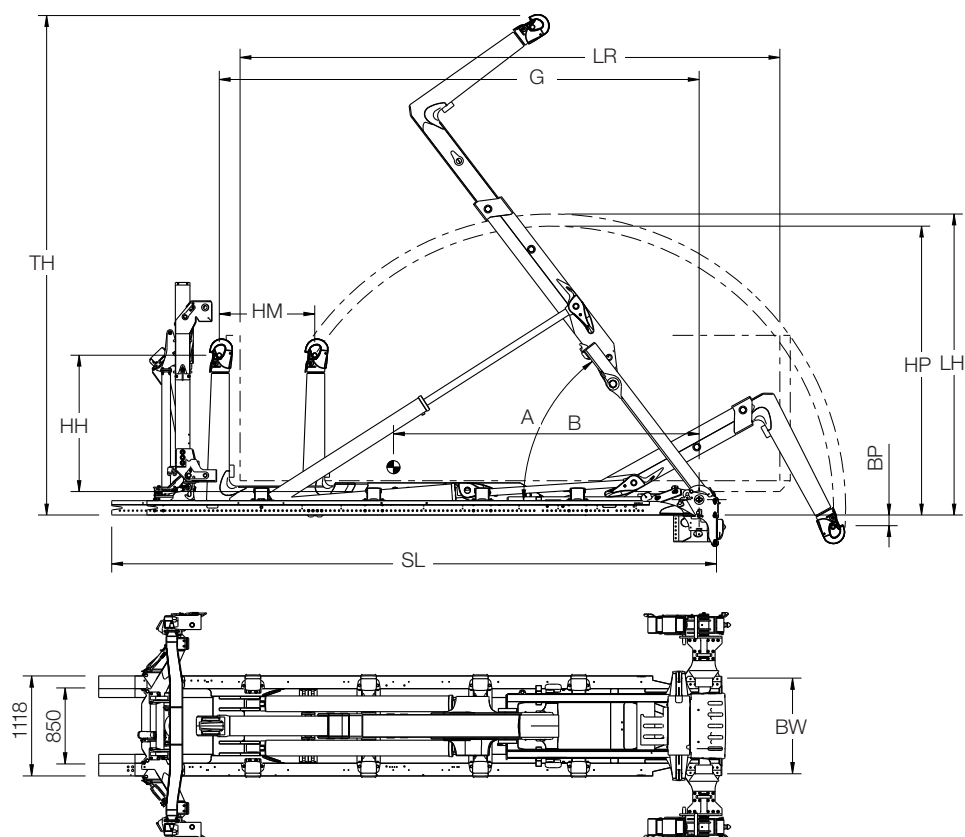

BD-MULTILIFTULTIMA21SCOMMANDER-EN-DIN\_190425



multilift.com

### Sales contact

Cargotec Finland Oy  
 Nesteentie 36, P.O.Box 39  
 FI-21201 Raisio, Finland  
 Phone +358 204 55 2399  
 hiab.com