

# Installation Manual

## BZ-33, BZ-44 Gen 7

3300 lb. & 4400 lb. Capacity Cantilever Liftgates

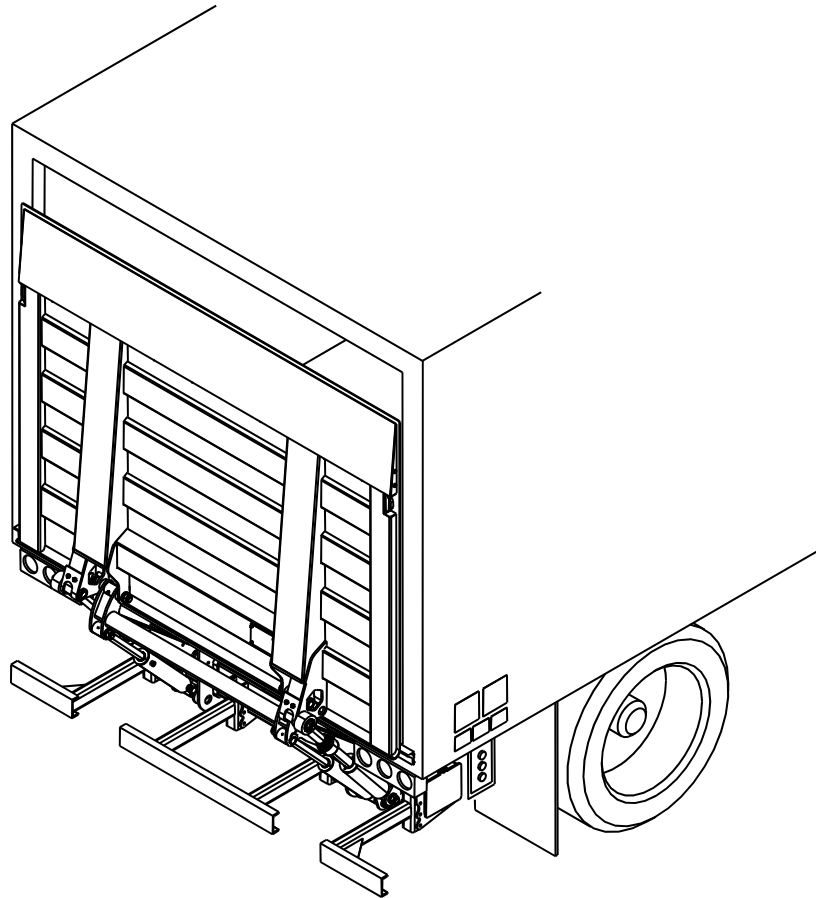

GR02912

### Last Change

Date	Pages	Description
08/2019	20-21	Added instructions for installing external sensor.

**Waltco Lift Corp.**  
**Corporate Office United State**  
285 Northeast Ave.  
Tallmadge, OH 44278  
P: 330.633.9191  
F: 330.633.1418

# Table of Contents



**Improper installation of this liftgate could result in severe personal injury or death.**

**Read and understand the contents of these instructions before proceeding.**

**When installed, this liftgate must not alter or prevent vehicle compliance to any existing state or federal standards.**

**Each chassis manufacturer's recommendations should be consulted for compliance.**

Introduction .....	3
Safety Information .....	4
Liftgate Terminology .....	6
Basic Mounting Requirements .....	8
Liftgate Installation .....	10
Electrical Installation .....	16
Electrical Schematics .....	17
Electrical Trouble Shooting .....	25
Battery Connection .....	33
Fill Reservoir .....	35
Platform Install .....	36
Up-Stop .....	39
Platform Tilt/Cylinder Adjustment .....	40
Bumper .....	44
Swing Door Applications .....	44
Check Operation .....	46
Placement of Decals .....	48
Lubrication Instructions .....	51
Final Inspection .....	52
 <u>Optional Kit Instructions:</u>	
Aux Battery Kit (Truck) .....	53
Kit #80001066	
Aux Battery Kit (Trailer)	
Kit #80001069	
Full Door Seal Kit .....	58
Kit #80000573	
Cycle Counter Kit .....	63
How to Order Parts .....	64

# INTRODUCTION

If anyone observes improper installation, improper operation, or damage, they should immediately contact a qualified person for assistance and correction. We strongly urge anyone that has any questions or doubts as to the installation, condition, use, operation, maintenance or repair of the liftgate to contact us at Waltco where we have qualified personnel that will be happy to assist you. Telephone numbers and addresses of these locations are listed in the Owner's Manual and Installation Instructions.

## INSTALLATION

Waltco liftgates should only be installed by those with sufficient basic skills to understand the installation and operation of the liftgate, along with the equipment on which the liftgate is being installed. Waltco's installation instructions are not intended to give rationale for all the instructions that are given; however, it is the intent of these instructions to give the installer both the operations and what we believe to be the most desirable sequence of implementing these operations. These instructions can in no way expand into an area where they will replace a qualified person, or clear thinking and a basic knowledge that must be possessed by the installer.

It has been our experience that a knowledgeable journeyman following these instructions and observing the operation of the liftgate will have a sufficient comprehension of the liftgate to enable this person to troubleshoot and correct all normal problems that may be encountered.

Failure to follow the installation instructions, adjustments and mounting dimensions may result in improper and unsafe operation of the liftgate. Unauthorized alterations of the liftgate can cause an undesirable and dangerous condition.

## OWNER'S MANUAL

The Waltco Owner's Manual is intended to act as a guide for operation and routine maintenance but is no way intended to encourage usage or repair of the liftgate by those who are not qualified to do so.

The contents of the owner's manual include, but are not limited to general operation instructions, routine lubrication, parts lists, and an outline of things that should be checked but may not be obvious to those not technically qualified. This manual assumes the liftgate is properly installed, undamaged and operates correctly. Improper installation, improper operation, or damage should be immediately corrected by a qualified person.

## INSPECTION

As part of the regular inspection of a liftgate and after damage or suspicion of an overload, inspect for wear or structural damage and make necessary repairs or replacements. Check all structural components and their attachment to the liftgate for cracked welds, loose fasteners, wear and part deformation. Check cylinder and hose for leaks. Inspections and repairs should be made by a qualified mechanic.

## REPLACEMENT PARTS

Use only Waltco original equipment replacement parts. Components of other liftgate manufacturers may outwardly appear to be the same but are not interchangeable with Waltco products. Waltco components are specifically designed for safety requirements, reliability and compatibility with our products. Refer to your Waltco parts manual when ordering parts. NOTE: When ordering, give model and serial number of liftgate.

## DECALS

It is important that every vehicle that has a WALTCO Liftgate have legible DECALS clearly posted on the vehicle and an OWNER'S MANUAL in the vehicle at all times as a guide for proper operation and maintenance.

Additional DECALS and OWNER'S MANUALS can be obtained from WALTCO LIFT CORP.

80101388 Rev 03 EO 7820

# Chapter 1 Safety Information

## WARNING

**Read, understand, and follow all of the warning listed below.**

**Failure to follow these warning could result in severe personal injury or death.**

- Read and understand the Owner's Manual, all decals and warning on liftgate before operating liftgate.
- Do not operate liftgate without a thorough knowledge and understanding of the operation of the liftgate.
- Liftgate hazards can result in crushing or falling.
- This liftgate is designed for loading and unloading of cargo. If personnel are required to ride liftgate, observe and familiarize yourself with the liftgate operation, decals and manuals. Ensure stable footing at all times.
- Do not ride liftgate with unstable loads.
- Wheeled loads must be properly retained from rolling.
- Tall, high center of gravity loads must be retained from falling over.
- Never overload liftgate:  
Load platform as close to the vehicle, and towards the middle of the platform as possible. Refer to owner's manual and capacity decal of liftgate for maximum load and load placement.
- Keep hands and feet clear of all potential pinch points.
- Never use liftgate if it makes any unusual noise, has unusual vibration, raises or lowers unevenly, or fails to operate smoothly.
- Never use liftgate if it shows any signs of structural damage such as cracked welds, bent or distorted members.
- Do not attempt any repairs unless you are qualified to do so. Care should be taken when work is performed on a disabled liftgate located near moving traffic. When possible the vehicle should be moved away from traffic areas for repair. Precautionary measures should be taken to ensure personal safety including those recommended in Federal Motor Vehicle Safety Standards 571.125.
- When welding to liftgate, or liftgate components, take all necessary safety precautions, including using respiratory protection and other pertinent personal protective gear when welding harmful materials.
- All protective covers, guards, and safety devices must be in place and access doors closed before operating liftgate.
- Do not allow anyone to stand in, or near area, in which Platform will open and close before opening or closing Platform.
- Do not allow anyone to stand near the Platform where a falling load could land on them.
- Platform is always to be properly stored and secured for transit. See the Owner's Manual for details.
- Take care to retain cargo during transit for liftgate Platforms which function as the tailgate or door of the cargo area. Small objects can fall through the space between the vehicle and the folded Platform.
- A Lock-Out device or Shut-Off Switch should always be used to prevent unauthorized use of liftgate.
- For liftgates with Runners, never use liftgate if Runners do not travel freely and smoothly.
- For liftgates with Roller Lifting Chain, the Chain should be replaced every (5) five years or 15,000 cycles, whichever comes first. Replace only with Waltco approved Roller Chain.
- Never transfer loads which exceed lifting capacity on or over any part of the Platform unless the liftgate is equipped with a special reinforced Platform and Platform Support Bars for use when the Platform is used as loading ramp (dock board). Refer to the "Using Platform as a loading ramp" Chapter in the Operation Instructions of the BZ/RZ series Owner's Manual.
- For liftgates equipped with Trailer Hitches, never exceed the rated capacity of the hitch. Do not exceed the vehicle's weight rating. Refer to the vehicle's Owner's Manual.
- Vehicle must comply with all state and federal standards.
- Follow the "Maintenance Guide" chapter in the Owner's Manual.

# Chapter 1 Safety Information

## Liftgates with Tilt Function

- Proper use of the Control Switches is of extreme importance.
- Improper use of Tilt Switch could cause load to fall from the Platform or damage the liftgate.
- Platform should be in a generally horizontal position when raising or lowering with a load.
- In any tilt position, the Platform may vary from level while raising or lowering the Platform.

## Liftgates equipped with spring operated Cam Closer

- Replace Cam Release Spring every five (5) years or 15,000 cycles, whichever comes first.

## RGL-Series Liftgates

- Make certain Platform Brake mechanisms are operating properly.
- The Runners are always to remain powered up against the Upstops Pins when in transit.
- Inspect Cables every three (3) months or 750 cycles, whichever comes first. Cables must be replaced if they show signs of wear, distortion, kinking or if any broken wires are visible
- Replace cables every five (5) years or 10,000 cycles, whichever comes first.



This is the safety alert symbol. This manual uses this symbol to alert you to potential personal injury hazards.

Obey all safety messages that follow this symbol to avoid personal injury or death.

## SIGNAL WORDS

### WARNING

Indicates a potentially hazardous situation, which if not avoided, could result in death or serious injury.

Black letters on an orange background

### CAUTION

Indicates a potentially hazardous situation, which if not avoided, may result in minor or moderate injury. May also be used to alert against unsafe practices.

Black letters on a yellow background.

### NOTICE

Indicates a potentially hazardous situation, which if not avoided, may result in property damage.



# Chapter 2 Liftgate Terminology

1. Platform
2. Mount Tube
3. Pump and Motor Tray
4. Lift Arm
5. Bumper
6. Lift Cylinder
7. Tilt Cylinder
8. Upper Lift Arm Pin
9. Lower Lift Arm Pin
10. Upper Lift Cylinder Pin
11. Lower Lift Cylinder Pin
12. Upper Tilt Cylinder Pin
13. Lower Tilt Cylinder Pin
14. Marker Lights
15. Sill Extension
16. Mount Plates
17. Cart stop (optional)

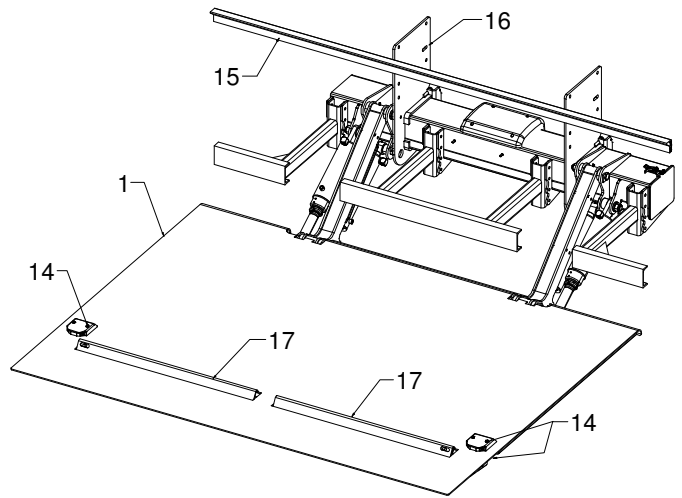

GR00828

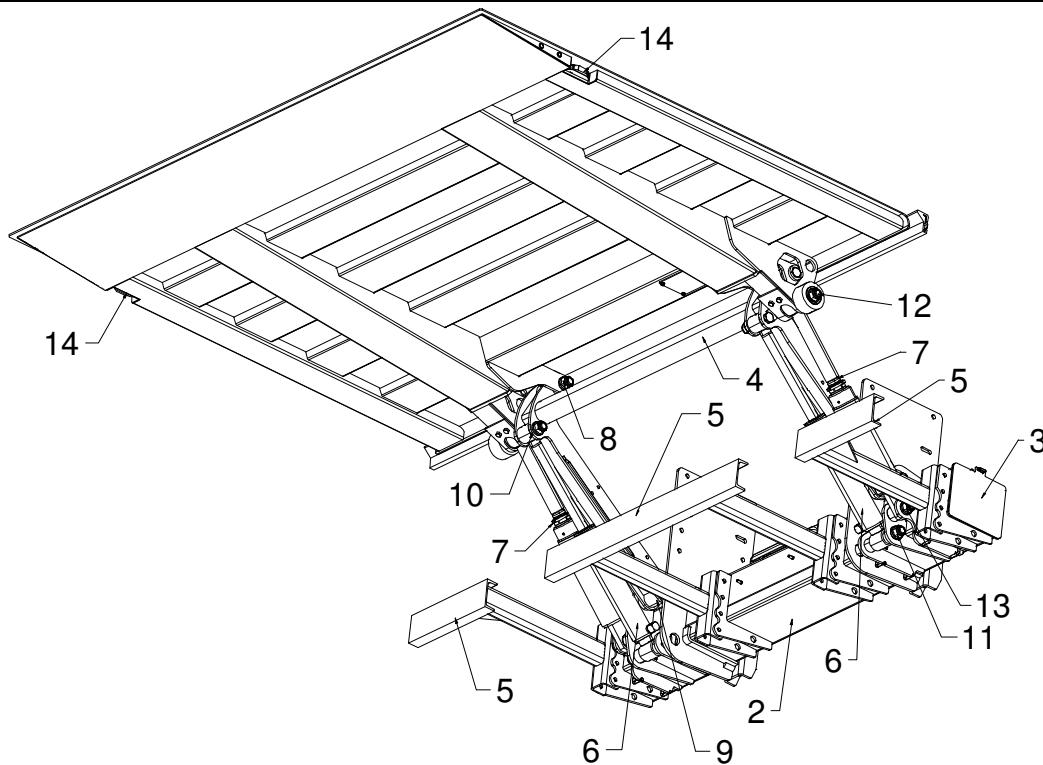

GR00829

# Chapter 2 Liftgate Terminology

## Explanation of Specification Tag

BZ33 G7	Level Lift	3300 lbs.
BZ44 G7	Level Lift	4400 lbs.

**MODEL NUMBER**

**RATED CAPACITY**  
Based on an evenly distributed load on the platform flat surface.

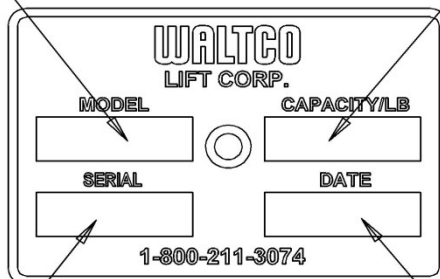

**SERIAL NUMBER**  
of liftgate. To be used when ordering parts or when contacting Waltco for service or warranty questions

**DATE OF MANUFACTURE**  
Month / Year

GR00241

## LOCATION OF SPECIFICATION TAG

Can be found on driver's side, end of mount tube.

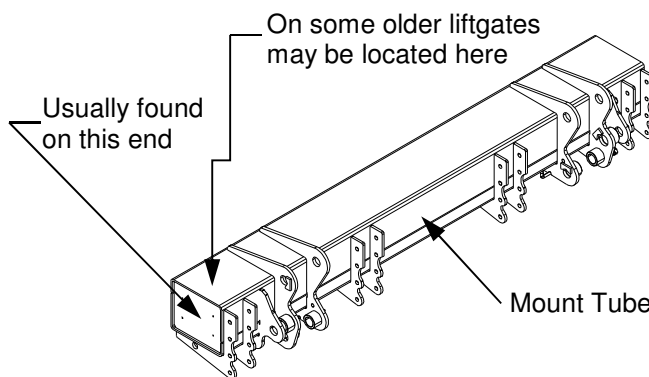

GR02226

# Chapter 3 Basic Mounting Requirements

## MOUNTING DIMENSIONS

Determine bed height. Measure from top of vehicle floor down to ground.

**NOTE:** All dimensions when vehicle unloaded on horizontal surface.

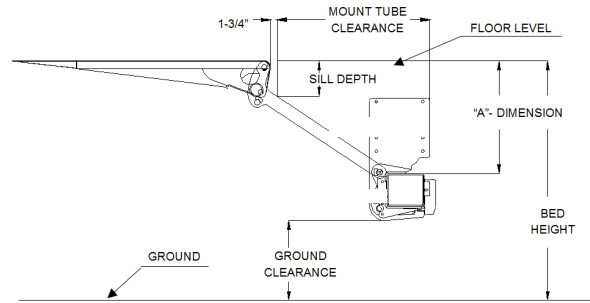

GR00494

## CALCULATING MINIMUM A DIMENSION:

The A dimension is the distance from the top of the floor to the top of the lift gate mount tube.

The mount tube must be installed at least 1-5/8" below vehicle chassis to allow room for mounting brackets.

The minimum A dimension allowable is the distance from the top of the floor to the bottom of the vehicle chassis plus 1-5/8".

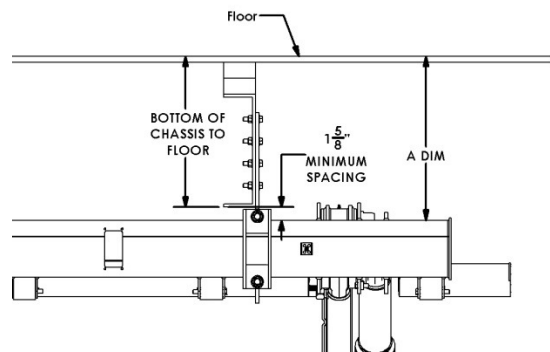

GR00496

## FRAME WIDTH

Liftgates can be mounted to trucks and trailers with max frame width 45- 1/2".

Additional mounting configurations and dimensions may be available by contacting the Waltco Engineering Department.

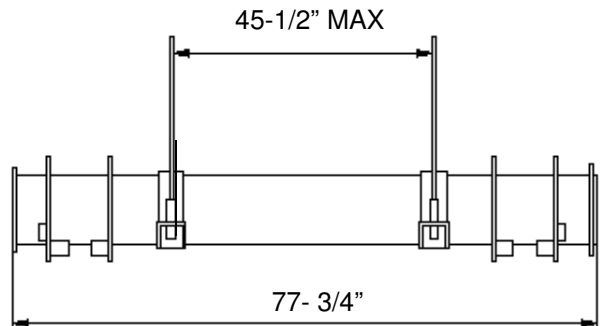

GR00655

## MOUNTING BRACKETS

Mounting brackets height may need to be trimmed in order to achieve desired A- dimension. After modification a minimum of 6 of the outer holes must remain available for use.

**IMPORTANT!** Do not modify mounting bracket bolts, nuts or mounting surfaces that are in contact with mount tube.

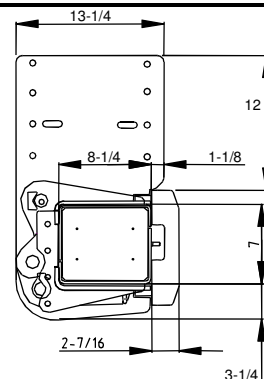

GR02987



# Chapter 3 Basic Mounting Requirements

## DETERMINING INSTALLATION DIMENSIONS

To determine the installation dimensions:

1. Determine the smallest A dimension your vehicle allows. (Distance from top of floor to bottom of chassis plus 1-5/8")
2. Using the table below that corresponds to your gate's arm length, verify that your vehicle is compatible with the max sill depth, mount tube clearance and max unladen bed height for that A dimension.
3. If necessary, increase the A dimension until the corresponding max sill depth, mount tube clearance and max unladen bed height for that A dimension are compatible with your vehicle.
4. Very acceptable ground clearance:  $\text{Ground Clearance} = \text{Bed Height} - \text{A Dim} - 10.25''$   
NOTE: Minimum allowable bed height is dependent solely on the required ground clearance.

Additional mounting configurations and dimensions may be available by contacting the Waltco Engineering Department.

**Important!** Do not exceed the maximum listed bed height for the A dimension used. This can cause damage to the liftgate and improper proper operation of the liftgate.

### BZ-33/44 Short arm, 29-1/2" Optional

A-Dimension	Maximum sill depth	Mount tube clearance	Max Unladen Bed Height
15.5	4	33	43
18	5	31.5	45
20	5.5	30	47
21.75	6.5	28.5	49
23.75	7	26.25	51
25.5	7.75	24.5	52.5

### BZ-33/44 Long arm, 34-1/4" Standard

A-Dimension	Maximum sill depth	Mount tube clearance	Max unloaded Bed Height
18.25	5	36.75	49
20.25	5.5	35.5	51
22.25	6.5	34.25	53
24.25	7	32.5	55
26.25	7.5	30.75	57
28	8.25	28.5	59
29.5	9	26.75	60

# Chapter 4 Liftgate Installation

## PREPARATION OF BODY

Remove all obstructions that will interfere with liftgate operation.

Dock bumpers

Trailer hitches

Other projections

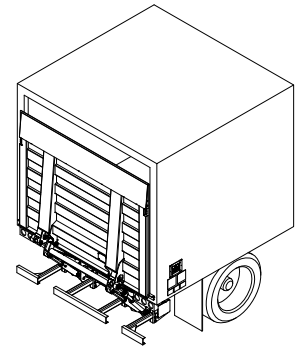

GR00511

## NOTCH REAR SILL

Mark a witness line at center of rear sill. This line will be used for centering the liftgate later.

If rear sill is deeper than the "Max Sill Depth", as indicated in the Mounting Requirements, notch as shown.

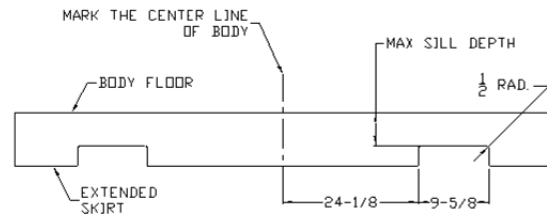

GR00497

## REINFORCE SILL NOTCH

Use 3/16" or 1/4" x 2" steel bar.

Form bar and weld in place.

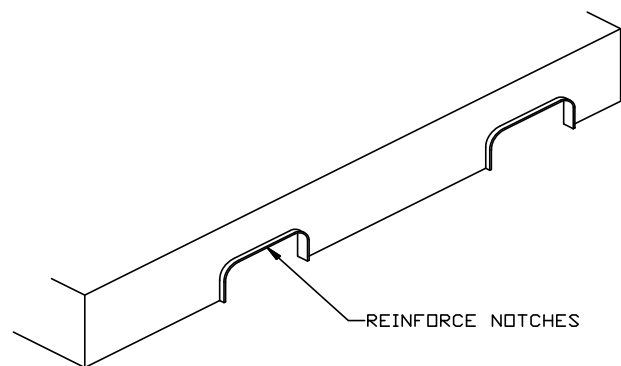

GR00056

# Chapter 4 Liftgate Installation

## REINFORCE REAR SILL AREA

If necessary extend chassis frame back to rear sill.  
 Add bar or angle to cap off frame and tie it in with rear sill.  
 Add a tie strap on the side of the chassis frame to tie it together with the body long member.

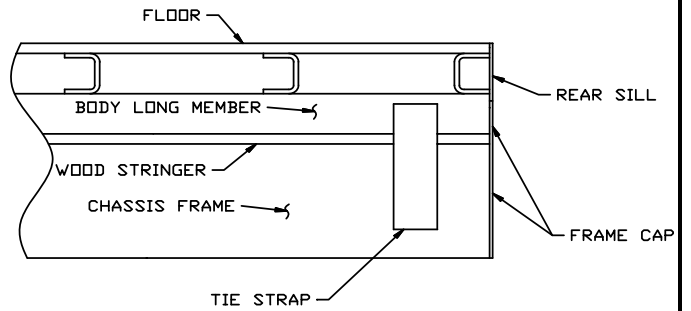

GR00057

## CONSTRUCT MOUNTING JIG

Cut a length of 3" angle, or similar material, approx. 70" long.

Make two (2) plates with 1-3/16" dia. holes as shown.

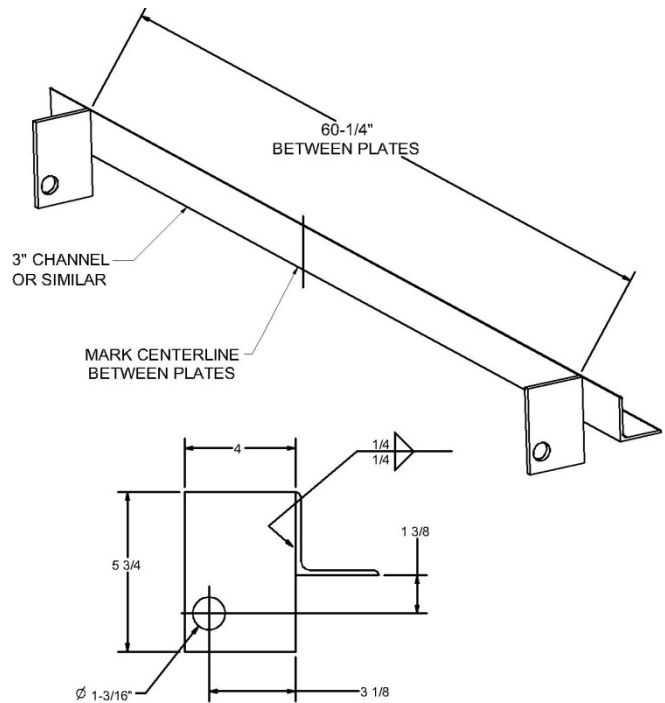

GR00498

# Chapter 4 Liftgate Installation

Locate and tack-weld the mounting jig to rear sill of body.

Align the centerline marks of the jig with mark on sill.

Verify the 1-3/8" and 3-1/8" dimensions.

**Note:** For vehicles with swing doors, refer to section in back of manual "For Vehicles with Swing Doors".

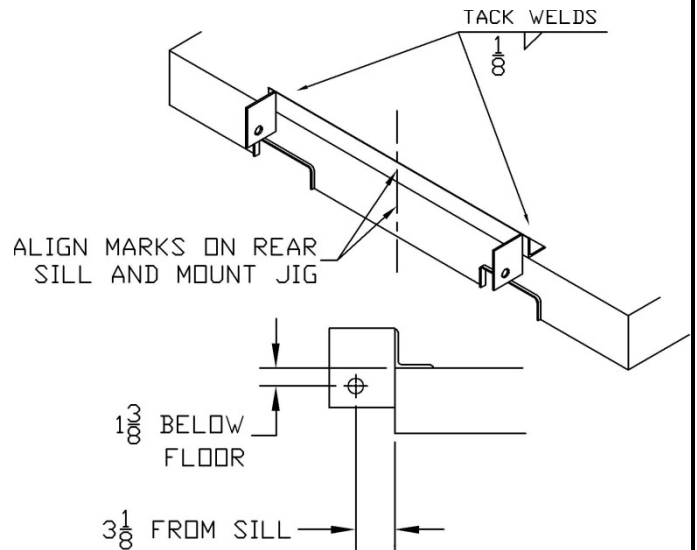

GR00499

## MOUNT LIFTGATE TO MOUNTING JIG

Disconnect all four (4) cylinders from the lift arms.

Remove the temporary shipping pins from the tilt cylinders and lift arms.

Remove the lock nuts and pins from the lift cylinders and lift arms.

**Note:** The outer two cylinders are the tilt cylinders.

Do not remove any pins from mount frame.

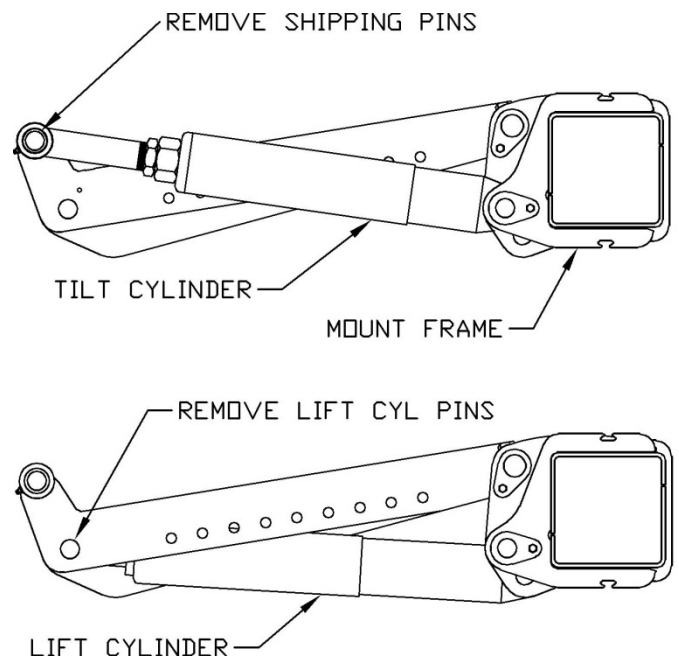

GR00060

# Chapter 4 Liftgate Installation

Check that lift arm assembly pivots freely on pivot pins in mount frame.

If necessary, loosen nuts on pivot pins indicated.

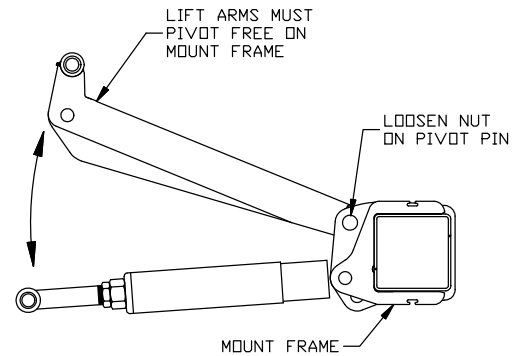

GR00061

Position liftgate mount frame on a floor jack or other type of lifting device.

Rotate lift arms up to the mounting jig.

Temporarily secure lift arms to mounting jig with long bolts and nuts supplied with liftgate or platform.

**Other means may be used to support Mount Frame in position. ALWAYS verify the safety of your supporting method before proceeding.**

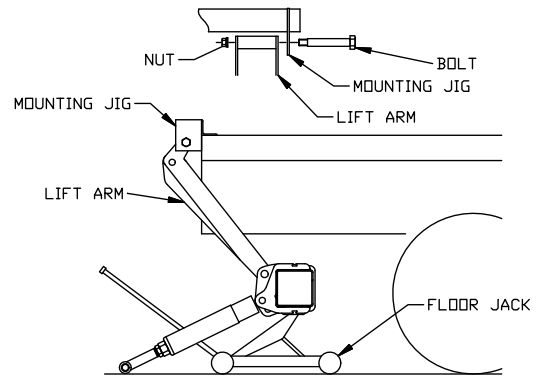

GR00062

# Chapter 4 Liftgate Installation

Jack mount frame up to the proper "A" Dimension.  
Refer to the Mounting Requirements in this manual.

**Note:** Use the smallest "A" Dimension per the chart, this insures the greatest ground clearance.

**Important:** Top of mount tube is not to contact the vehicle chassis frame.

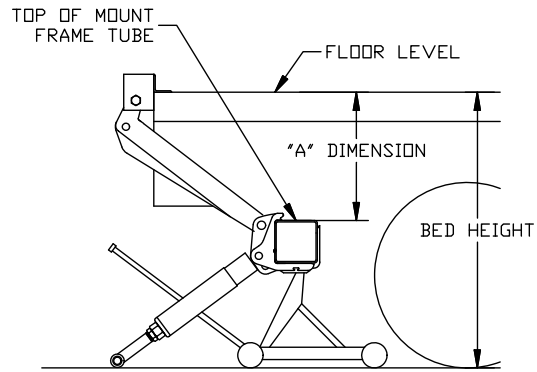

GR00063

Position mount plates over mount tube, and up against vehicle chassis frame.

Open end of mount plates must face front of vehicle.

Rotate liftgate and mount plate so plate is 90° degrees to chassis frame.

Drill 1/2" holes, centered in slots, through chassis frame.

**Note:** In some installations it may be necessary to trim off top of mount plates to clear body cross members. After modification a minimum of 6 of the outer holes must remain available for use.

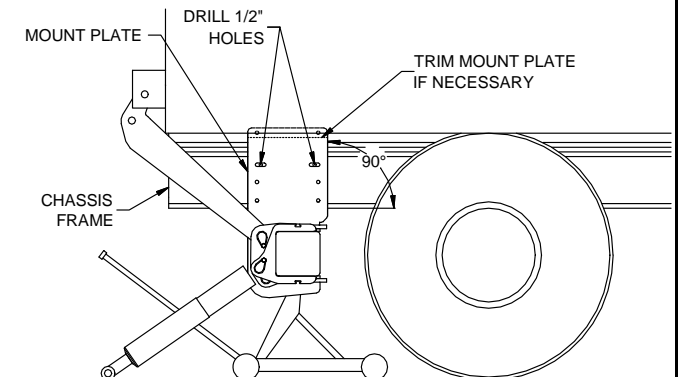

GR00064

# Chapter 4 Liftgate Installation

Bolt mount plates to chassis frame and install endplates onto mount plates.

Using 1/2" bolts and square washers, bolt mount plates to vehicle chassis frame.

Install endplates as shown with provided nuts and washers and torque to 85 ft. lbs.

**Note:** Do not install any more bolts or weld mount plates to chassis frame at this time.

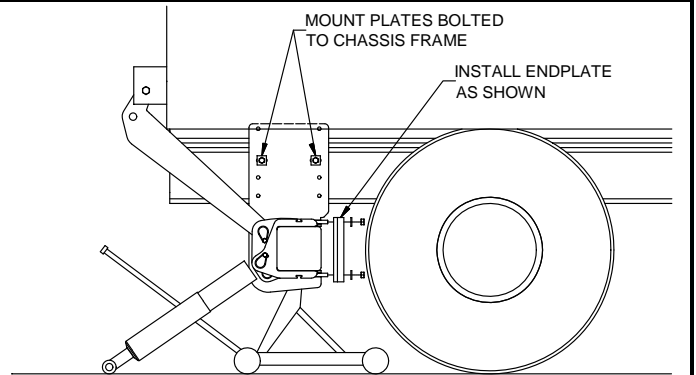

GR00065

Re-attach lift cylinders to lift arms.

Unbolt lift arms from mounting jig, and lower arms to ground.

Reinstall lift cylinder pins and locking nuts.

Remove mounting jig from rear sill.

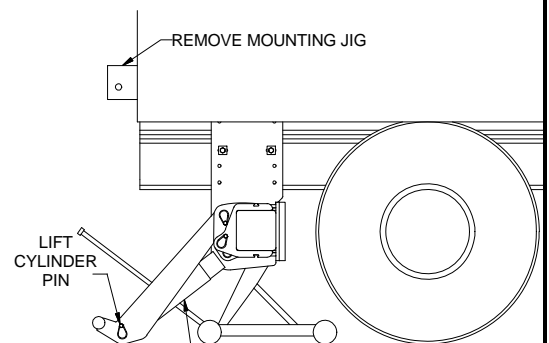

GR00066

# Chapter 4 Liftgate Installation

Install control units at suitable places, but the position of the control unit should ensure that the operator has a good view of the load, the working area and the loading area, whilst maintaining a safe distance from the risk zone between the platform and the body. Note that all cables must be connected from below so that water can't get into the units but condensation can drain out.

All control units must be connected in parallel. The control cable is connected to the circuit card in the connection unit (see electric schema). Install the control current cable from the dashboard of the truck according to the customer's requirements. The control current switch should be located so it is possible to be reached from the ground 10 A (24 V), 15 A (12 V) fuse between the current source and the switch.

The control current cable is connected to a fixed control unit. You can fasten the cable together with the main cable to the hydraulic unit. Connect the main power cable to the starter motor (B+) of the truck, never to the battery. The cable should be protected with a plastic sheath. It must not be fastened together with brake pipes or other electric cables of the truck. When passing through holes the cables must be protected with rubber bushings.

A 150 amp circuit breaker is to be installed on the main power cable running from the battery compartment\*\*. This acts to protect the electrical systems from overloading and the risk of fire.

If you have a spiral cable unit, its cable colours are different (see electric diagram):

If you want an electrically heated spiral cable unit you can order a 5-part cable (spare-part no 21303). Note that the spiral cable unit must have its fastening plate for the wall (spare-part no 20302).

Check that the hydraulic unit is well earthed according to truck manufacturer's instructions (earthing is made through leading in plate, see picture).

If you must lead a spiral cable up through the floor you must protect it with a sheath up from the floor. If you need to use power from the circuit card +ve connection point a fuse must be installed, eg. overload alarm 7.5 Ampere.

Test run all functions from all control units.

Positioning of control unit

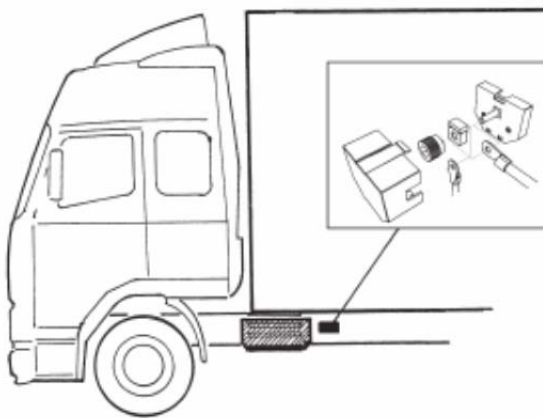
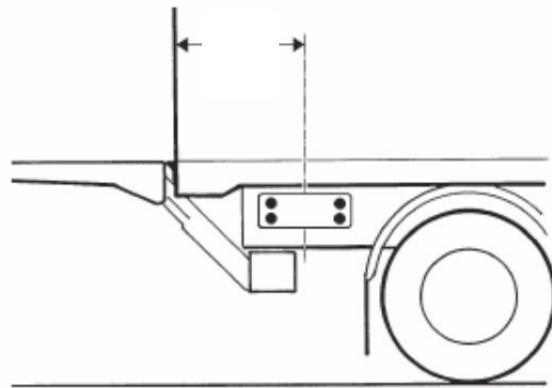

NB. The quick connectors must be well protected and should be positioned inside the vehicle chassis.

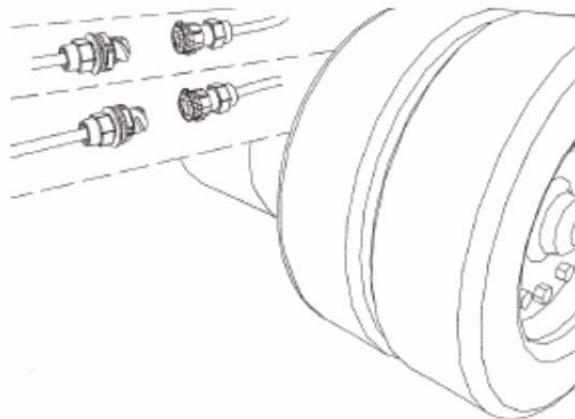



# Chapter 4 Liftgate Installation

## Electric and Hydraulic Diagram

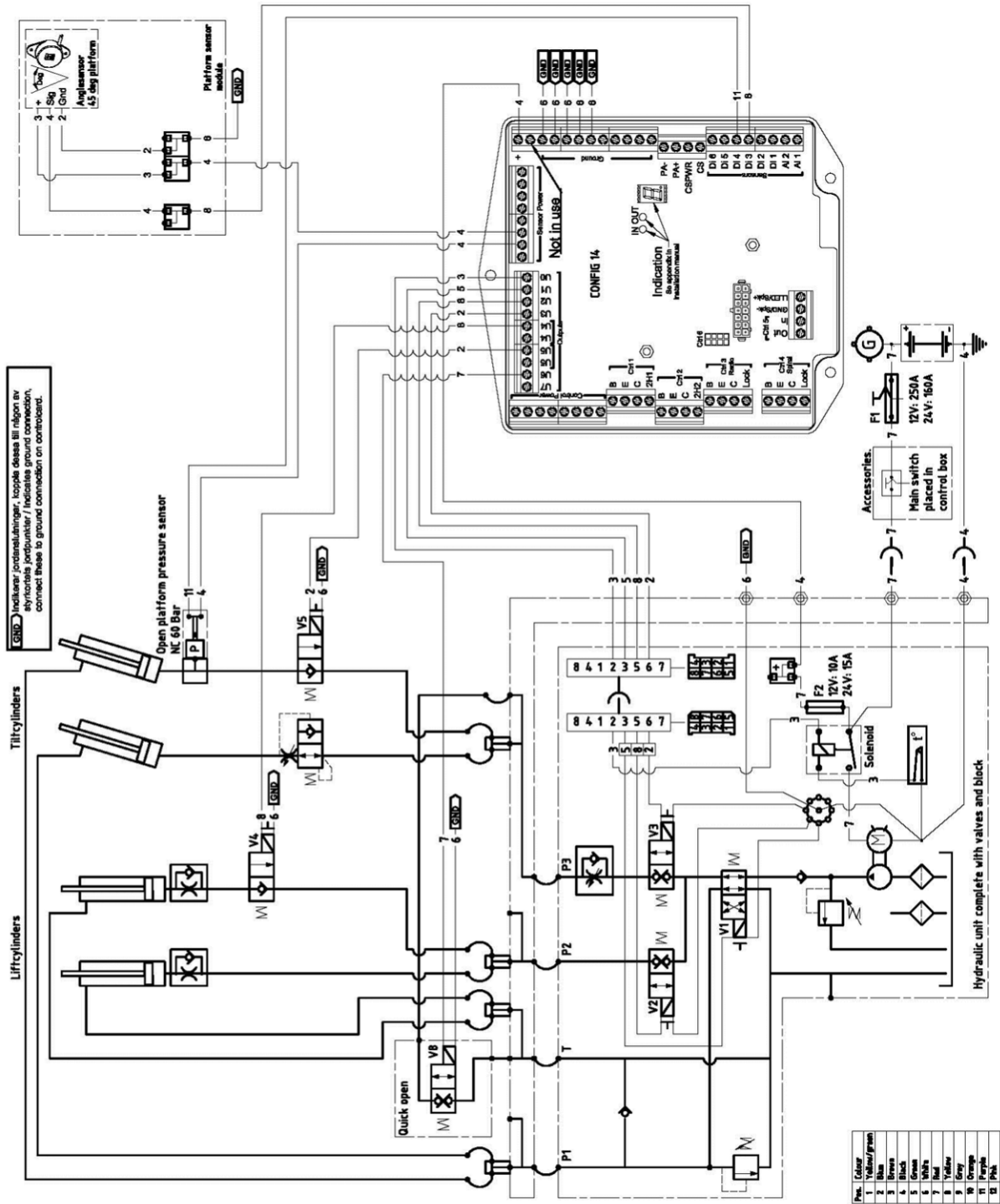

# Chapter 4 Liftgate Installation

## Electric and Hydraulic Diagram (with Auto-tilt)

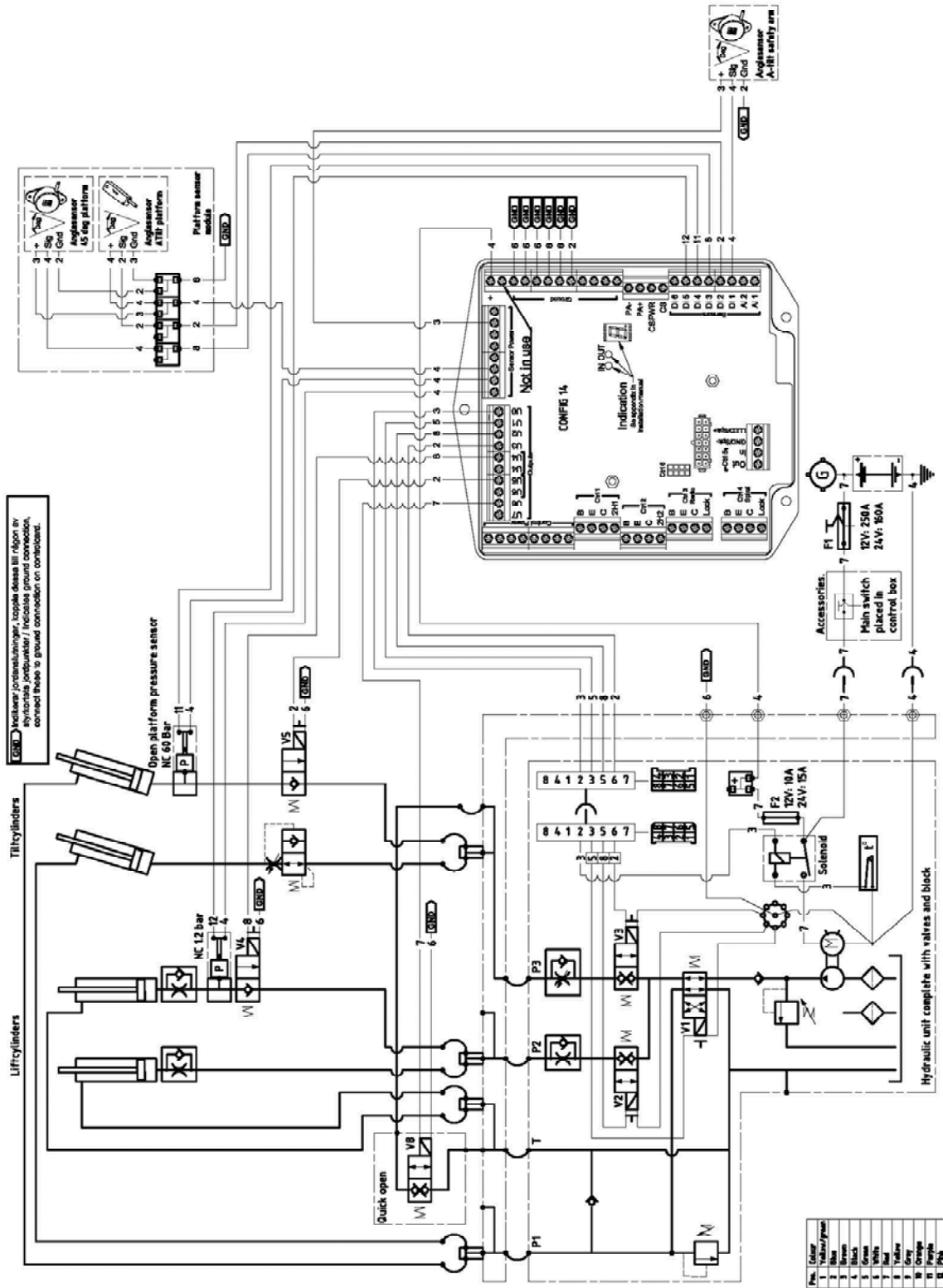

# Chapter 4 Liftgate Installation

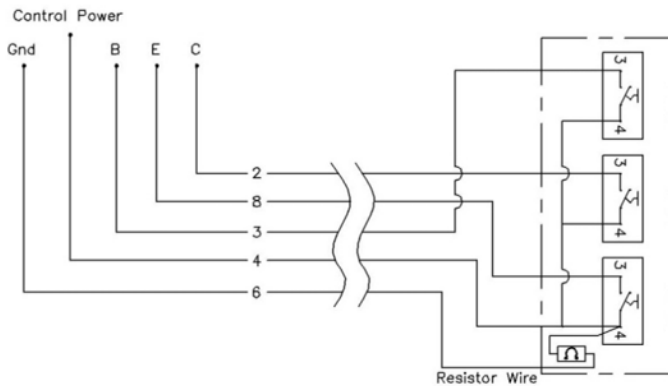

## 3-Button Control Unit (Permanent)

Note: The permanent switch control box comes with a resistor heater wire. It is recommended that this wire be removed and not used.

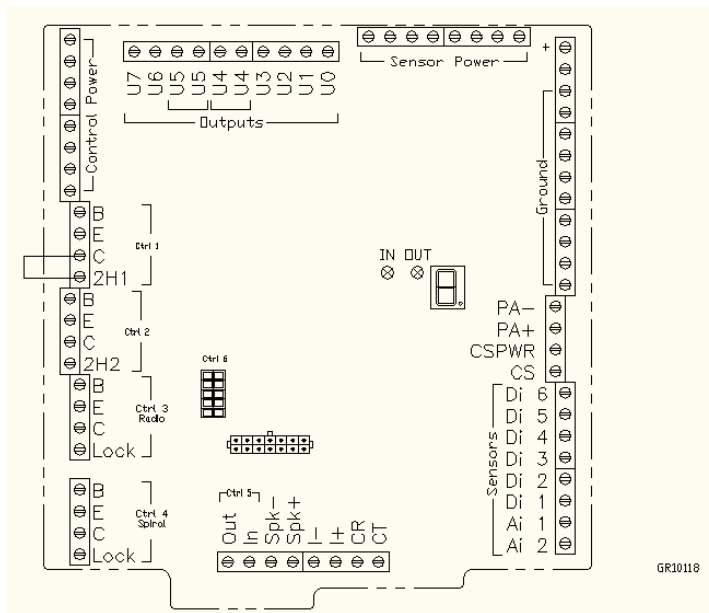

Install the main gate control in control bank 1.

NOTE: For units without a 2 hand switch, connect a jumper between C and 2H1 in control bank 1.

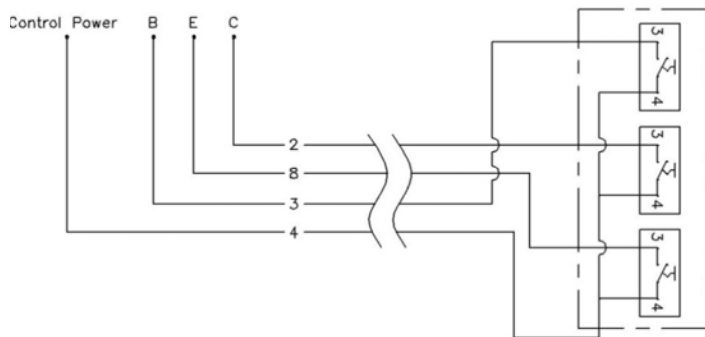

## 3-Button Remote Switch (Spiral Cord)

Install the main gate control in control bank 4.

# Chapter 4 Liftgate Installation

**Install platform angle sensor according the type provided:**

**Internal (mounted on “hockey stick” bracket).**

1. When installing on the steel platform, tap out the plate covering the cut-out in the platform where the sensor module is to be installed. Use a hammer.
2. Position the angle sensor module in the cut-out and ensure that it is correctly positioned in contact with the platform.
3. Install with the supplied screws, use a screwdriver. The screws are self-drilling/self-tapping.
4. Secure cable with cable ties.
5. If necessary, adjust the length of the cable by pushing surplus cable in through the cable lead-through.

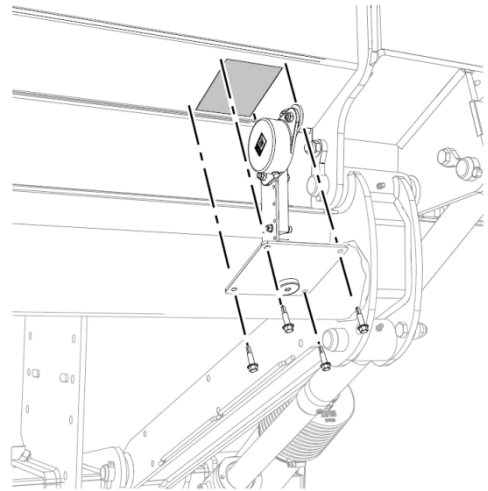

**External Sensor**

1. Bolt sensor to existing bracket on platform.
2. Secure cable with cable ties.
3. If necessary, adjust the length of the cable by pushing surplus cable in through the cable lead-through.

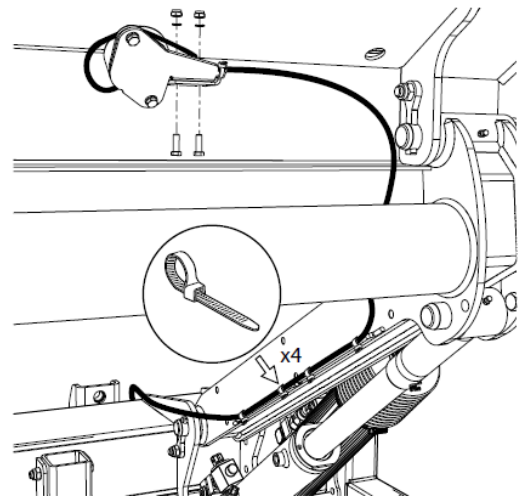

**For units without an inside of deck mounted angle sensor. (Possible on units shipped before 04/2018 only.)**

1. Verify there is a Green or Red jumper wire installed between “Sensor Power” and Di 3 terminals on circuit board.

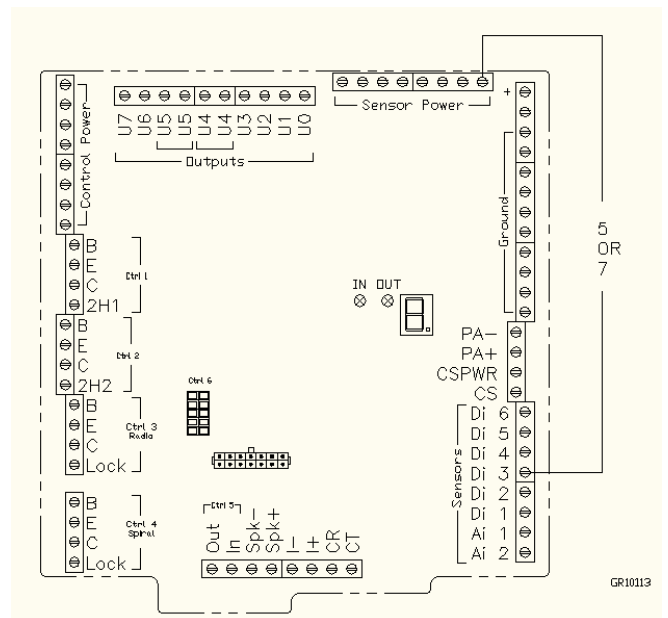

# Chapter 4 Liftgate Installation

## Autotilt units only

### Autotilt sensor to platform mounted bracket

For autotilt units, an additional (rectangular) angle sensor must be installed on the platform's sensor module. This sensor is mounted on the opposite side of the sensor bracket as the round sensor.

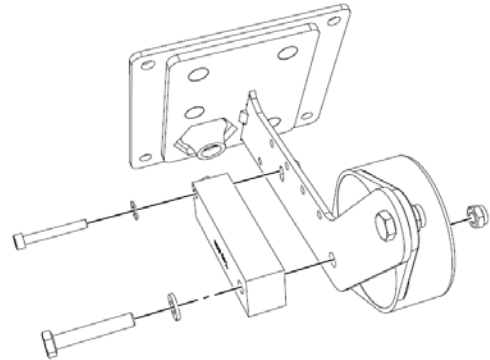

### Adjusting autotilt angle

The autotilt angle is set to 0° as standard. The angle sensor is then installed in line with its bracket, (see image). If required, the position of the sensor can be altered to adjust the autotilt angle up to max. 4°.

1. Undo the sensor's front and rear mounting screws a little.
2. Adjust the position of the sensor by twisting it. The bracket's slot-shaped hole allows adjustment of max. 4°.
3. Tighten both the sensor's mounting screws.

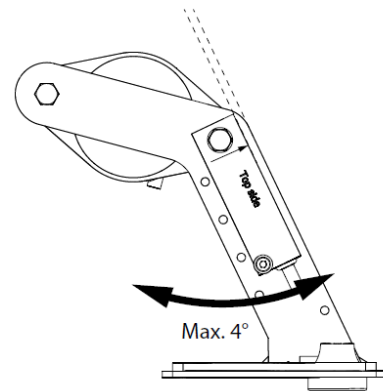

### Connection

1. The platform mounted sensors are connected in parallel using the new supplied splice connectors.

Key.	Colour
1	Yellow / Green
2	Blue
3	Brown
4	Black
5	Green
6	White
7	Red
8	Yellow
9	Grey
10	Orange
11	Purple
12	Pink

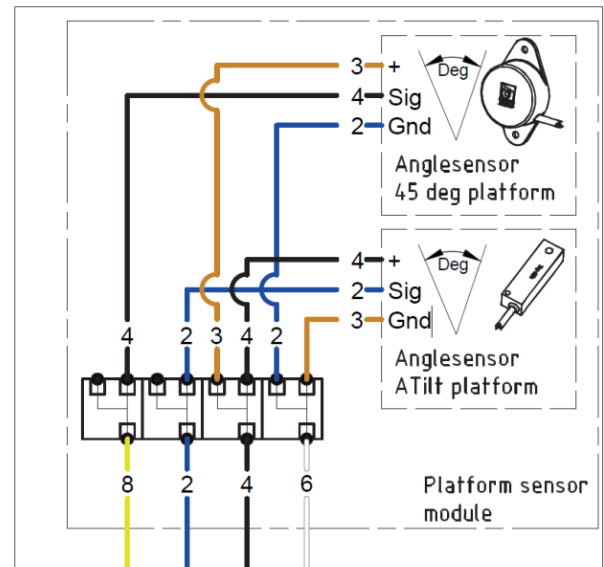

# Chapter 4 Liftgate Installation

## Cable lead-through

In order to be able to install/remove/adjust the cables in the cable grommet, its protective cover must be removed and the five screws loosened.

Remove the protective cover fastened with three screws on the cable grommet.

Loosen the five screws on the cable grommet. Cables can now be installed/removed/adjusted in the grommet.

On installation, the cable must be installed together with existing cabling with cable ties. Ensure the length of the cable is sufficient for moving the control card. The outer sheathing on cable connected to the control card must be stripped 10 inches.

Once all the cables are in their appropriate places in the grommet, retighten the five screws.

Install the protective cover on the cable grommet with the three corresponding screws.

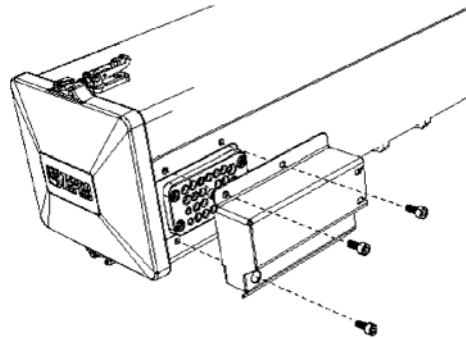

GR03025

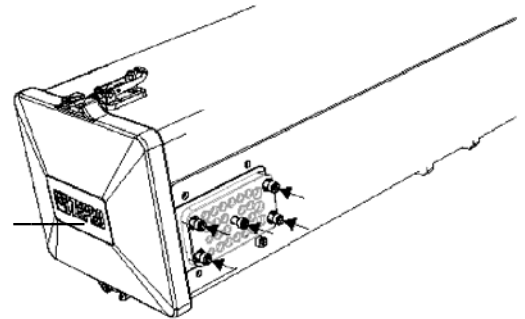

# Chapter 4 Liftgate Installation

## Hydraulic unit and control card

The lift's hydraulic unit and its control card are installed inside the lift's frame. For access during installation, service and repair, for example, the protective cap needs to be dismantled and the hydraulic unit pulled a little way out of the frame.

To access the control card, follow steps 1 to 3; refitting is performed in reverse order. To access the hydraulic unit and oil tank, follow steps 1 to 6; refitting is performed in reverse order.

1. Remove the protective cap, which is secured with two quick-release locks.
2. Disconnect the hydraulic unit, which is secured with two bolts.
3. Pull out the hydraulic unit approx. 6 Inches to access the control card.
4. Remove the control card, which is secured with one wing nut.
5. Carefully place the control card to one side. Ensure that no cables are damaged.
6. Pull the hydraulic unit further out until the tank cap is accessible,

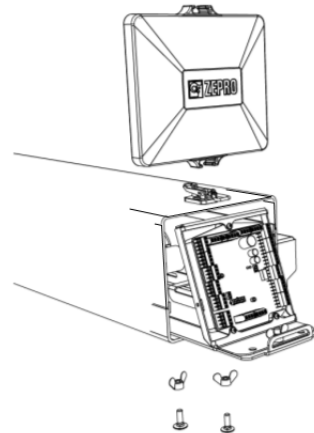

GR03025

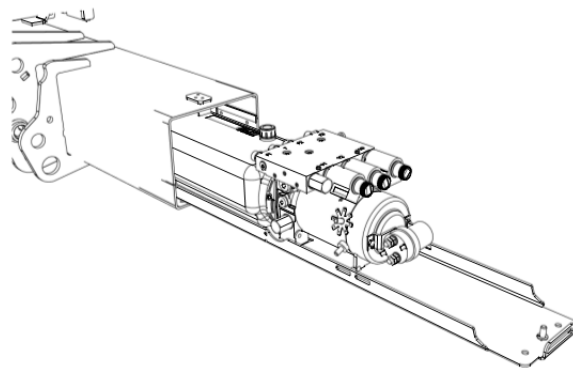

GR03015

# Chapter 4 Liftgate Installation

## Connecting cabin switch and open platform light

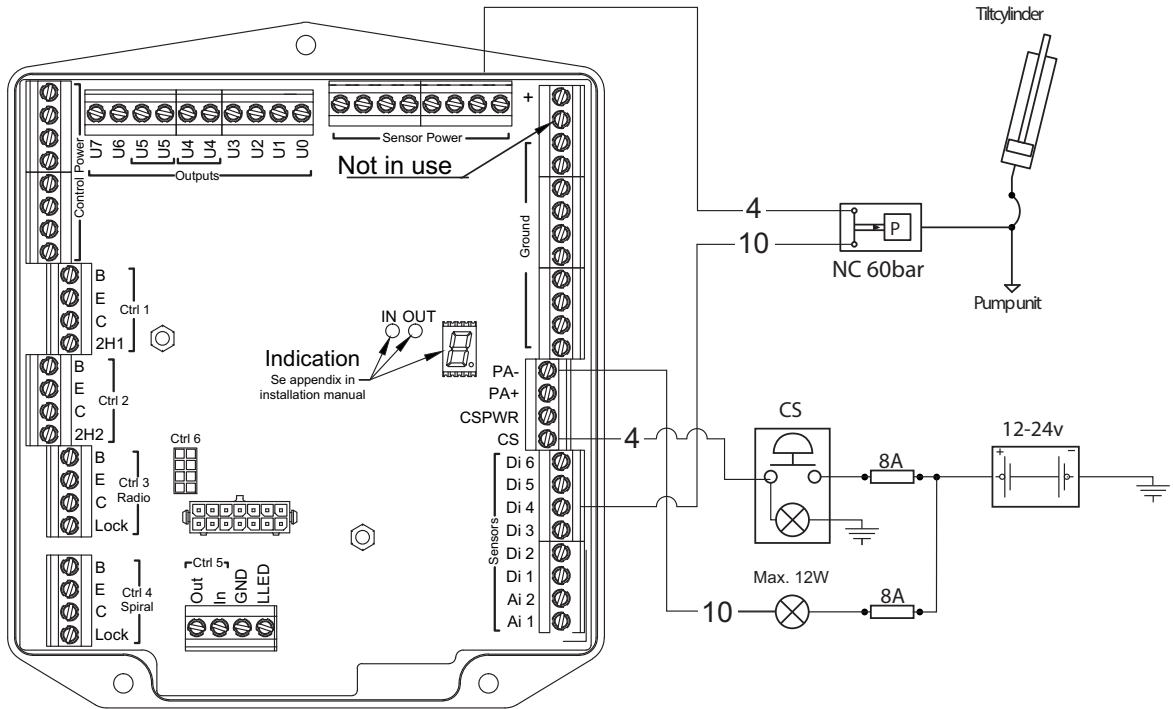

### Cab Shut-Off Switch

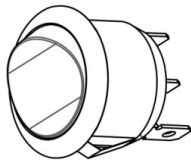

#### NOTE.

Cab Shut-Off Switch  
 Bronze tab connects to ground  
 Center Tab connects to card  
 Outside "silver" tab connects to power.

### Open Platform Light

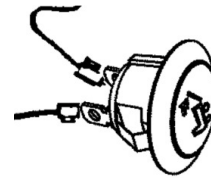

If Cabin switch is not used, add jumper wire

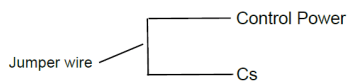

No. / No.	Färg / Colour / Farbe
1.	Gul / Grün, Yellow / Green, Gelb / Grün
2.	Blå / Blue / Blau
3.	Brun / Brown / Braun
4.	Svart / Black / Schwarz
5.	Grön / Green / Grün
6.	Vit / White / Weiß
7.	Röd / Red / Rot
8.	Gul / Yellow / Gelb
9.	Grå / Grey / Grau
10.	Orange / Orange / Orange



# Chapter 4 Liftgate Installation

## Functional schematic drawing

### BZ Gen 7 (config 14)

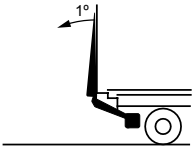
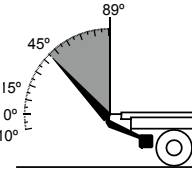
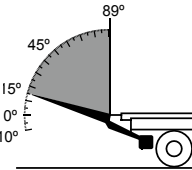
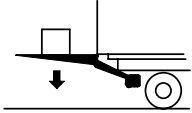
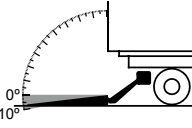
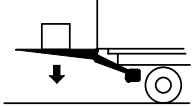
Function	Input signal high	Input signal low (0V)	Output signal	Comment	Control device	Illustration	
Open	1	C+E+2H	Di2+Di3+Di4	U1+U3+U5	Safety, the platform is completely raised and does not move.	Ctrl 1 Ctrl 2	
	2	C+E+2H+Di4*	Di2+Di3*	U0+U1+U3+U5+U6**	Open from 89° down to approx. 45°. Quick opening is activated.	Ctrl 1 Ctrl 2	
	3	C+E	Di3	U0+U1+U3+U5	Opens the body from inside.	Ctrl 4	
Lower	1	E	Di5+Di6	U1+U2+U4		Ctrl 1 Ctrl 2 Ctrl 3 Ctrl 4 Ctrl 6	
	2	Di1+Di3+Di5*	Di6	U1+U2+U3+U4+U5	Autotilt down.	Ctrl 1 Ctrl 2 Ctrl 3 Ctrl 4 Ctrl 6	
	3	E+Di6		U1+U2+U4	Manual down, replaces lower 1 and 2 at jumpered Di6.	Ctrl 1 Ctrl 2 Ctrl 3 Ctrl 4 Ctrl 6	

\* Only required at start of motion; after change of sensor, it is ignored until a re-run takes place.

\*\* 0.2 second delay at output signal.

# Chapter 4 Liftgate Installation

Function	Input signal high	Input signal low (0V)	Output signal	Comment	Control device	Illustration
Tilt down	1 C+E+Di3*		U0+U1+U3+U5		Ctrl 1 Ctrl 2 Ctrl 3 Ctrl 4 Ctrl 6	
Raise	1 B+Di2	Di6	U0+U3	Autotilt up	Ctrl 1 Ctrl 2 Ctrl 3 Ctrl 4 Ctrl 6	
	2 B	Di2*+Di6	U0+U2		Ctrl 1 Ctrl 2 Ctrl 3 Ctrl 4 Ctrl 6	
	3 B+Di6		U0+U2	Manual up, replaces raise 1 and 2 at jumpered Di6.	Ctrl 1 Ctrl 2 Ctrl 3 Ctrl 4 Ctrl 6	
Tilt up	B+C+Di3		U0+U3	Tilting up to approximately 45°.	Ctrl 1 Ctrl 2 Ctrl 3 Ctrl 4 Ctrl 6	
Close	B+C+2H		U0+U3	Close against vehicle body.	Ctrl 1 Ctrl 2	

\* Only required at start of motion; after change of sensor, it is ignored until a re-run takes place.

\*\* 0.2 second delay at output signal.

# Chapter 4 Liftgate Installation

## Restriction of use of control device

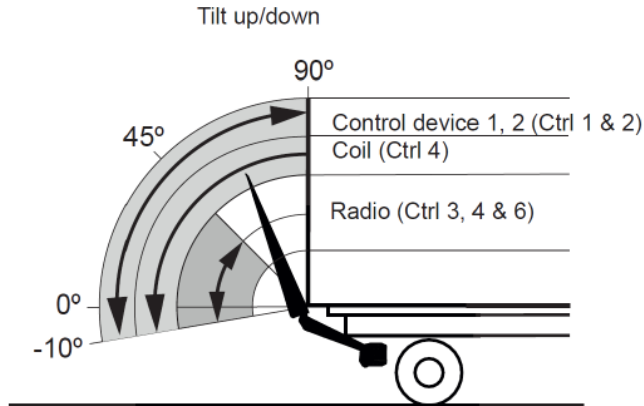

Image 1. Use of radio control device limited by the platform angle.

## Sensor

Name	Position (standard)	Function	Description
Di1	Lift arm	Angle sensor	For autotilt, safety function.
Di2	Platform Module	Angle sensor	For autotilt, platform angle. There is some trimming allowance for the bracket in the platform in order to facilitate adjustment of the platform's autotilt angle.
Di3	Platform Module	Angle sensor	Non-actuated Di3 disables Tilt up with the secondary control device so that the operator must use the two-hand button - 2H along with the primary control device in order to continue to maintain the tilt up function.
Di4	Tilt cylinder	Open platform alarm	Pressure sensor for falling pressure connected to +side of tilt cylinder. In the actuated state, returns the connection signal (+) to Di4 and results in output signal (-) at Pa-. Also phase (+) signal out at Pa+. 60 Bar.
Di5	Lift cylinder	Pressure sensor	For autotilt. 1.2 Bar.
Di6	Control card	Jumper	Jumper for deactivation of Autotilt functions in event of up and down movement.
Cs	Cabin	Activation	No signal in at Cs results in blocked control device terminals. Signal to Cs usually comes from the cabin switch. In individual cases where the cabin switch is not used, the (+) signal comes in to Cs jumpered from (CS PWR) on nearby terminal.
2H	Control devices	Two-hand button	Activated in connection with opening and closing of vehicle body. Used for Quick opening.

# Chapter 4 Liftgate Installation

## Connection unit

### Power save mode

If the control card is not used for approx. 5 minutes, it goes into power save mode. Press any control button for approx. 0.5 seconds to “wake up” the control card again.

### Operating information

All the lift’s functions are controlled and monitored through the control card, which is equipped with an alphanumerical display with a flashing light and 2 red LEDs. These display current operating information. In the event of any operational disturbances, fault codes are displayed to facilitate troubleshooting.

#### The display indicates:

- Active control device
- Fault display
- Program configuration
- Sensors’ current status

#### The flashing light indicates:

- Supply voltage
- Off: No supply voltage
- On: Supply voltage available but CS (cabin switch) is not active.
- Flashing: CS (cabin switch) is active, the system is awaiting input signal.

#### LED 1 indicates:

- Active input, button(s) on control device pressed.

#### LED 2 indicates:

- Active output (approved input signal from control device and sensors), the lift is operated.

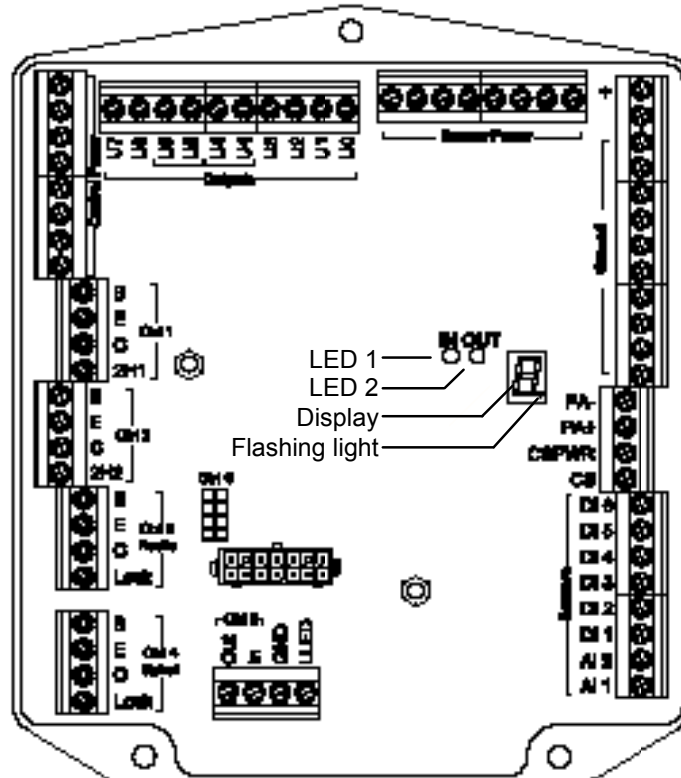

Image 2. The control card is equipped with an alphanumerical display with a flashing light and 2 red LEDs

# Chapter 4 Liftgate Installation

---

## Information codes

Codes are shown on the display in a sequence. First a letter for identification of information, followed by figures or segments for further information and then ending with a pause:

When the CS (cabin switch) is switched on, the current program configuration (P) is displayed first, followed by configuration number. The number of volts detected is then displayed and, after this, the current software version (J), followed by version number.

As long as no control device is used, a scrolling sequence is then displayed, with sensor indication (C), followed by 0-6 segments showing which sensors have a signal.

When a control device is used, the control device being used (1-7) is displayed, followed by which button has been pressed, segments B, C, E or X (X symbolises the 4th button on the respective control device (2h1 for fixed control device 1, 2h2 for fixed control device 2, lock knob for radio control device and coil control device)).

The control devices are symbolised by the figures 1-7.

1. Fixed control device 1, including two-hand button 2h1
2. Fixed control device 2, including two-hand button 2h2
3. Radio control device, External
4. Coil control device
5. Truck slider control device
6. Radio control device, internal module
7. CS (cabin switch)

Once a button has been released, the control system for the current control device is locked for a while to ensure that no other person operates the lift from another control device. During the period the control system is locked for the current control device, its number (1-7) will flash on the display. This primarily applies to radio and coil control devices, as other control devices have such a short locking period that there is hardly time to see the indication.

Coil control devices can be equipped with a locking function. Once the control device has been used, the control system is locked for the current control device until it is unlocked manually from the respective control device's deactivation button. With some configurations, however, the coil control device can, for safety reasons, always tilt the platform down in the event of the operator getting shut inside.

The radio control device is also equipped with a locking function. The control system can then be locked/unlocked by pressing and holding button 5. The lock's status is indicated by the locking function LED, which comes on when the lock is activated. In the event of a fault in the remote control, unlocking can be performed by turning the control power (CS) Off/On.

If the remote control is in the locked position and the lift has been unlocked by turning the control power (CS) Off/On, the lift will be locked again as soon as any button on the remote control is pressed.

### **NOTE.**

The lift remains locked if it loses power and is then started up again, and the number 6 flashes on the control card's display. Unlocking is performed as described above.

# Chapter 4 Liftgate Installation

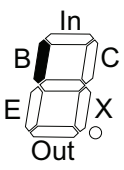
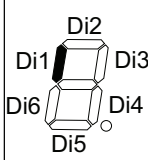
Information codes					
Identification	Code 1	Code 2	Code 3	Information	Other
P (Program configuration)	00-99			Cancelled configuration	
		-		Dividers	
			12/24	Number of volts detected	
J Software version	01-99	_	1-9	Version number	
1-6 (Fixed light) Active control device while operating	1-6			Fixed light (1-6) displays active control device during operation.	
		Segment B, C, E or X.		Segments B, C, E or X are illuminated depending on which button is pressed	
1-7 (Flashing) The control device for which the control system is locked for a while after completed operation.	1-7			<p>Control device for which the control system is locked.</p> <p>This primarily applies to radio and coil control devices, as other control devices have such a short locking period that there is no time to see the indication.</p> <p>The number will stop flashing when one of the current control device's buttons are pressed.</p> <p>If the control card has been without voltage and receives the voltage again when the CS (cabin switch) is switched on, "7" will flash on the display and the control card is locked until the Off/On on the CS is operated.</p> <p>1-6 = Ctrl 1-6 7 = CS</p>	
C Sensor indication	Segment			<p>1-6 segments indicate sensors.</p> <p>On - signal in.</p> <p>Off - no signal in. 0V.</p> <p>(See electrical and hydraulics diagrams for information about the location of the sensors).</p>	

### Example of sequence of information codes:

Program configuration: 01, Voltage detected: 12V, Software version: 09

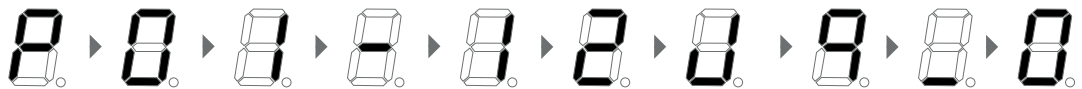

### Example of sequence with sensor indication:

Sensor indication: C, Detected sensor: Di1

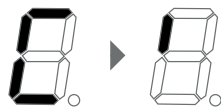

### Example of sequence with control device indication:

Control device: 2, Detected button: B



# Chapter 4 Liftgate Installation

## Fault codes

If a fault arises, the fault code is shown in the display in the form of a letter for identifying the fault, followed by numbers and/or number segments for further information, followed by sensor indication (C) in accordance with the previous page.

In fault codes E, F and U, the numbers (1-9) show which control device/output the fault code refers to.

1. Fixed control device 1, including two-hand button 2h1
2. Fixed control device 2, including two-hand button 2h2
3. Radio control device, External
4. Coil control device
5. Truck slider control device
6. Radio control device, internal module
7. CS (cabin switch)
8. Control Power
9. Sensor Power

If the system discovers several faults, only the fault code for the fault with the highest priority will be shown automatically. The display is prioritised in the order in the table below, L/H, E, F and A.

When the CS is switched off, the system will browse through a list containing the five most recent faults detected before the display goes off after approx. 5 minutes, the control card then goes into power save mode.

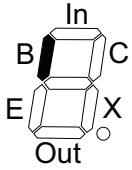
Fault codes					
Identification	Code 1	Code 2	Code 3	Information	Other
L Low battery voltage	07-35			Voltage measured	
H High battery voltage	07-35			Voltage measured	
E Control device locked	1			Fixed control device 1 (incl. two-hand button 2h1 if they are monitored)	
	2			Fixed control device 2 (incl. two-hand button 2h2 if they are monitored)	
	3			Radio control device, external	
	4			Coil control device	
	5			Truck slider control device	
	6			Radio control device, internal module	
	7			CS (cabin switch)	
			Segment		

# Chapter 4 Liftgate Installation

Fault codes					
Identification	Code 1	Code 2	Code 3	Information	Other
F Output short-circuited/high current	0-9			Which output has short-circuited/has high current. Fault code is reset automatically if the function in question is running (function verified).	1-7 U0-U7, displayed only after the respective output/function has been active. 8 Control power 9 Sensor power
Output not connected/cable breakdown	0-7			Which output is not connected/has cable breakdown. Fault code is reset automatically if the function in question is running (function verified).	Displayed only after the respective output U0-U7 has been active.
A Internal fault	0-				Contact support if the lift does not function.

All fault codes can be reset manually by switching Off/On the CS (cabin switch). Fault codes F0-F7 and U0-U7 are reset automatically if the function in question is running (function verified). Fault codes L and H are reset automatically if the battery voltage becomes correct. Fault code E is reset automatically if the control system has not received any signal from the relevant control device for 6 minutes.

### Example of sequence of fault codes:

Output No. 3 short-circuited.

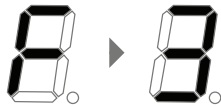

### Control devices

If a control device button is held down for too long, the control device is blocked and cannot be used for a number of minutes. Fault code E flashes on the display. The fault is also indicated on a non-active coil control device with a lock button, if this is connected to Ctrl 4. The LED on the coil control device then flashes the same number of times as the number on the control device in question, see the list in section "11.2.2 Fault codes" on page 8.

**Example:** Control device 2 is blocked, the LED on the coil control device then flashes twice, goes out for a moment, flashes twice again, etc.

Coil control device's LED	
Fixed light	The coil control device is active
Extinguished (weak glimmer)	The coil control device is not active
Flashing	One of the other control devices is blocked



# Chapter 4 Liftgate Installation

## INSTALLATION OF COMPRESSION TERMINALS

Cut power cable (red) and ground cable (black) to length and install compression terminals.

Strip 7/8" to 1" of insulation from end of cable.

Slide heat shrinkable tubing onto cable.

Insert bare wire into compression nut until it seats.

**Note:** Copper wire should be flush with, or slightly past, the nut.

Grip nut with wrench and turn terminal until nut seats.

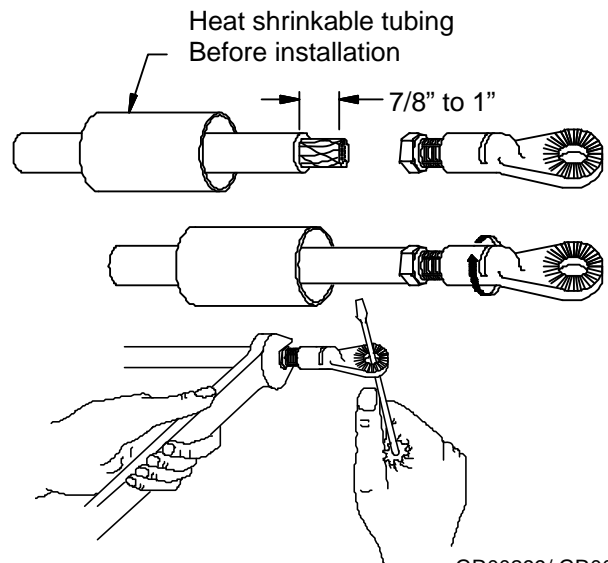

Position heat shrinkable tubing over terminal and end of cable.

Shrink tubing using electric heat gun or torch.

**Note:** To reduce chance of damaging tube and cable, a heat gun is recommended.

Apply sufficient heat to produce thin bead of sealant all around tube edges.

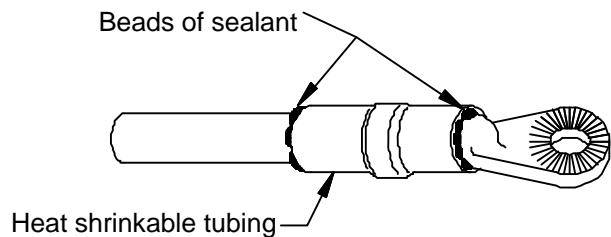

# Chapter 4 Liftgate Installation

## INSTALL TERMINALS TO BATTERY

Connect red 2GA cable to red quick connector behind main frame.

Route positive battery cable from lift unit to battery box.

Connect the end of the battery cable from the liftgate to the circuit breaker as shown.

Apply a generous amount of Dielectric Grease to all Positive (Hot) Battery terminals and Circuit Breaker terminals.

Secure all battery cables to the vehicle frame with the cable ties provided.

**IMPORTANT!** Original equipment ground cable furnished on vehicle should be at least a number 2 Ga. An auxiliary ground cable should be added between the engine block and the vehicle frame if engine is not adequately grounded. When there are two or more batteries in the installation, all cables connecting the batteries together must be 2 Ga. or heavier. This includes all original equipment batteries on this vehicle.



**Protect wires from any sharp edges or holes that may abrade insulated covering of wires.**



**Secure battery cable so it does not come near, or in contact with, other vehicle wiring, fuel lines, brake lines, air hoses, exhaust system, etc.**

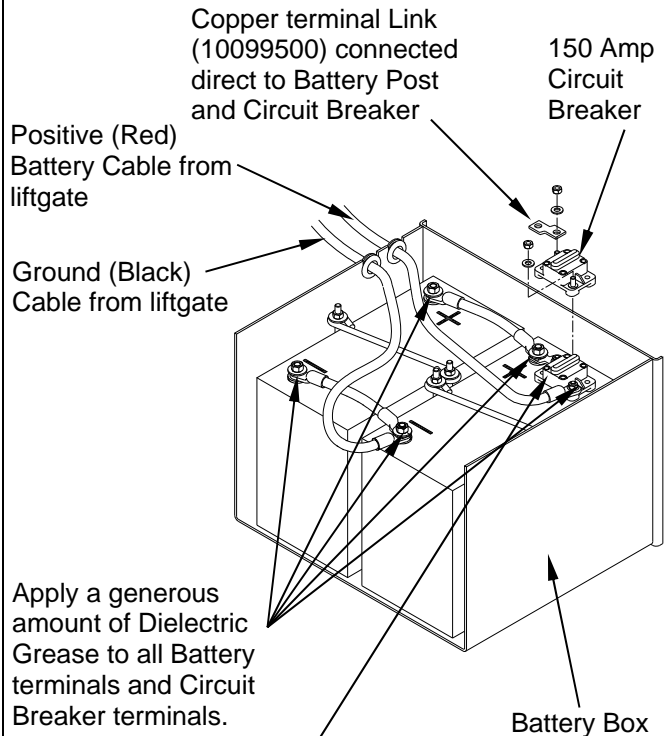

**NOTE:** Circuit Breaker is to rest solidly on the battery to prevent vibration during transit.

# Chapter 4 Liftgate Installation

## REMOVE TRANSPORT PLUG

Replace transport plug from oil tank with breather plug.  
 Check oil level, oil level should be 1/2" below top of oil tank.  
 Add oil if needed.  
 Do not over fill.

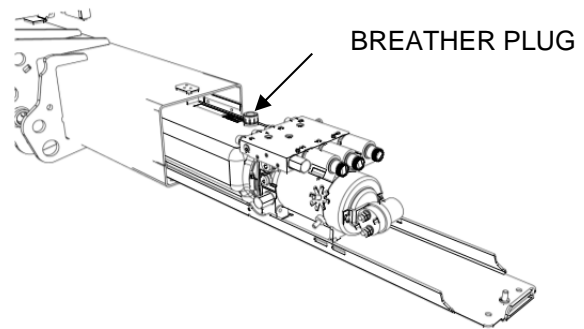

GR03015

### Recommended Fluids

Temperature Range	Acceptable Fluids
0° to 120° F	Waltco Biodegradable Liftlube™ part #85803860
	Shell Tellus S2 V 32
	Chevron Rando HDZ 32
-20° to 90° F	Waltco Biodegradable LiftLube Arctic part #85803866
	Waltco All Season Hyd Oil Part 85803867
	Shell Tellus S2 V 15
	Mobil DTE 10 Excell 15 Chevron Rando HDZ 15

Fill reservoir

- Fill with recommended fluid or equivalent.
- Fill the reservoir to within 1/2" from the top.
- Fluids are available from the Waltco parts Dept. 1-800-411-5685 [www.waltco.com](http://www.waltco.com)

#### NOTE:

**Do not use the following fluids:**

- Brake Fluid**
- Power steering fluid**
- Automatic Transmission Fluid (ATF)**

Rev 08

## OPERATING GATE WITHOUT BATTERIES

If the liftgate needs to be operated before the batteries are installed, temporary battery and battery charger can be used.

**Note!** Never operate liftgate only with battery charger, this can cause damage to electrical parts.

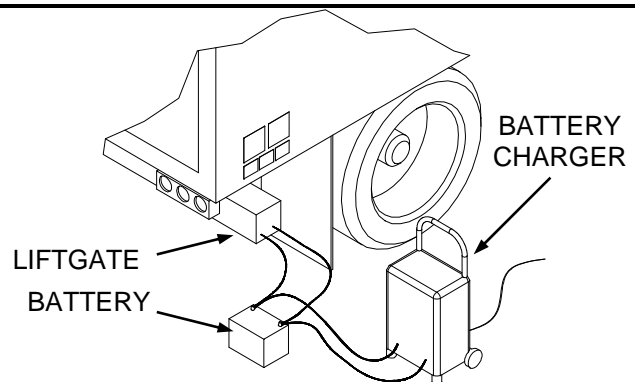

GR01091

# Chapter 4 Liftgate Installation

## INSTALL REAR SILL EXTENSION

Cut extension so it will extend to within  $\frac{1}{2}$ " of each side to vehicle body.

Position and weld extension, centered on door opening.

**Note:** If the full door seal kit, or flip-up door option are to be used, they will use a different type of sill extension.

**Note:** For vehicles with swing doors, refer to the section in the back of this chapter "Swing door application".

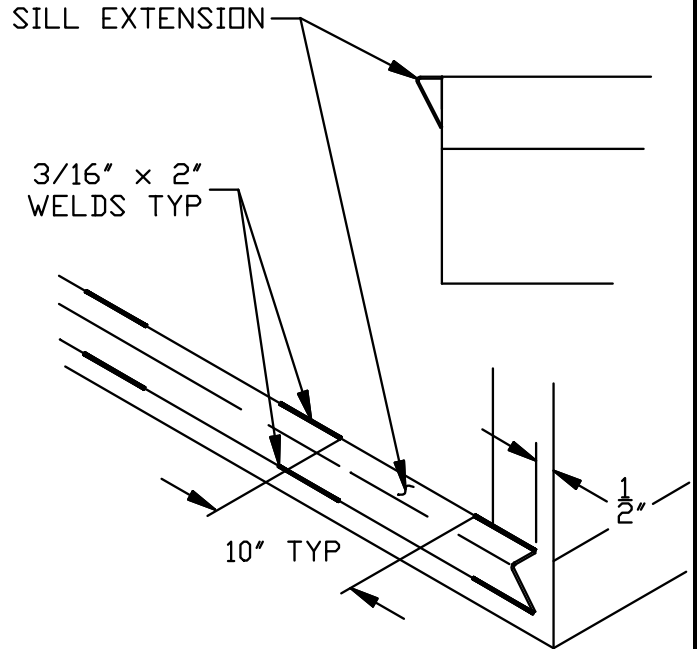

GR00086

## POSITIONING OF PLATFORM

Using the raise switch, raise lift arms up off the ground as shown.

Lift Platform Using an Over-Head Crane or Forklift as shown.



**Other means may be used to support the platform in position. ALWAYS verify the safety of your supporting method before proceeding.**

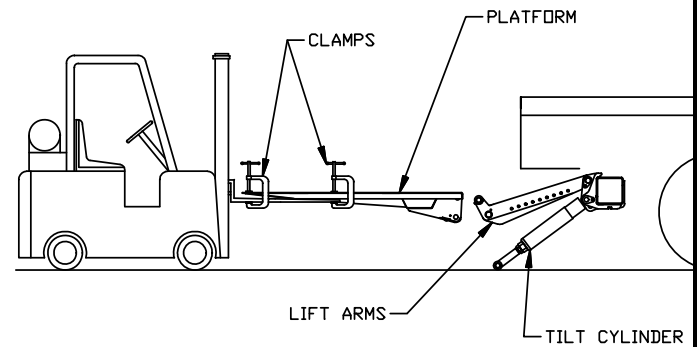

GR00087

## INSTALLATION OF LIFT ARMS

Align the Lift Arms with the upper holes in the Platform Hinges.

Pin the Lift Arms to the Platform Hinges as shown.

Secure pins with lock nuts.

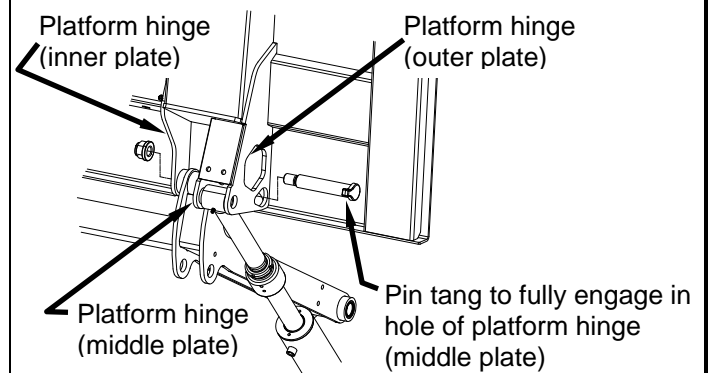

GR01762

# Chapter 4 Liftgate Installation

## INSTALLATION OF TILT CYLINDERS

Manually Pivot the Tilt Cylinders into position.

Extend or Retract the Tilt Cylinders as needed, to align rod eye with lower pivot holes in Platform Hinges, by using the Raise and Tilt or Lower and Tilt switches.

Install Tilt Cylinder Pins, washers, support wheel and lock nuts as shown.

Pin tang to fully engage in hinge (middle plate)

Platform hinge (middle plate)

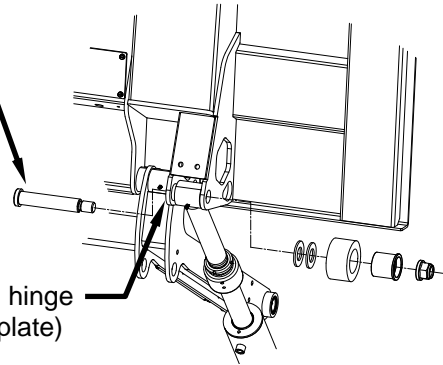

GR01763

## ADJUSTMENT OF PLATFORM GAP

Bring platform horizontal with bed of vehicle. Be careful not to damage rear sill extension.

The platform and rear sill must have a gap between 1-3/4" and 1-15/16".

Determine how much and in which direction the platform must be moved.

Lower the platform to the ground.

1-3/4 - 1-15/16

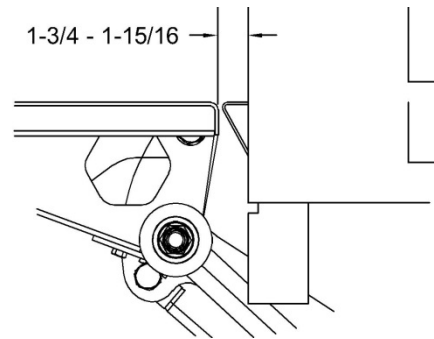

GR00837

Loosen mount bracket bolts.

Move mount frame as necessary.

Torque bolts to 85 ft. lbs.

Raise Platform horizontal with bed of vehicle and tilt up to transport position. Check to see that the gap requirements have been met.

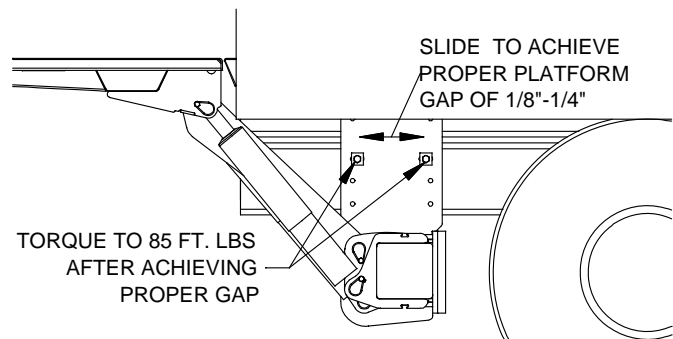

GR00091

## FINAL INSTALL OF MOUNT BRACKETS (BOLT ON METHOD)

Lower platform to the ground.

Use mount brackets as a template and drill the remaining holes in the chassis frame.

Install a minimum of 6, 1/2" grade 8 bolts in the outer holes and torque to 85 ft. lbs

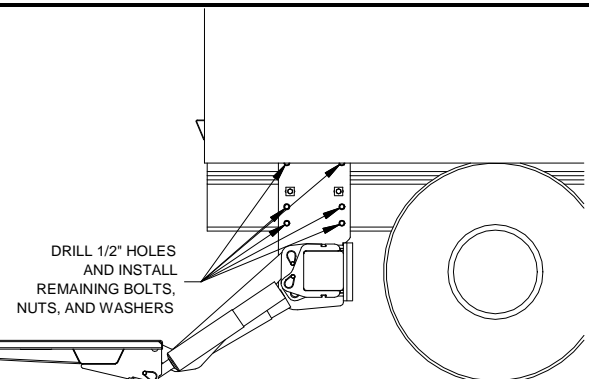

GR00092

# Chapter 4 Liftgate Installation

## WELDING, CUTTING AND GRINDING

Before doing any metal work:

Pull pump unit out from main frame and cover with non flammable material.

Cover piston rods with non flammable material.



**Welding, torching or grinding can damage cylinders, hoses or electrical system.**

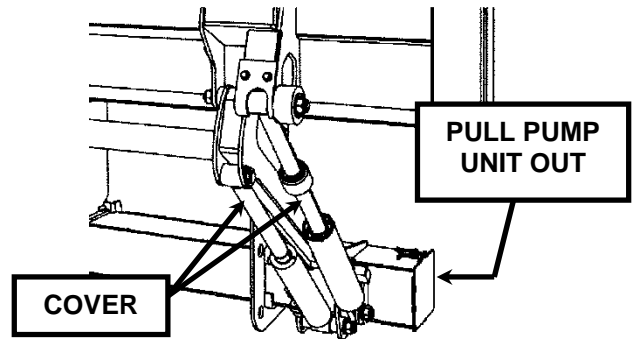

GR00508

## WELDING

Welding machines ground point must be connected as close to welding point as possible.

Do not allow ground current to go through pivot pins, bearings, cables or hydraulic hoses.



**Welding current can melt cables or burst hoses causing personal injury.**

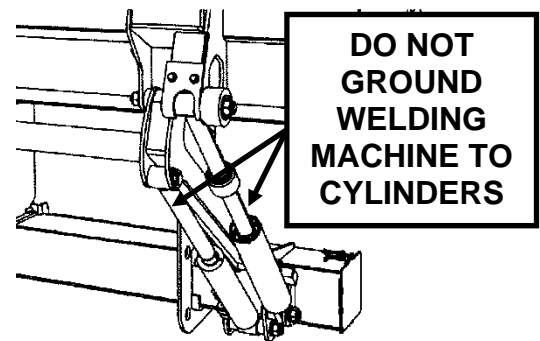

GR00508

## PAINTING

**IMPORTANT!** Do **not** paint the cylinder piston rods!

Any paint applied to piston rods will eventually effect the operation of liftgate by contaminating the entire hydraulic system, causing blockages in valves, pump, filter, cylinders, and hoses.

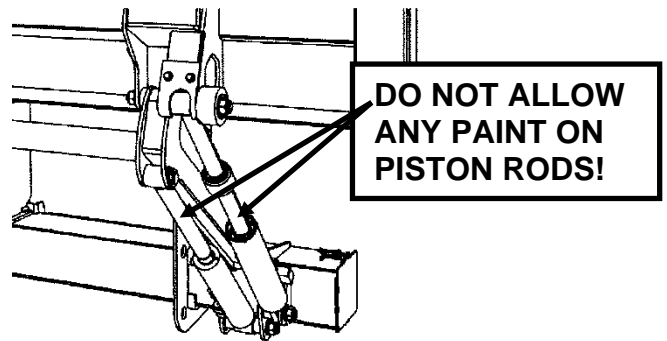

GR00508

## FINAL INSTALL OF MOUNT BRACKETS (WELD METHOD)

Lower platform to the ground.

Note: top of mount plate may be trimmed off if necessary to weld three (3) sides of the vehicle frame. Verify that 5-1/2" vertical weld can be made on each side of bracket.

Weld mount brackets to chassis frame 100% on three (3) sides as shown.

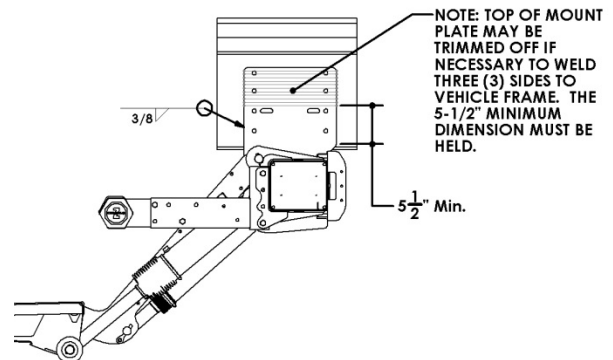

GR10119

# Chapter 4 Liftgate Installation

## INSTALL UP STOPS

Liftarms movement up must be limited mechanically. Rear sill is not strong enough to withstand forces from liftgate.

Use 2" x 2" x .25 tube (or similar) to limit up movement of lift arm as shown.

Material for up stops is not provided.

Raise platform to bed height.

Position up stops on top of lift arms and against vehicle chassis frame.

Tack weld up stops to chassis frame and lower platform to the ground.



**Verify that hydraulic hoses or wires will not get crushed between lift arms and up-stops.**

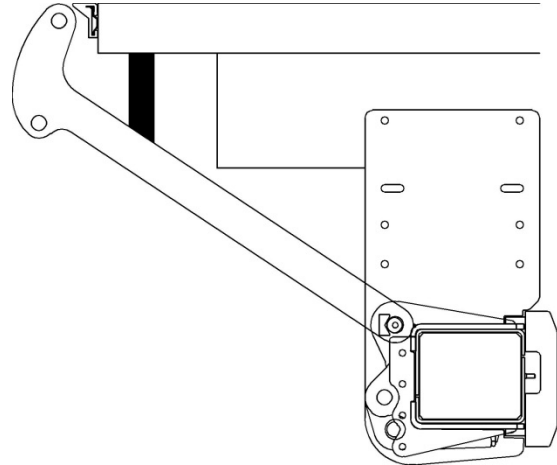

GR01169

Add support beam or gusset to up stop to prevent up stops bending.

Material for this is not provided.

**IMPORTANT!** Add support to up stops to prevent bending.

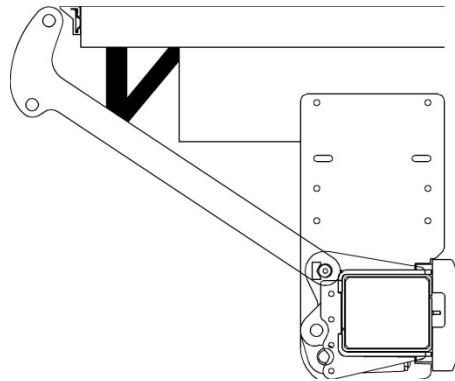

GR01170

Make sure that up stops will contact lift arms as shown on drawing.

**IMPORTANT!** Up stop must contact lift arms as shown.

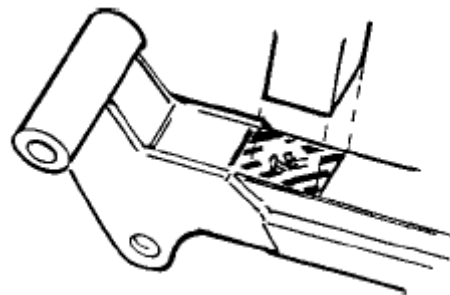

GR00455

# Chapter 4 Liftgate Installation

## ELECTRONIC AUTOMATIC TILT

For units equipped with Auto-tilt, install the angle sensor. The angle sensor should be positioned on the lift arm as shown.

**Note:**

When installing on the left arm, the sensor's cable input must be facing upwards.

When installing on the right arm, the sensor's cable input must be facing downward.

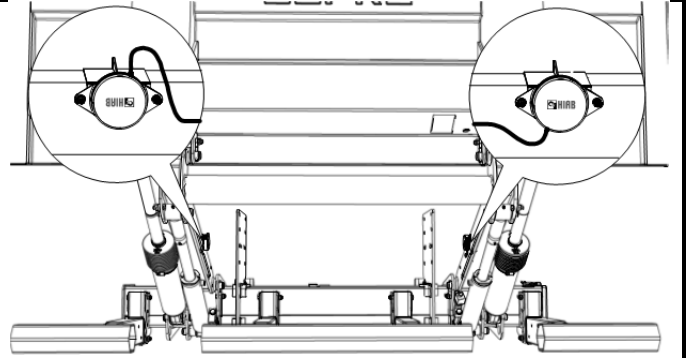

GR03023

## CONSTRUCTION OF TILT CYLINDER

1. Screw
2. Adjustable collar
3. Washer
4. Lock screw (x3)
5. Ring
6. Ring's Lock Screw

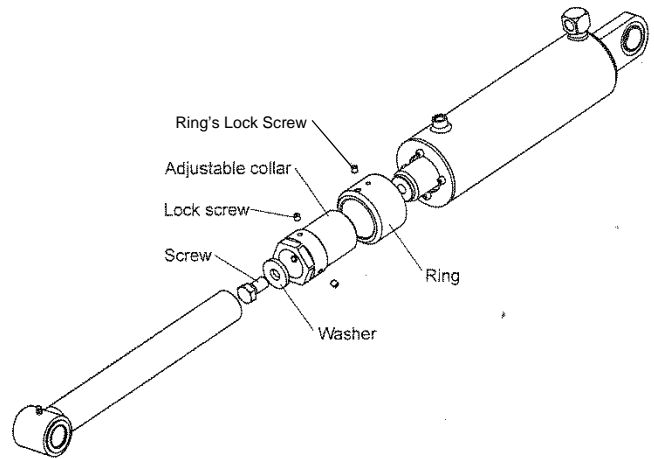

GR02803

## ADJUSTING TILT UP ANGLE

**Note:** Do not adjust the tilt cylinders before they are installed onto the platform. Tilt cylinders are pre-adjusted at the factory.

Position and install cylinder as shown:

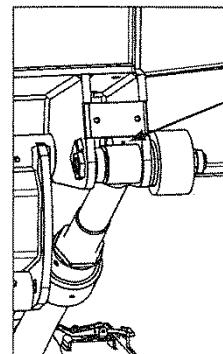

**Note:** Make sure the grease zerk is facing upwards

GR02813



# Chapter 4 Liftgate Installation

## **IMPORTANT!**

Tilt up the platform until it closes **without tilting over 90°**. The tilt cylinders should be fully extended. **If platform will tilt over 90°** tilt cylinders must be adjusted in order to prevent damage of over tilting.

Cylinder adjustments should be made when the cylinders are fully pressurized.

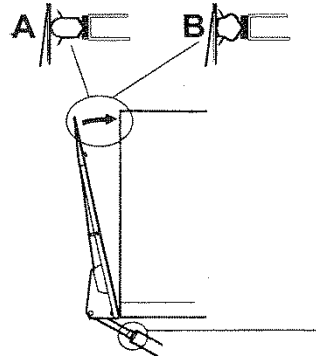

GR02814

Loosen rubber bellows and loosen (3) lock screws.  
Turn adjustable case counter-clockwise to decrease length of tilt cylinder or clockwise the increase length.

\*Adjust until the platform reaches top sill of truck (GR02814, detail A) Fine Adjust until platform fits tightly against top sill (GR02814, detail B)

Always adjust left and right side equally.

(“\*” Only for trucks with ceiling and/or top sill)

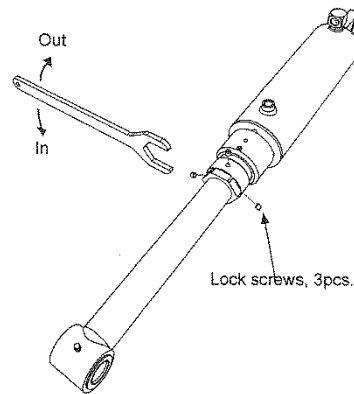

GR02815

Tighten lock screws and measure the exposed cylinder threads; not to exceed more the 1-3/16”

Lock screws torque is between 26.4 – 44.4 ft/in



**Do not adjust to expose more than 1-3/16” of threads.**

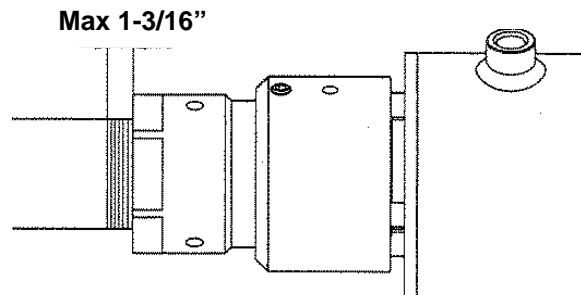

GR02828

# Chapter 4 Liftgate Installation

## ADJUSTING TILT DOWN ANGLE

**Note:** To obtain the correct tilt down function, it is necessary to follow the previous instructions which ensure a correct 90° tilt angle up against the truck's body.

Cycle the lift up until it reaches floor level.

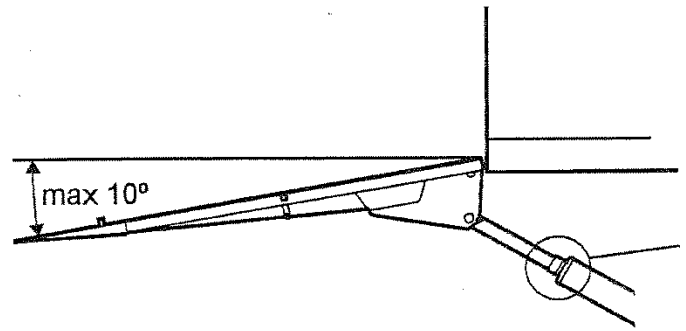

GR02829

Loosen the cylinder ring's lock screw (1). Screw the ring out in the direction of the platform (2)

Tilt the platform a maximum of 10° below the horizontal as shown in Fig-GR02829

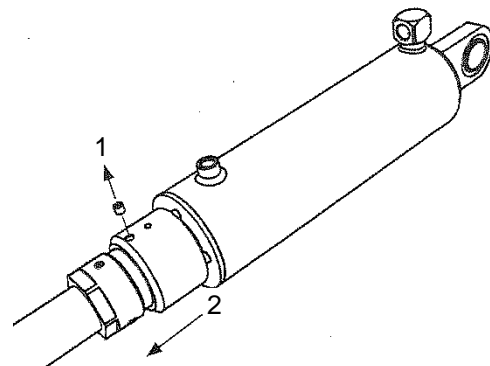

GR02816

Tighten the ring to the top of the cylinder (3) and then tighten the lock screw into the ring (4) after tilt down angle is established

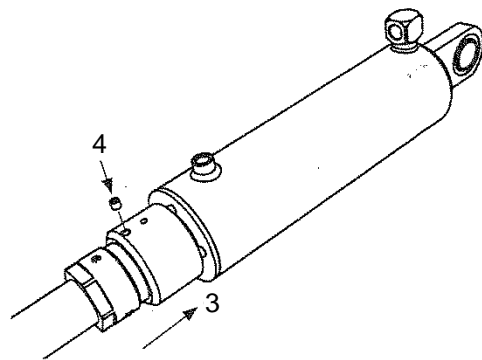

GR02817

Reassemble the rubber bellows as shown to the following A dimensions:

Liftgate Model:	A: (inches)
Short Arm	$7\frac{3}{32} \pm \frac{3}{16}$
Long Arm	$11\frac{13}{16} \pm \frac{3}{16}$

Test all the functions of liftgate.

Make sure that platform fits properly against top sill (if so equipped).

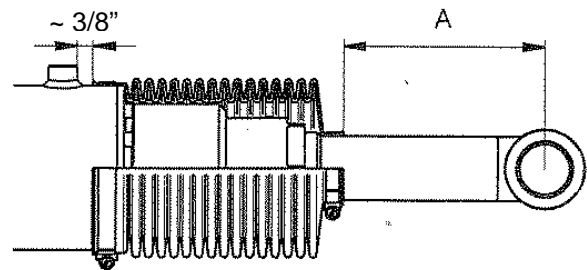

GR02818

# Chapter 4 Liftgate Installation

## PLATFORM RUBBER STOPS

If the vehicle is not equipped with at least side seals, rubber stops for the platform must be installed on the corner post of the body at a height of  $\frac{2}{3}$ 's the height of the closed liftgate platform on both corner posts

Install rubber stops as shown and adjust tilt cylinders so that the platform firmly contacts the stops when fully closed.

Space rubber stops out from corner post as may be required. Spacers not provided.

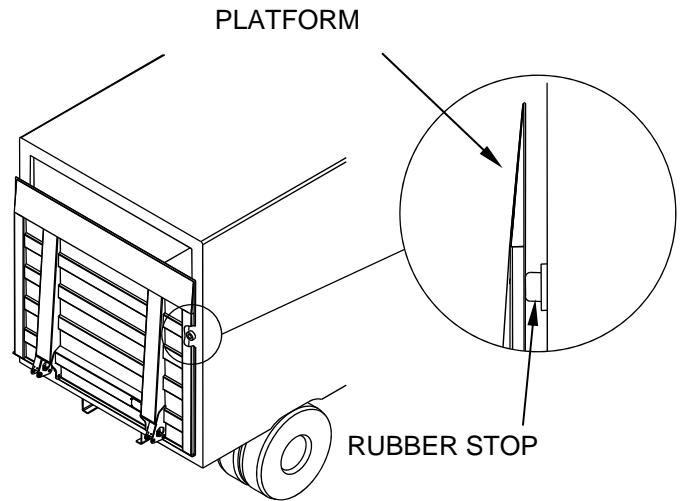

GR01605

## FLAT BED APPLICATIONS

On flat bed applications, vehicle must be equipped with corner posts.

Make sure that the corners post are strong enough to support forces from platform.

Install rubber stops as shown and adjust tilt cylinders so that the platform firmly contacts the stops when fully closed.

Space rubber stops out from corner post as may be required. Spacers not provided.

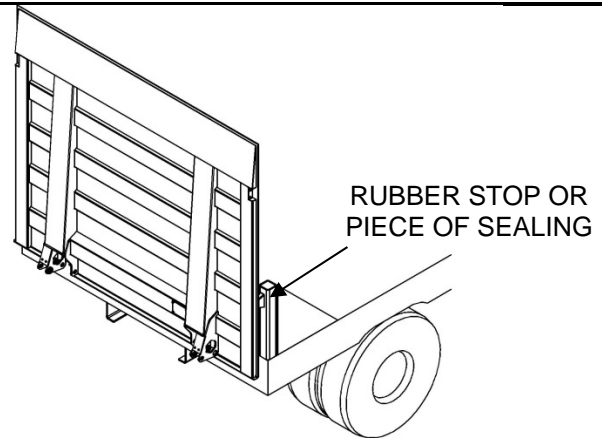

GR01606

# Chapter 4 Liftgate Installation

## INSTALLATION OF 3-PIECE BUMPER

Install (3) piece bumper as shown.

**NOTE:** All (3) pieces need to be installed!

Bumper bars have three height adjustment possibilities; all bumper bars must be installed to same height position. Every bumper bar must be secured with three bolts and lock nuts (supplied).

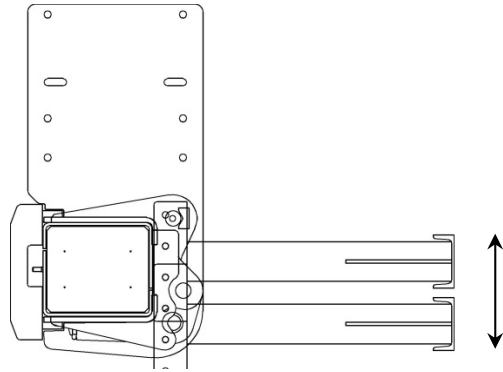
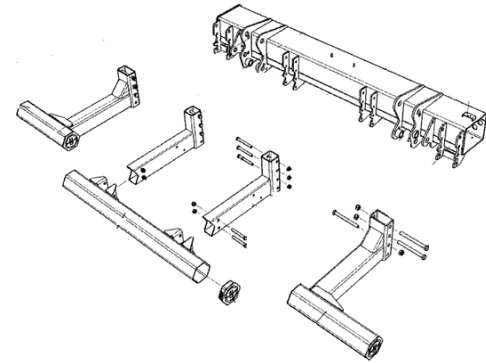

GR02819 & GR00507

## SWING DOOR APPLICATION

Platform must be spaced away from the vehicle such that when the liftgate is in the closed position it does not contact the door hardware.

**Note:** Sill extension is not used with vehicles with swing doors.

**Note:** Rubber stops for platform must be spaced out if bridge piece is used.

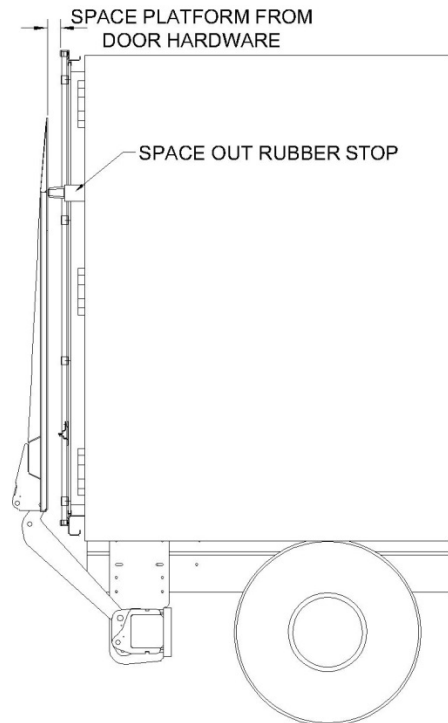

GR00111

# Chapter 4 Liftgate Installation

## BRIDGE FABRICATION

A bridge may be fabricated approximately as shown to reduce the gap between the platform and sill in the previous step.

The bridge must be notched for door hardware. It must also be wide enough and constructed such that its strength is not compromised by the notching.

**Note:** Widening bridge further spaces platform away from vehicle.

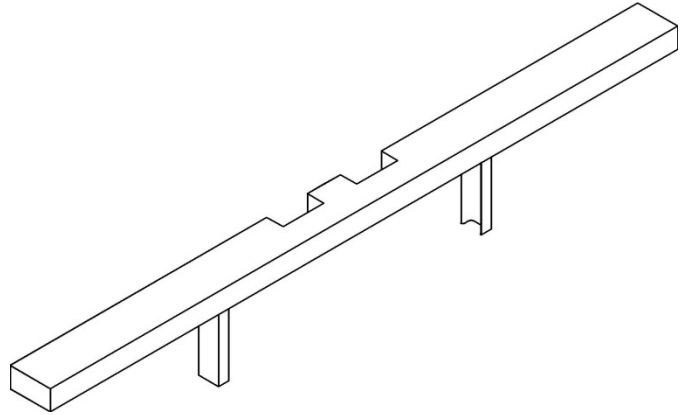

GR00112

## INSTALLING BRIDGE

There must be approximately 5/8" gap between platform and bridge to prevent interference.

It is recommended to also leave approximately 1/2" gap between platform and rear sill to prevent interference.

**Note:** It is recommended to clamp or tack weld to test position before final installation.

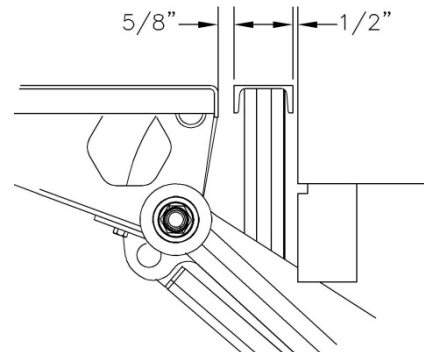

GR00838

# Chapter 4 Liftgate Installation

## FINAL INSTALLATION OF BRIDGE

Weld bridge to lift arms 100% as shown.

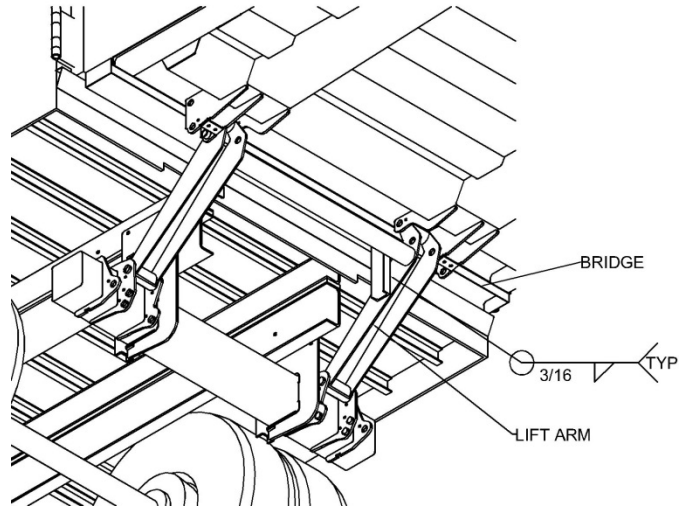

GR00114

## LOADING AREA

Bridge will pivot over back of platform when lowered.

Mark back of platform as a no loading area as necessary.

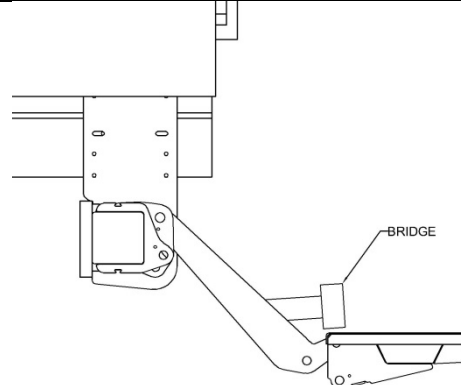

GR00115

## OPERATION CHECK

- Turn shut-off switch on (located in cab)
- Always make certain area in which platform will open is clear
- Push and hold tilt switch then lower switch to unfold platform

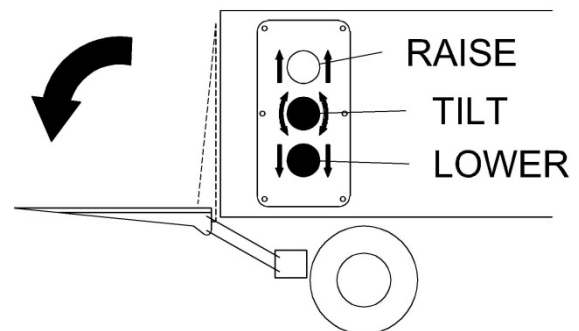

GR00106

# Chapter 4 Liftgate Installation

## TO RAISE AND LOWER PLATFORM IN LOADING POSITION.

- Push raise switch to raise platform  
Or
- Push lower switch to lower platform

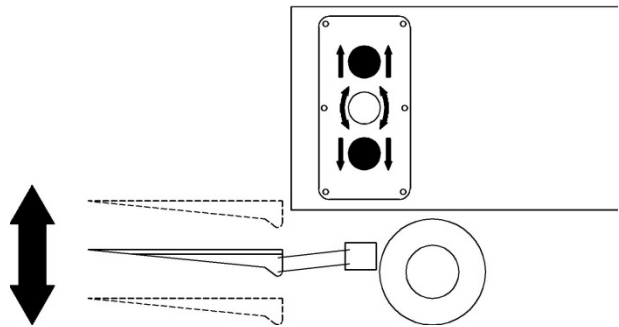

GR00107

## TO TILT PLATFORM UP AND DOWN.

- First push and hold tilt switch, then simultaneously push raise switch to tilt platform up.  
Or
- First push and hold tilt switch, then simultaneously push lower switch to tilt platform down.

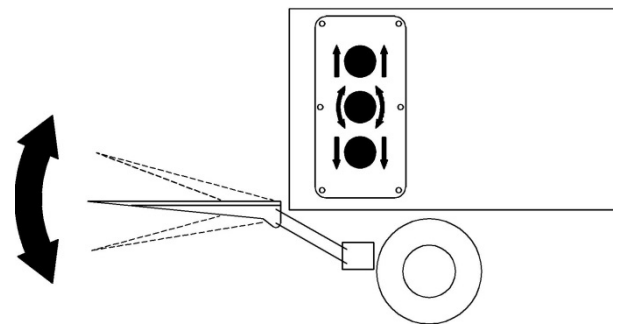

GR00108

## TO FOLD PLATFORM TO CLOSED POSITION.

- Make certain platform surface is clear of all objects.
- Raise platform to bed level with raise switch.
- Push and hold tilt switch then simultaneously push raise switch to close platform.
- Turn shut-off switch off

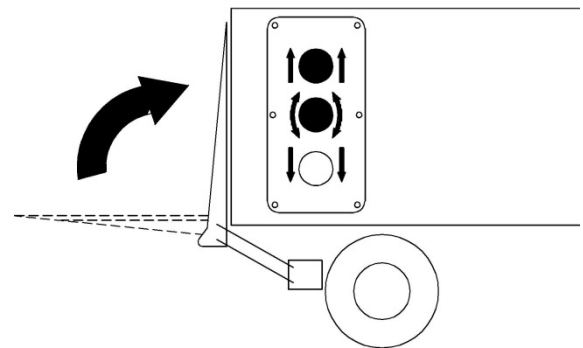

GR00110

# Chapter 5 Placement of Decals

## INSTALLATION OF CONTROL DECALS

Install all decals listed below. Be certain they are installed in the proper location and are legible.



All decals must be in place and legible or all warranties are void.

Each of the following four (4) decals are to be positioned in a conspicuous place near the control switches as shown.

80100850 – Safety Instruction Decal

80101451 – Operation Decal

80100828 – Important Decal

80101370 – Hazard decal

One (1) of the following three (2) decals is to be positioned in a conspicuous place near the control switches as shown.

80101415 – BZ-33 Capacity Decal

80101416 – BZ-44 Capacity Decal



**If your liftgate is equipped with dual controls, an additional Safety Instruction decal (80100850) is to be placed in a conspicuous place near the second set of controls.**

To maximize decal adhesion to surfaces:

- Surface must be dry and clean
- Firm pressure must be applied to decal
- Minimum surface temperature 65°  
Heat gun may be used to heat surface

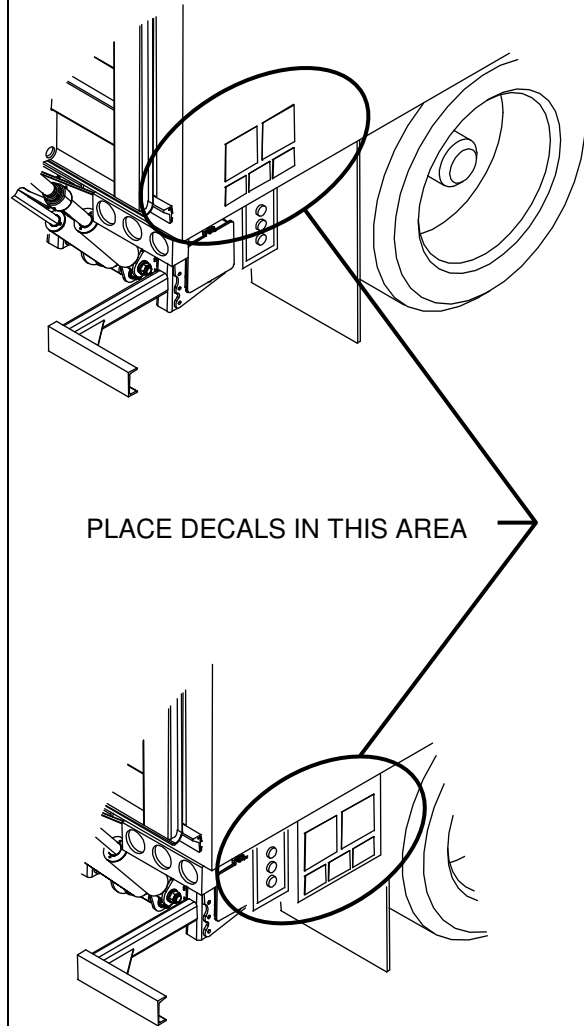

GR02913

## INSTALLATION OF DRIVE-OVER WARNING DECAL

The following decal is to be positioned in a conspicuous place near the control switches as shown.

80100592 – Drive Over Decal



**If unit is equipped with drive over kit decal 80101330 must be used in place of decal 80100592.**

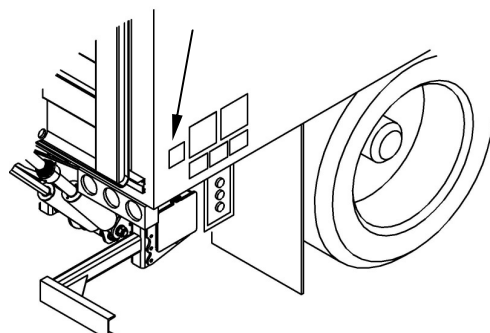

GR02913A



# Chapter 5 Placement of Decals

## INSTALLATION OF PLATFORM DECALS

The following decals are to be placed on the underside of the platform and both sides of vehicle as shown.

75089296 – Stand Clear Decal (4)

One (1) of the following three (2) decals is to be positioned in a conspicuous place on the bottom of the platform as shown

80101415 – BZ-33 Capacity Decal

80101416 – BZ-44 Capacity Decal

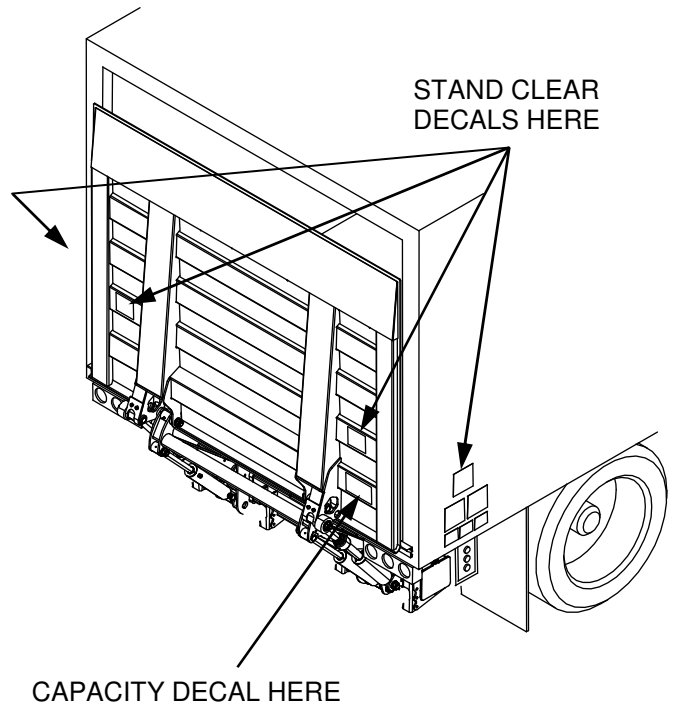

GR00511

## INSTALLATION OF SAFETY TAPE

Tape (Z20290) is to be placed on the sides of platform so it is visible from the side and back of vehicle as shown.

**IMPORTANT!** Safety tape must wrap around side of platform as shown.

**IMPORTANT!** Safety tape must wrap around side of platform as shown.

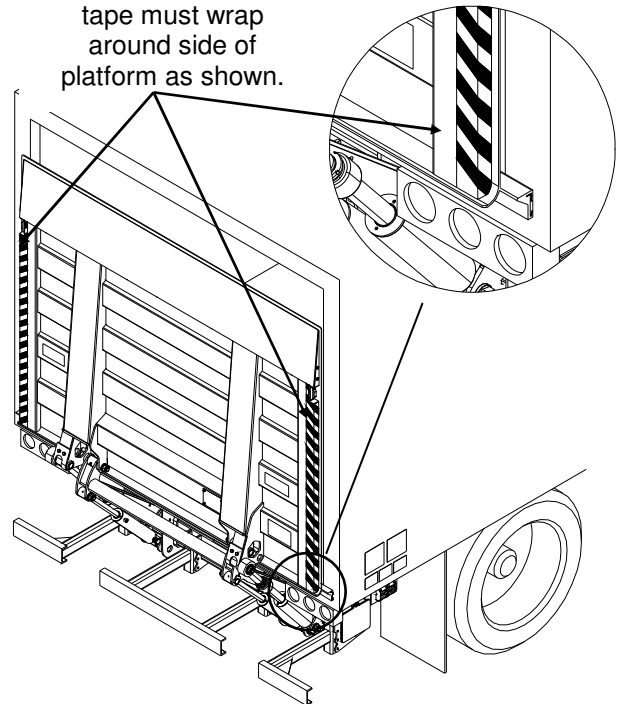

GR00511

# Chapter 5 Placement of Decals

## SAFETY TAPE AND FLAGS

Tape (Z20290) is to be placed on the sides of platform so it is visible from the side.

Locate corner flag mount brackets (Z20273), one on each side of platform and drill (3) holes per bracket into platform as shown. Use bracket as a template.

Using slotted head screws provided (three per bracket), install flag mount brackets as shown.

Slide flags (75089905) into mount brackets and crimp ends of each bracket to prevent flags from sliding out.

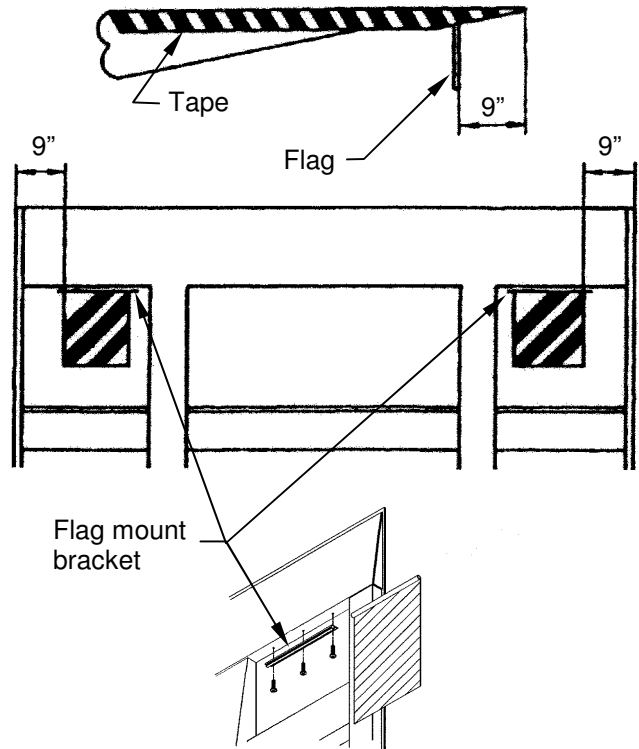

GR00043 & GR01761

## SHUT-OFF DECAL

The following decal is to be placed next to the liftgate shut-off switch as shown.

75089267 – Liftgate Shut-Off Decal

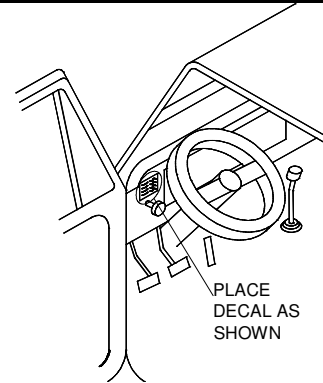

GR00121

## CIRCUIT BREAKER DECAL

The following decal is to be placed next to the liftgate circuit breaker as shown.

80100829 – Circuit Breaker Decal

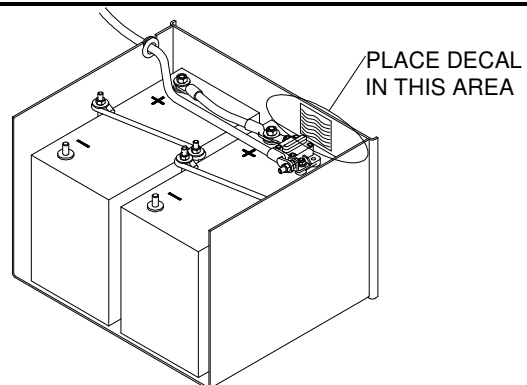

GR00122

# Chapter 6 Lubrication

## LUBRICATION INSTRUCTIONS

12 grease fittings should be lubricated with a grease gun per the lubrication schedule below.

**Note:** All fittings should be greased with the platform in the stored position.

SUGGESTED MINIMUM LUBRICATION SCHEDULE (IN DAYS)			
Monthly Cycles	Light Duty	Med. Duty	Heavy Duty
250 Or Less	45	30	21
250-350	30	21	14
350-450	21	14	7
More Than 450	Contact Factory for Instructions		

**Note:** If unsure of duty or cycles always lubricate more frequently.

1. Tilt cylinder, lower pin
2. Lift cylinder, lower pin
3. Lift arm, lower pin
4. Tilt cylinder, upper pin
5. Lift cylinder, upper pin
6. Lift arm, upper pin

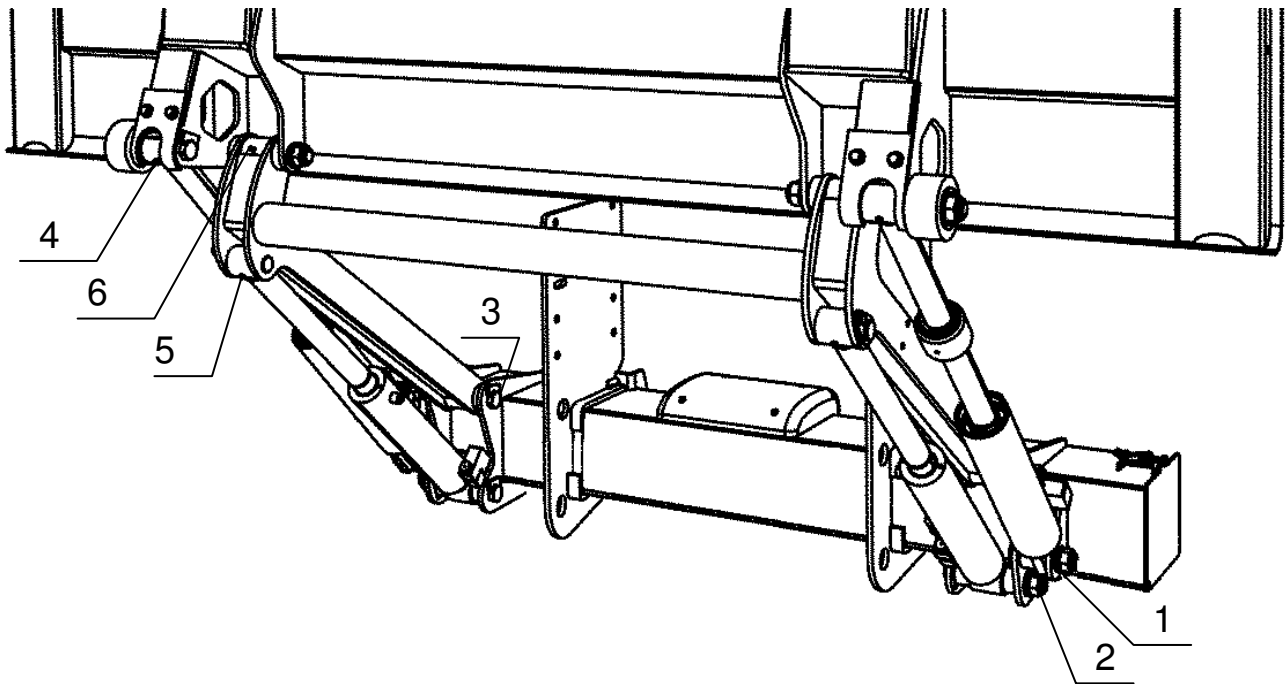

GR00508

# Chapter 7 Final Inspection List

---

## IMPORTANT

**All of the following items are to be checked and verified before installation is complete.**

---

- A. All welds are properly done.
  - B. All bolts, nuts, and screws are tight and torqued to the proper specification.
  - C. Control boxes and shut off switch function properly.
  - D. All phases of the liftgate's operation work properly.
  - E. Platform raises level to the truck bed and the gap between the platform and sill extension is the correct distance.
  - F. All decals are accounted for and legible.
  - G. Lights are installed and operate properly.
  - H. Vehicle meets all state and federal standards.
  - I. Owner's Manual is in the vehicle.
  - J. Pump reservoir is full of oil.
  - K. All grease fittings are lubricated.
  - L. All hydraulic connections are tight.
  - M. Up stops, Drive-Over Bars, Rubber Stops and Platform Bridge are installed and operate properly. (if applicable)
  - N. Pump and Motor Slide tray is tightly latched.
  - O. Liftgate has been operated through its entire operational cycle several times and operates evenly, freely and smoothly throughout the entire operating cycle with no unusual noise or vibration.
- 



**Do not use liftgate if any of the above are not checked and verified. If you have any questions not covered in this manual, contact your nearest Waltco distributor, or the nearest Waltco factory.**

# BATTERY KIT INSTALLATIONS

80101387

## DETERMINE BATTERY AND PUMP LOCATION, AND CABLE ROUTING

Determine where pump unit and battery box will be located. Make certain hydraulic hoses supplied will reach pump.

Your installation may use only one cable supplied with liftgate, or, it may also use a cable supplied with the trailer kit.

### Truck with auxiliary batteries:

Cable supplied with liftgate will be cut into two lengths to reach from pump to auxiliary batteries and to vehicle batteries.

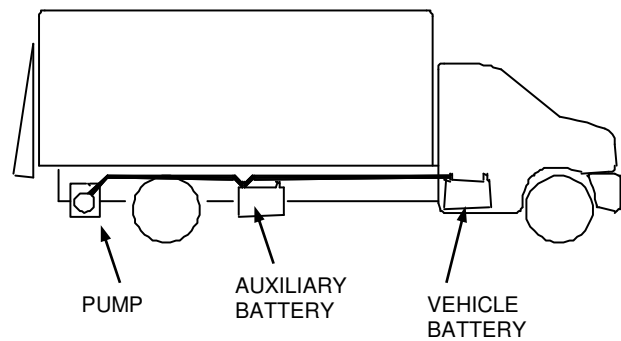

### Trailer with auxiliary batteries:

Use cable supplied with liftgate from pump to auxiliary batteries.

Use cable supplied with trailer kit from auxiliary batteries to nose of trailer.

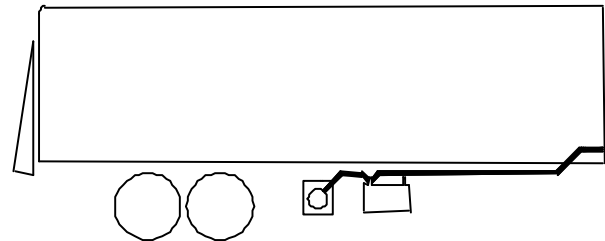
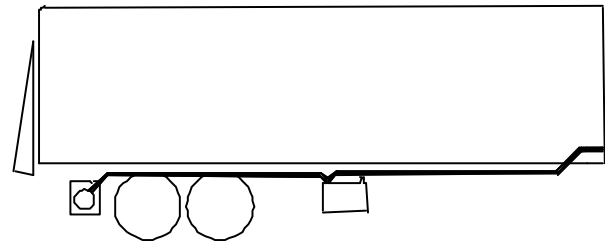

**Note: Auxiliary batteries on trailers are to be mounted "mid-ship" on the trailer.**

GR01389

# BATTERY KIT INSTALLATIONS

80101387

## BATTERY AND PUMP BOX INSTALLATION

Locate battery box and pump box in a suitable location under the vehicle body (refer to previous page.)

Weld hanger channels to body crossmembers.

### Hint:

To save space, hanger channels can be cut down and boxes moved closer together as shown.

Install batteries.

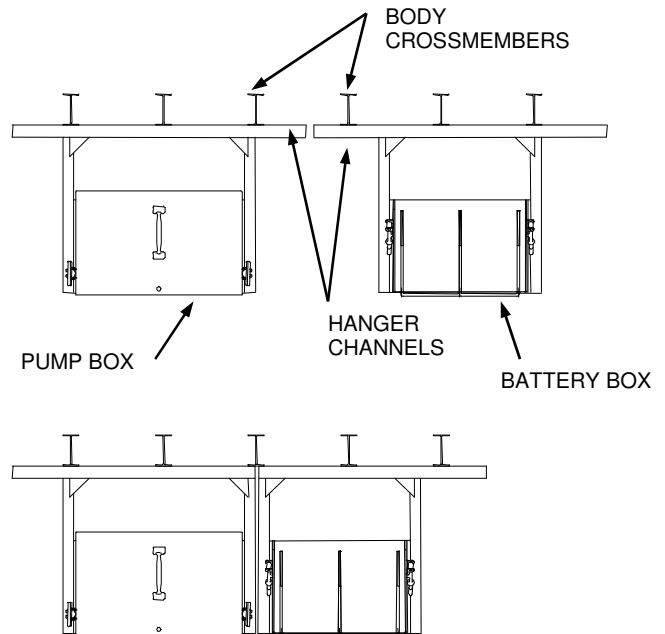

GR01390

## INSTALLATION OF BATTERY CABLE

Install battery cable supplied with liftgate to the pump starter solenoid.

### For trucks:

Route cable to vehicle batteries, cut to desired length.

Cut cable to reach auxiliary batteries, and cut remaining piece to reach from auxiliary batteries to vehicle batteries.

### For trailers:

Route cable to auxiliary batteries, cut to desired length.

Use cable supplied with trailer kit and route from auxiliary batteries to nose of trailer.

**NOTE: Do not connect cables to any batteries at this time.**

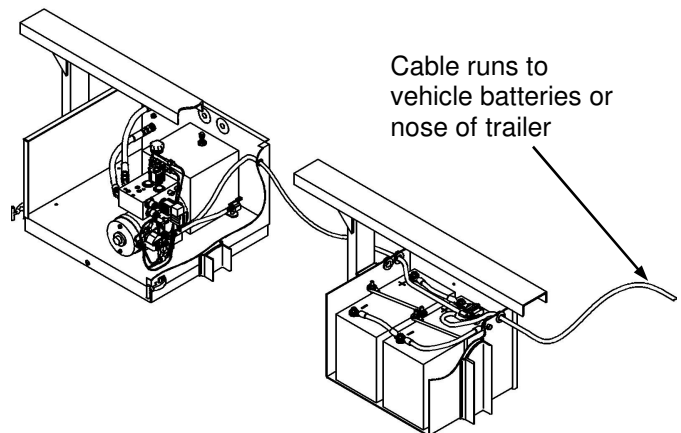

GR01391

# BATTERY KIT INSTALLATIONS

80101387

## INSTALLATION OF TERMINAL LUG

Strip 7/8" to 1" of insulation from end of cable.  
Slide heat shrinkable tubing onto cable.  
Insert bare wire into compression nut until it seats.

**NOTE: Be sure to use correct compression nut, use 2 gauge nut for 2 gauge cable, use 0 gauge nut for 0 gauge cable.**

**Note: Copper wire should be flush with, or slightly past nut**

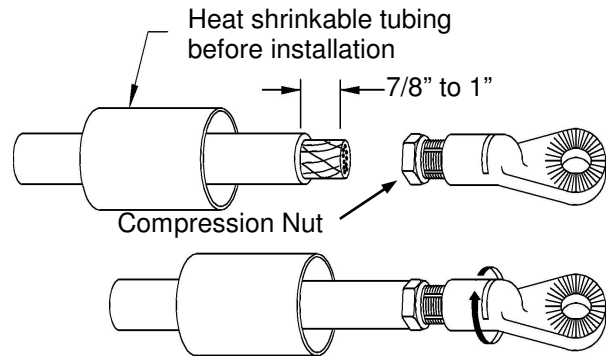

GR00299

Grip nut with wrench and turn terminal until nut seats

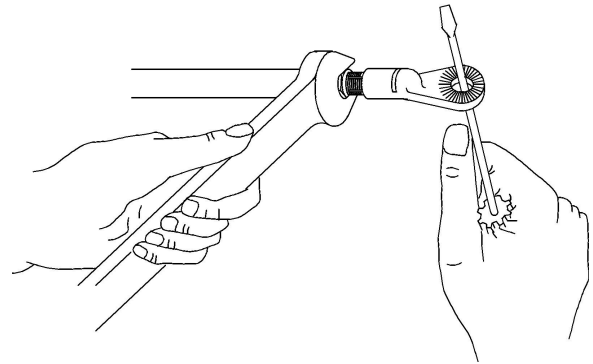

GR00300

Position heat shrinkable tubing over terminal and end of cable

Shrink tubing using electric heat gun or torch.

**Note: To reduce chance of damaging tube and cable, a heat gun is recommended**

Apply sufficient heat to produce thin bead of sealant all around tube edges

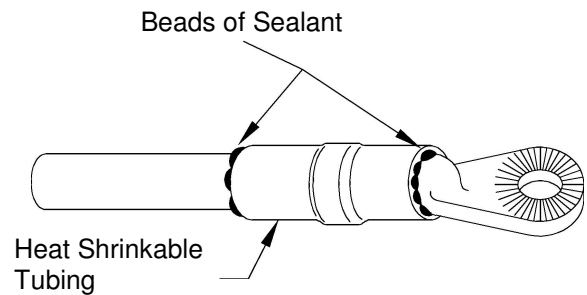

GR00301

# BATTERY KIT INSTALLATIONS

80101387

## INSTALLATION OF SOCKET

Drill 1-3/4" hole in nose of trailer for trailer socket.  
Mount socket to trailer with bolts and nuts provided.  
Attach cable to back of socket with bolt provided.  
Apply a generous amount of Dielectric Grease over cable terminal.

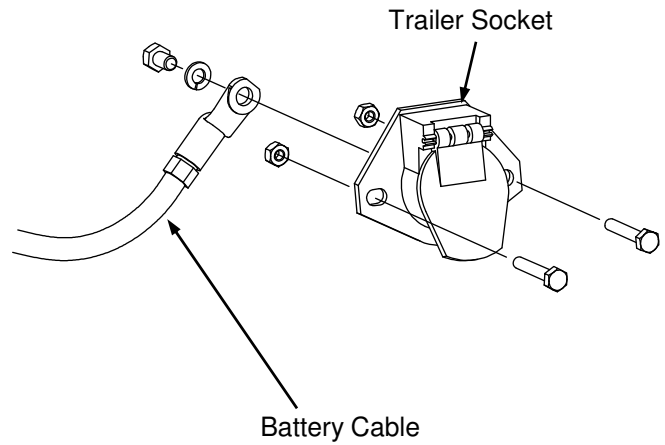

GR02739

Ground trailer socket to main structure of trailer.

Use the 18" ground cable, supplied, and bolt it to the trailer socket and suitable structure on the nose of the trailer.

An angle has been provided, it can be used by welding it to the crash plate, or other suitable structure.

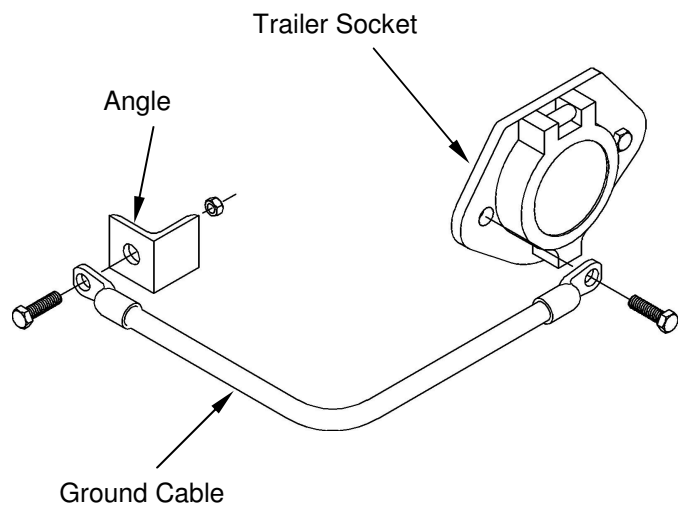

GR01414



# BATTERY KIT INSTALLATIONS

80101387

## INSTALLATION OF CIRCUIT BREAKER(S)

Auxiliary batteries on a truck will require circuit breakers at both the auxiliary batteries and the vehicle batteries.

Locate and mount 150 Amp circuit breaker directly to batteries using copper terminal link supplied.

Circuit breaker must be mounted to give good protection against any objects coming into contact with circuit breaker terminals and causing a short. Position must also be readily accessible to reset breaker.

**Note: Circuit Breaker is to rest solidly on battery to prevent vibration during transit.**

If unable to connect circuit breaker direct to batteries, an optional 24", maximum length, 2 Ga. battery cable may be used.

Connect end of battery cable from liftgate to Terminal Link attached to circuit breaker.

Apply a generous amount of Dielectric Grease to all Positive (Hot) Battery terminals and Circuit Breaker terminals.

Secure all battery cables to chassis frame with cable ties provided.

**NOTE: Original equipment ground cable furnished on vehicle should be at least a number 2 ga. to insure proper operation of pump unit. An auxiliary ground cable should be added between engine block and chassis frame if engine is not adequately grounded to chassis frame. When there are two or more batteries, all cables connecting batteries together must be 2 ga. or heavier. This includes all original equipment batteries on vehicle.**



Protect wires from any sharp edges or holes that may abrade insulated covering of wires.



Secure battery cable so it does not come near, or in contact with, other vehicle wiring, fuel lines, brake lines, air hoses, exhaust system, etc.

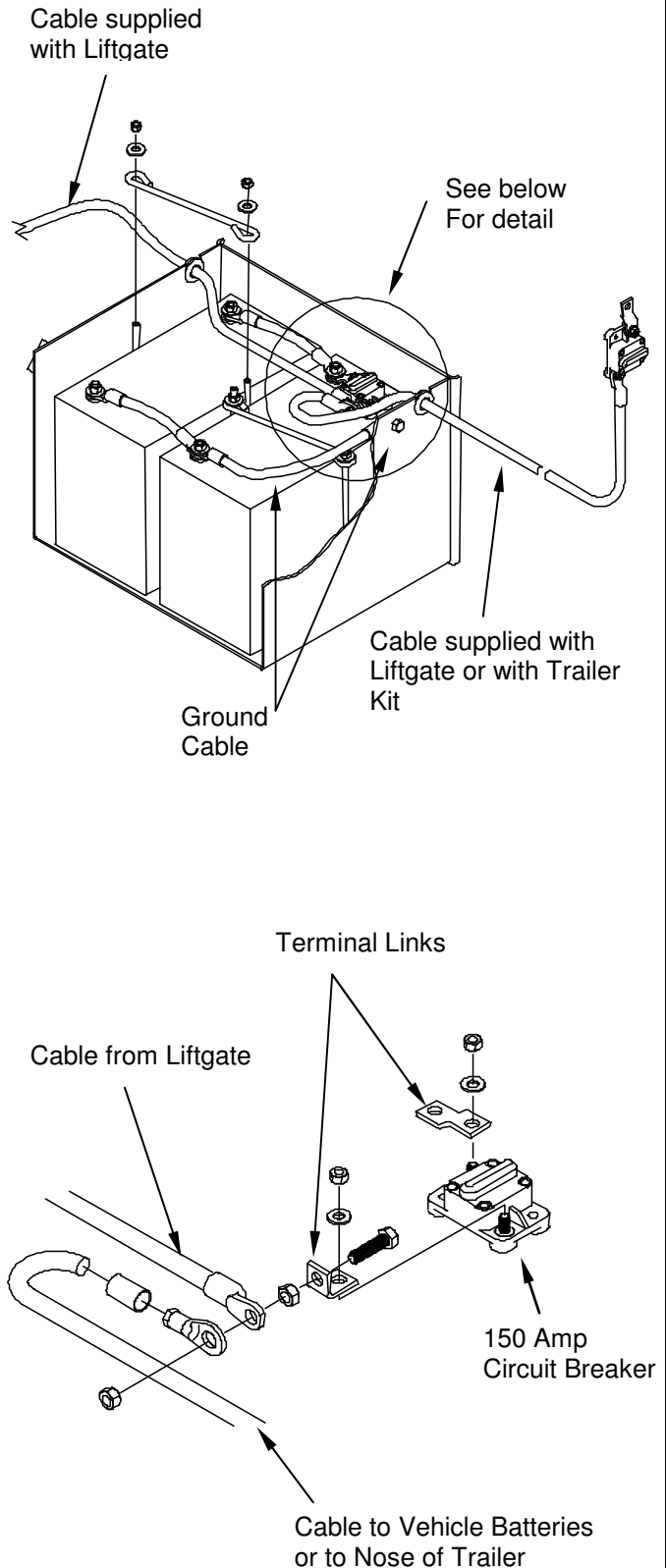

GR01413

# FULL-DOOR SEAL KIT INSTALLATION

- 1. Rubber Air Foil 75089937
- 2. Double Rail 75089936
- 3. Rubber Seal 75089960
- 4. Rail 75089911
- 5. Rubber Sill 75089912

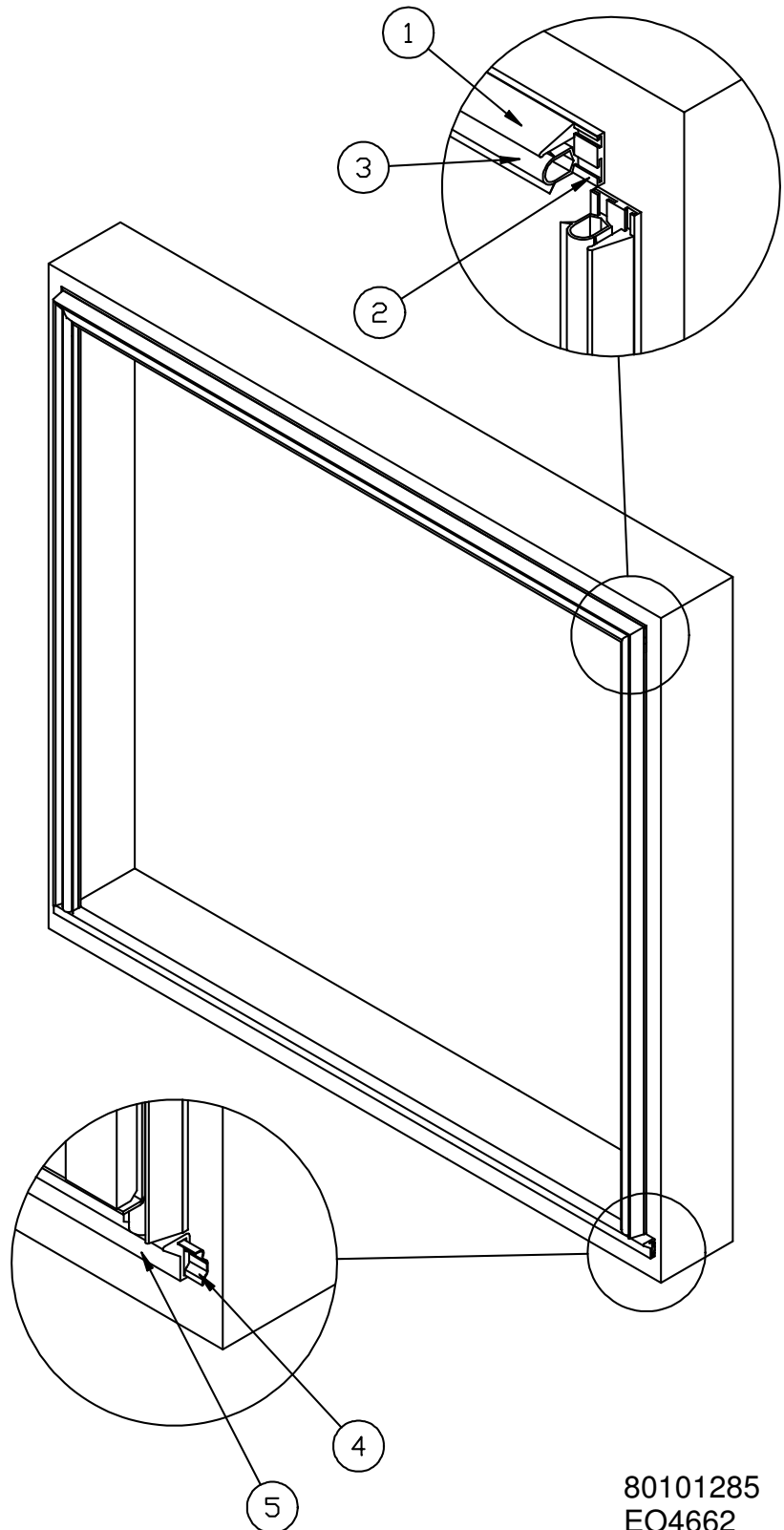

Note: Rubber Seals & Air Foils are cut back in details for clarity

80101285  
EO4662  
Rev 02  
1-2002

# INSTALLATION OF FULL-DOOR SEAL KIT

**Note:** The Side Rubber Seals and Air Foils must be installed on the rear corner posts of vehicle before the Top Seal and Air Foil is installed.

1. With the Platform in the stored position, find the location of the Top Double Rail according to Figure 1. Measure the distance from the vehicle floor to the top of the Top Double Rail and record the measurement as the 'Y' Dimension. Cut the Side Double Rails, Side Rubber Seals, and Side Air Foils to match the 'Y' Dimension.
2. Find the location of the Side Double Rails on the vehicle corner posts. Measure the distance from the outer edge of one Side Double Rail to the outer edge of the other Side Double Rail and record this measurement as the 'X' Dimension. Cut the Top Double Rail, Top Rubber Seal, and Top Air Foil to match the 'X' Dimension. Refer to Step 4 for further instructions on how to position the Side Double Rails.

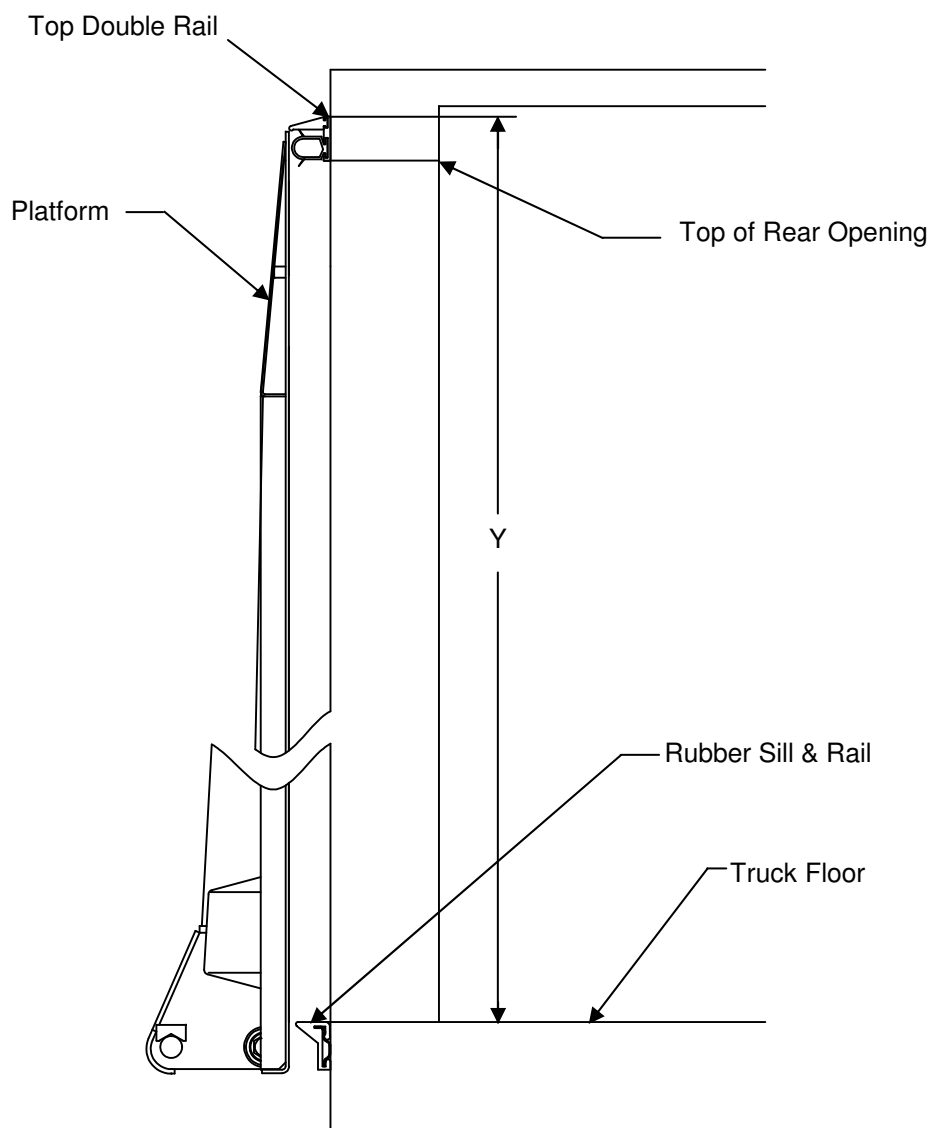

Fig.1

3. Cut the Top & Side Double Rails, Top & Side Rubber Seals, and Top & Side Air Foils at 45° angles as shown.

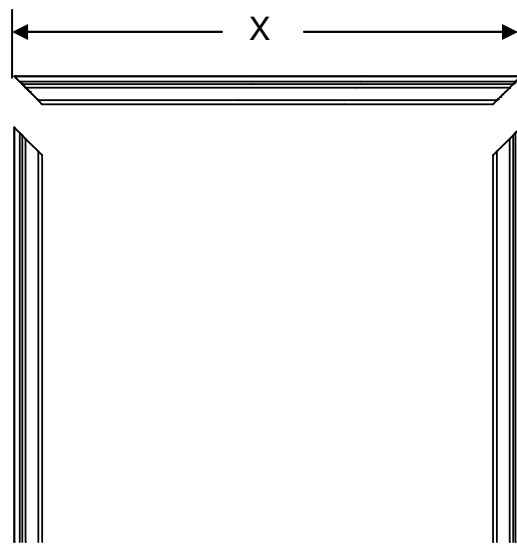

Fig. 2

4. With the Platform open, position the Side Double Rails against the outer side of the Locking Lug as shown below. Use Pop Rivets or Counter-Sunk Screws to attach the Double Rails to the vehicle corner post.

**NOTE:** In some cases the width of the body requires that the Double Rails be notched Around the Locking Lugs due to lack of space.

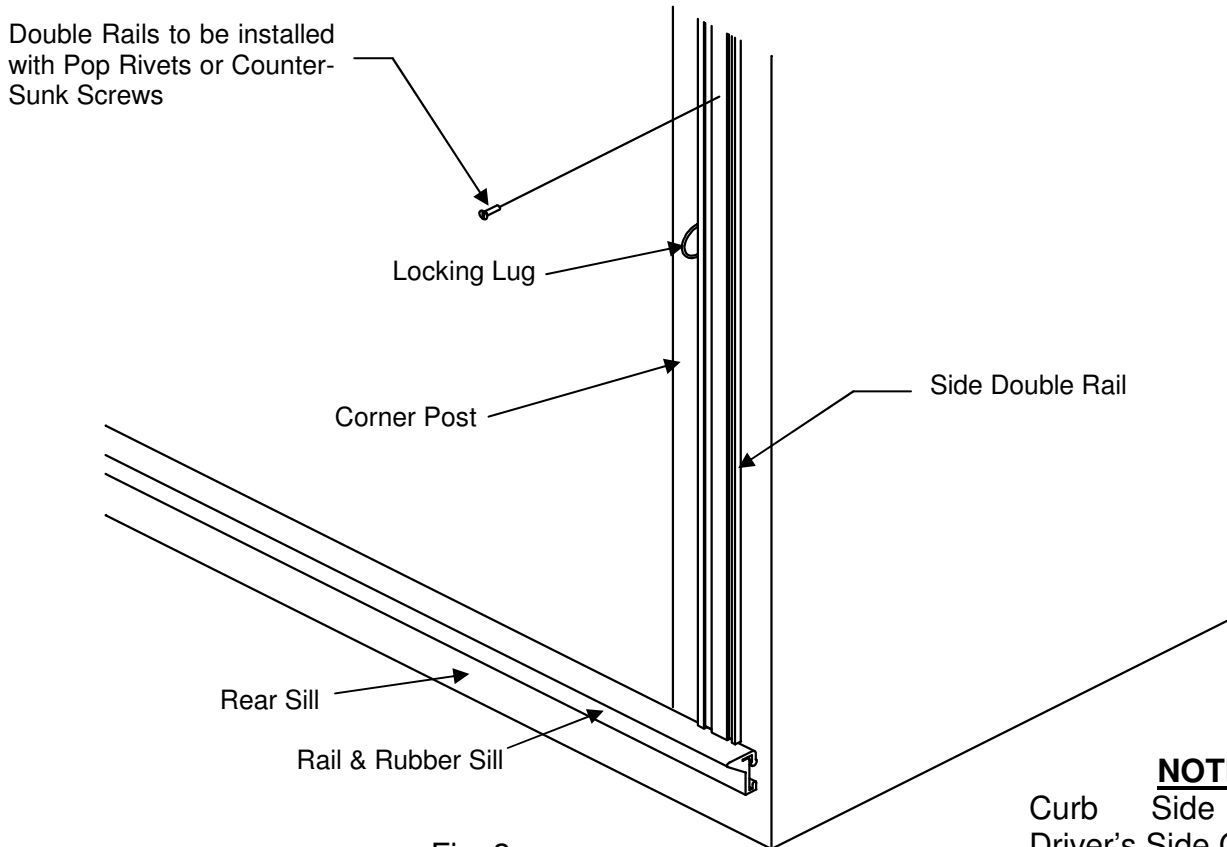

Fig. 3

5. Insert the Rubber Seal & Air Foil down into Side Double Rails from the top as shown.

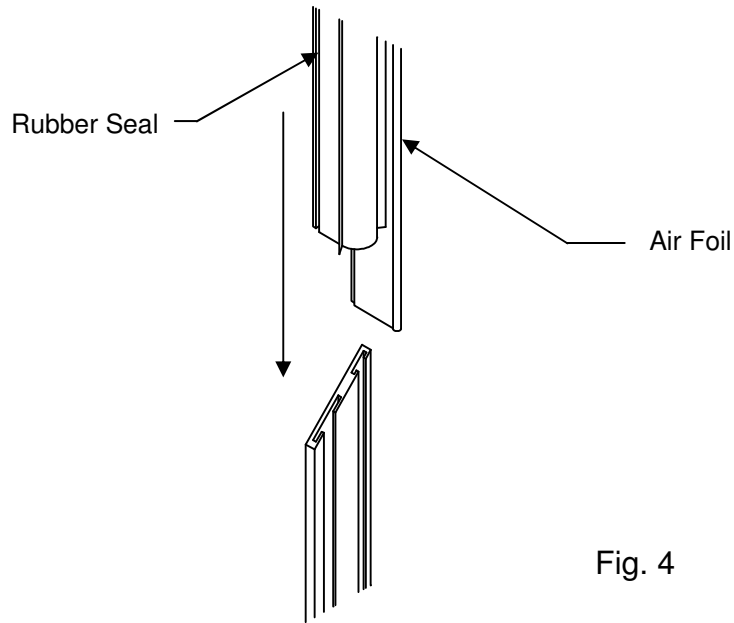

Fig. 4

6. **Before** inserting the Rubber Seal and Air Foil into the Top Double Rail, drill holes in the Top Double Rail and body header. Angled cuts on Top Double Rail and Side Double Rails should make 90° corners as shown.
7. Insert Rubber Seal and Air Foil into Top Double Rail. Use Counter-Sunk Screws or Pop Rivets to attach Top Double Rail to truck body as shown.

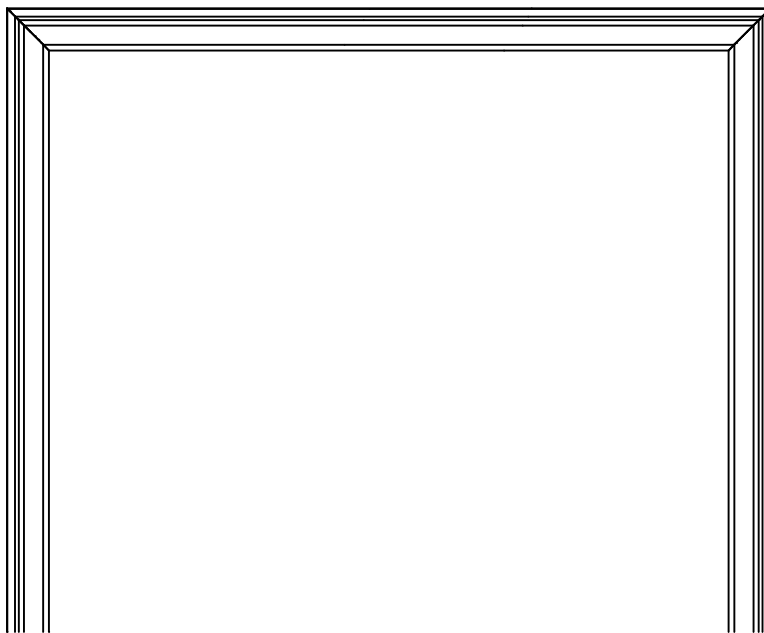
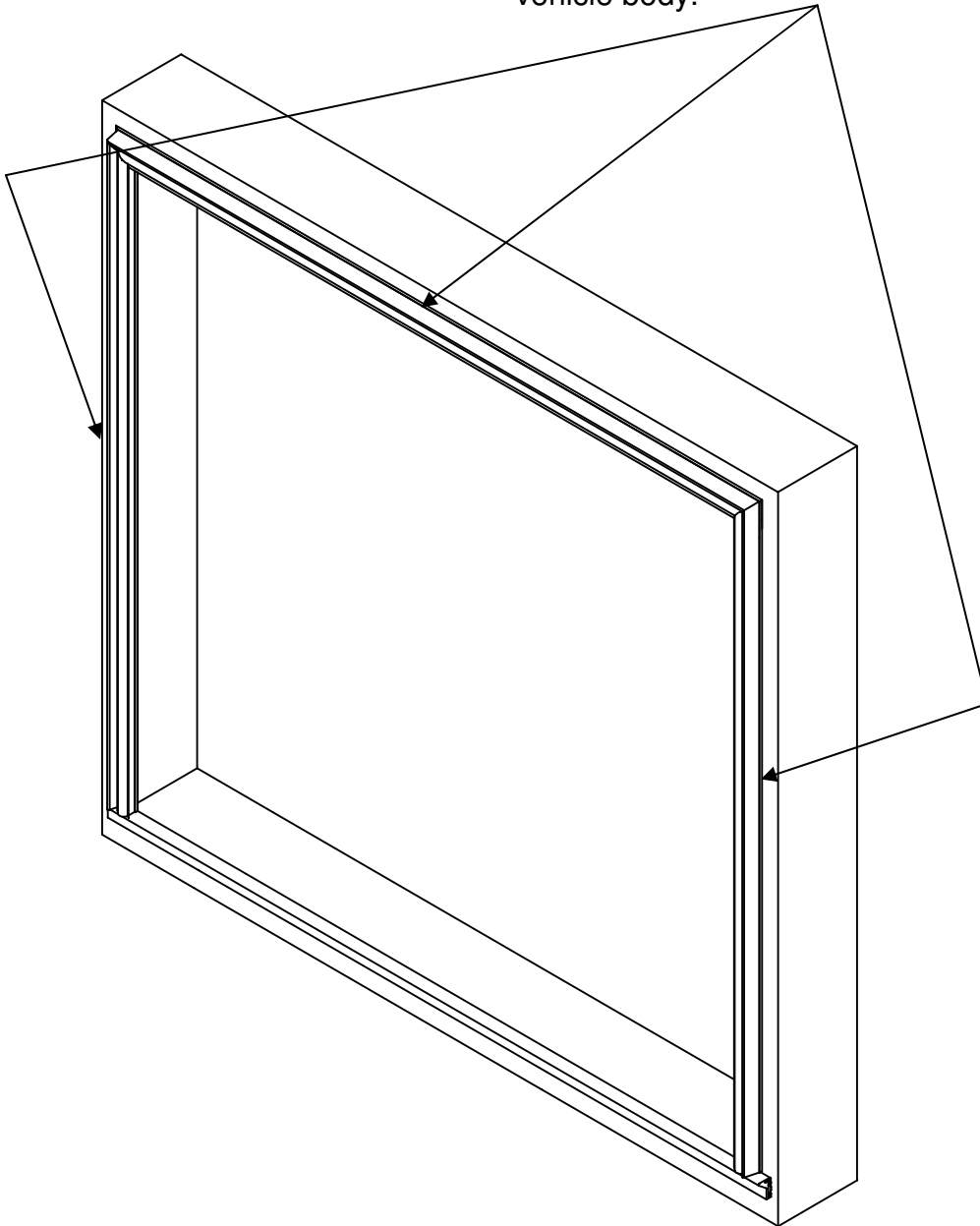

Fig. 5

Add silicone caulk to seal gaps between tracks and vehicle body.



# Cycle Counter Installation Instructions

- **IMPORTANT!** Disconnect battery power supply.
- Review these instructions before beginning. Locate a position on your liftgate for the cycle counter. Be certain that location will not interfere with liftgate operation and is in a relatively protected area. Refer to diagrams shown for suggested locations if required.
- Make certain wires will reach connections on pump unit.
- See below for hole size and pattern required for mounting counter, if required.
- Locate and drill two mounting holes as shown, if not already present. Take necessary precautions to prevent metal shavings from contaminating the hydraulic system.
- Mount cycle counter bracket using two #6-32 screws and lock nuts.
- Connect ground wire of cycle counter to ground stud.
- Connect red wire from cycle counter to wire adapter, and connect other ends of wire Adapter between lowering valve coil and control switch wire.  
FOR WDV: Connect red wire from cycle counter to wire adapter, and connect ring terminal end of wire adapter to S3 valve.
- Loosely bundle and wire tie slack wires as needed.
- Re-connect battery power supply and operate liftgate to test.

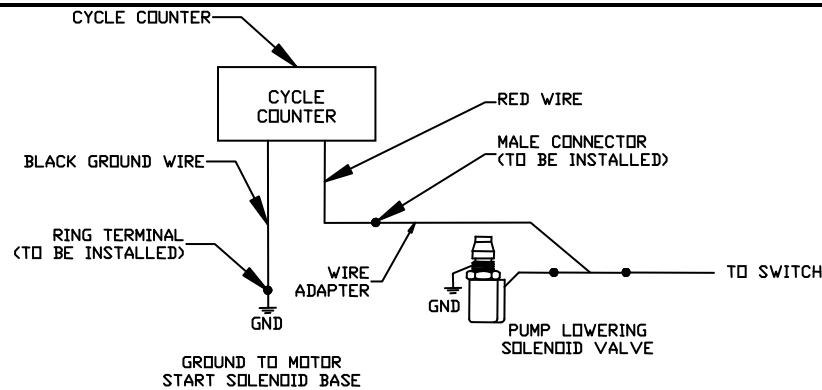

GR02891

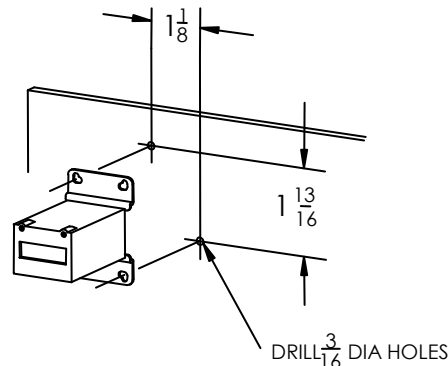

GR02824

EO7804

80101564 12/15 Rev 03

# How To Order Parts

**Repairs should be made only by authorized mechanics using WALTCO Replacement parts.**

When ordering repair or replacement parts, please include all the information asked for below. If this information is not available, a complete written description or sketch of the required part will help WALTCO identify and deliver the needed part to you.

---

## THE FOLLOWING INFORMATION MUST BE INCLUDED:

1. SERIAL NUMBER - [WALTCO liftgate serial numbers can be found on the Specification Tag attached to the mount frame. (On older units the Specification Tag is located on the side or bottom of the platform.)]
2. MODEL NUMBER - [Or capacity]
3. PLATFORM SIZE

---

## THEN INCLUDE THE FOLLOWING INFORMATION:

4. PART NUMBERS
5. DESCRIPTION
6. QUANTITY REQUIRED

---

## MAIL, E-MAIL OR PHONE YOUR REQUEST TO:

Waltco Lift Corp  
285 Northeast Avenue  
Tallmadge, OH 44278  
1-800-411-5685  
FAX: 1-800-411-5684  
E-MAIL: parts@waltco.com

**ALL PARTS ARE F.O.B. FROM THE SHIPPING FACTORY**

---

## PLEASE NOTE:

**To assure you of continuing and effective quality control, our warranty policy permits replacement of hydraulic cylinders, valves and motor pump units when their factory seals are intact. Parts under warranty will be exchanged promptly after careful inspection of the returned assemblies.**

---





**Every vehicle that has a WALTCO Liftgate must have legible WARNING AND OPERATION DECALS clearly posted on the vehicle and an OWNER'S MANUAL in the vehicle at all times as a guide for proper operation and maintenance.**

Additional WARNING DECALS, OPERATION DECALS and OWNER'S MANUALS can be obtained from WALTCO LIFT CORP.

---

**NOTE:**

**When ordering, give model  
and serial number of the liftgate.**

---

This page left intentionally blank.

# ***IMPORTANT***

## **WARNING**

**Improper operation and maintenance of this liftgate could result in severe personal injury or death.**

**Read and understand the contents of this manual and all warning and operation decals before operating and/or performing maintenance on this liftgate.**

**For SAFETY information on this liftgate see Chapter 1 of this manual**