

LOGLIFT 140S



LOGLIFT 140S BASISDATEN

Technische Daten	F140S 79	F140S 79 BOOSTER	F140S 96
Max. Hubkapazität (kNm)	136	160	129
Hydraulische Reichweite* (m)	7,90	7,90	9,63
Hydraulische Armverlängerung* (m)	1,59	1,59	3,20
Reichweite - Hubkapazität, Standard (m - kg)	3,0 - 4200 4,0 - 3250 5,0 - 2650 6,0 - 2260 7,0 - 1940 7,9 - 1640	3,0 - 4500 4,0 - 3850 5,0 - 3150 6,0 - 2650 7,0 - 2280 7,9 - 1940	3,0 - 3650 4,0 - 3100 5,0 - 2550 6,0 - 2160 7,0 - 1840 8,0 - 1600 9,0 - 1400 9,6 - 1260
Schwenksystem	Doppelt	Doppelt	Doppelt
Schwenkwinkel (°)	425	425	425
Schwenkmoment, brutto (kNm)	32,1	32,1	32,1
Max. Neigung bei voller Kapazität (°)	8	8	8
Max. Arbeitsdruck (MPa) ¹⁾	26	30	26
Empfohlener Öldurchfluss – Konstantpumpe (l/min), 1 Pumpe	80	80	80
Empfohlener Öldurchfluss – Konstantpumpe (l/min), 2 Pumpe	2 x 80	2 x 80	2 x 80
Min. empfohlener Öldurchfluss – Verstellpumpe (l/min)	160	-	160
Erforderliche Leistung bei empf. Ölfluss (kW) - Konstantpumpe, 1 Pumpen	39	44	39
Erforderliche Leistung bei empf. Ölfluss (kW) - Konstantpumpe, 2 Pumpen	77	89	77
Erforderliche Leistung bei empf. Ölfluss (kW) - Verstellpumpe	77	-	77
Aufbaubreite (mm)	2500	2500	2500
Gewicht - Hochsitzkran mit ET370-Stützbeinausrüstung (kg) ²⁾	2180		2300

¹⁾ Druckboosteroption für vorübergehende Nutzung möglich, detaillierte Informationen auf Anfrage verfügbar

²⁾ Gewicht mit Konstantpumpensystem, inklusive Ölgewicht

Lastdiagramm F140S 79

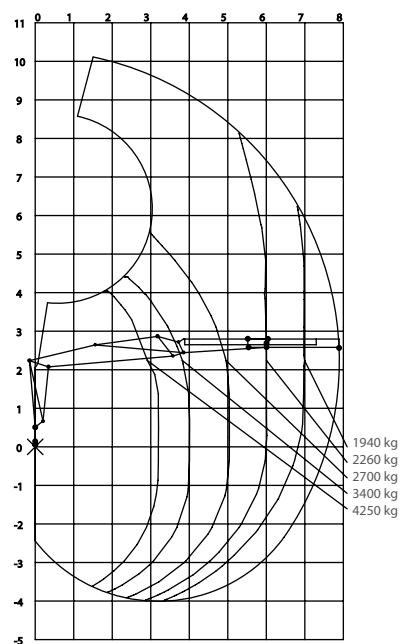

Lastdiagramm F140S 96

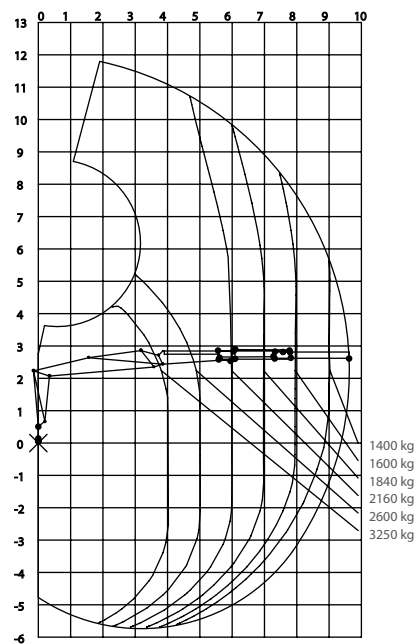

Lastdiagramm F140S 96i

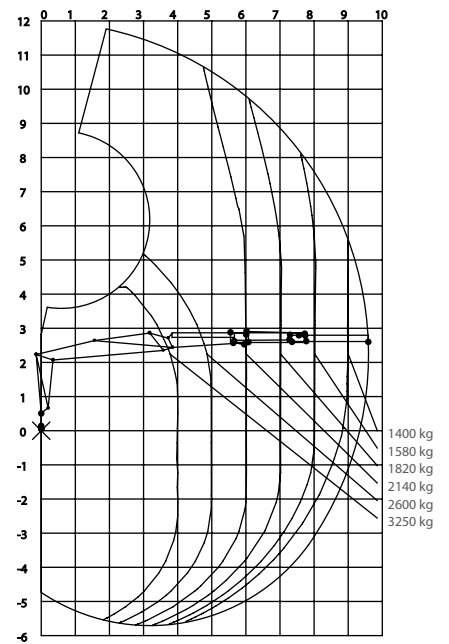

F140S 96 BOOSTER	F140S 96i	F140S 96i BOOSTER
154	129	154
9,63	9,60	9,60
3,20	3,15	3,15
3,0 - 4000 4,0 - 3700 5,0 - 3050 6,0 - 2550 7,0 - 2180 8,0 - 1900 9,0 - 1680 9,6 - 1520	3,0 - 3650 4,0 - 3100 5,0 - 2550 6,0 - 2140 7,0 - 1820 8,0 - 1580 9,0 - 1400 9,6 - 1250	3,0 - 4000 4,0 - 3650 5,0 - 3000 6,0 - 2550 7,0 - 2180 8,0 - 1900 9,0 - 1680 9,6 - 1500
Doppelt	Doppelt	Doppelt
425	425	425
32,1	32,1	32,1
8	8	8
30	26	30
80	80	80
2 x 80	2 x 80	2 x 80
-	160	-
44	39	44
89	77	89
-	77	-
2500	2500	2500
	2320	

Lastdiagramm F140S 79 BOOSTER

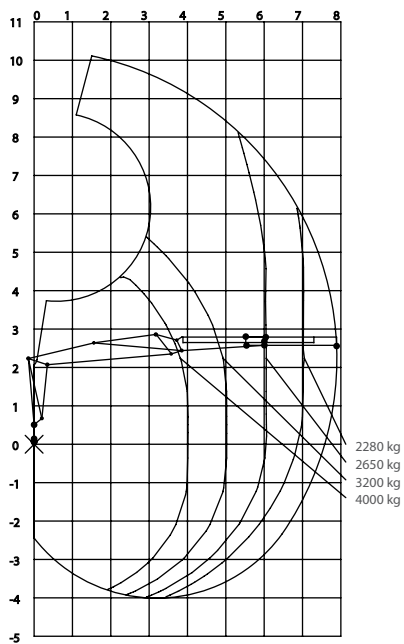

Lastdiagramm F140S 96 BOOSTER

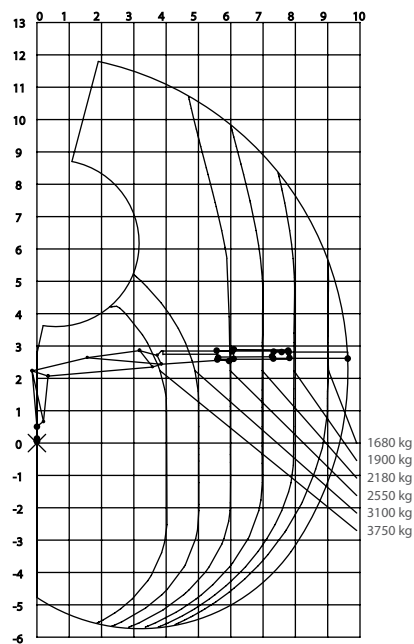

Lastdiagramm F140S 96i BOOSTER

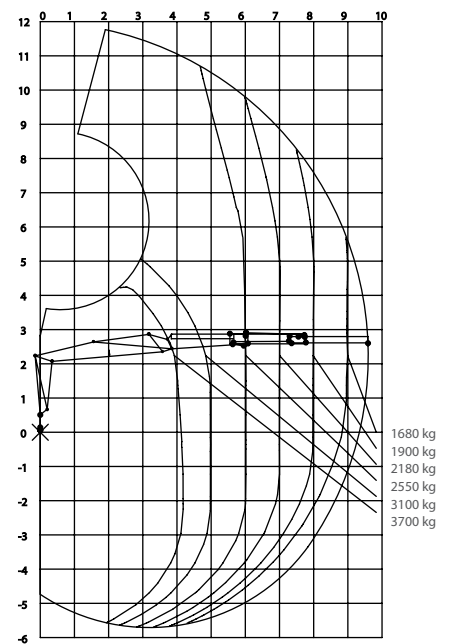

F140S Kabine

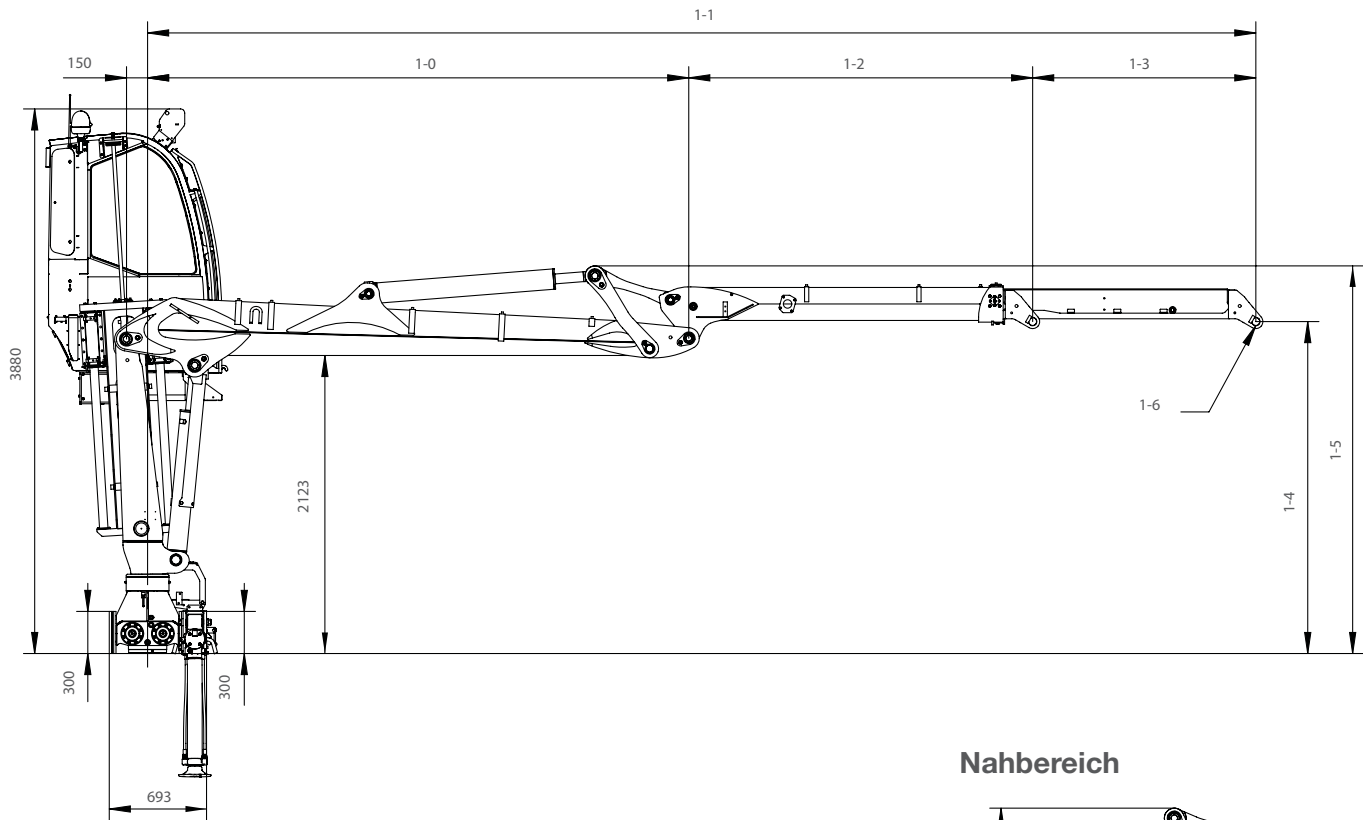

Nahbereich

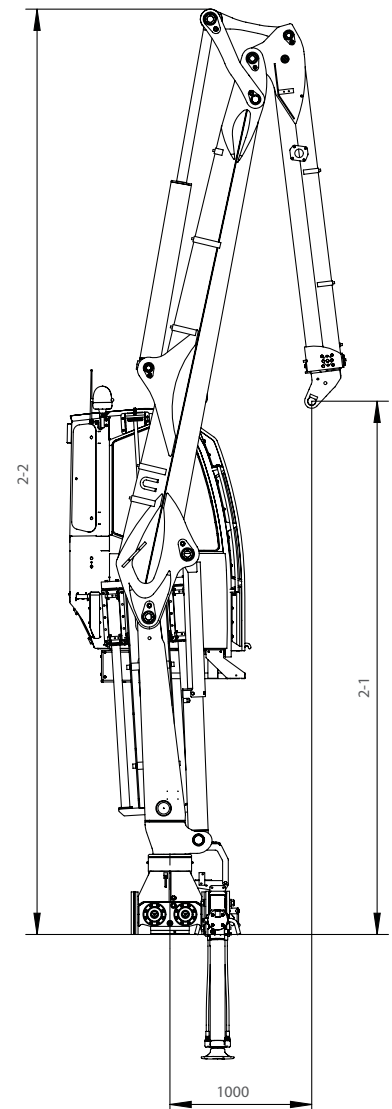

Modell	1-0	1-1 min	1-1 max	1-2	1-3	1-4	1-5	1-6
79i	3855	6305	7895	2450	1590	2365	2761	Ø 40, B=184
79i	3855	6355	7945	2500	1590	2379	2761	Ø 40, B=184
96	3855	6425	9625	2570	3200	2410	2857	Ø 45, B=80
96i	3855	6445	9595	2590	3150	2398	2761	Ø 40, B=184
96i	3855	6495	9645	2640	3150	2416	2761	Ø 40, B=184

Modell	2-1	2-2	HPL	HPL Nordic
79i	3761	6526	X	
79i	3709	6526		X
96	3638	6529		
96i	3617	6529	X	
96i	3566	6528		X

F140S Kabine geparkt

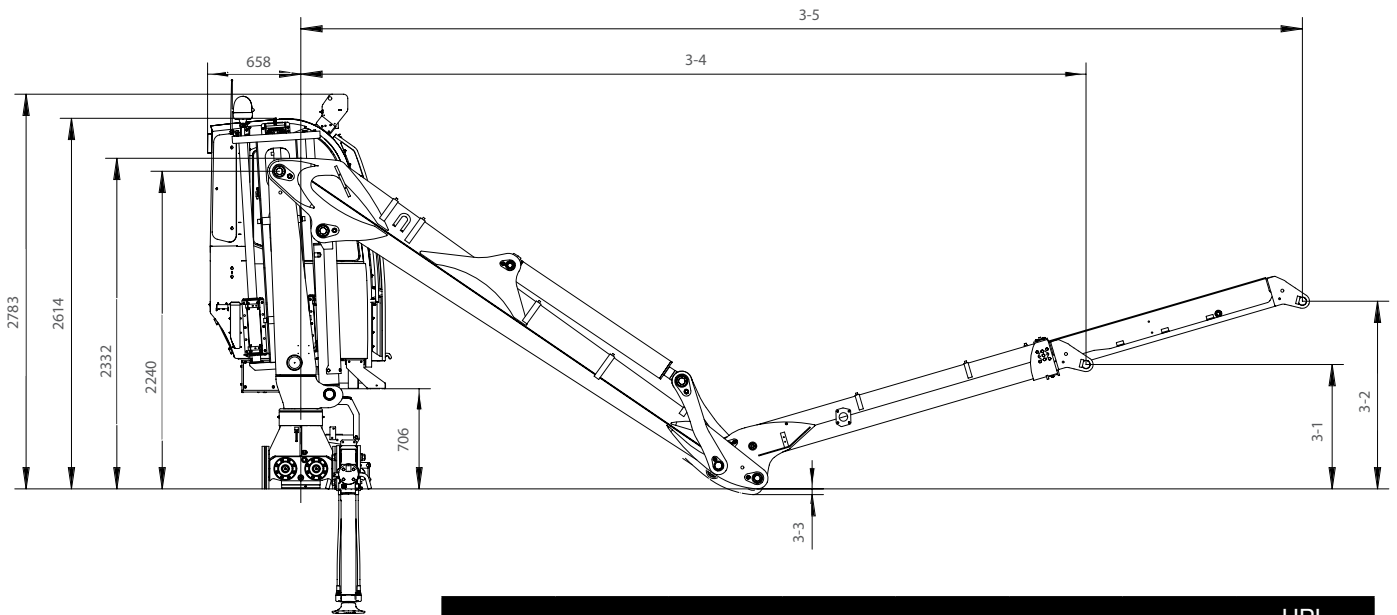

Modell	3-1	3-2	3-3	3-4	3-5	HPL	HPL Nordic
79i	877	1323	40	5538	7064	X	
79i	920	1366	40	5578	7104		X
96	951	1492	40	5641	7500		
96i	946	1482	40	5664	7500	X	
96i	977	1499	40	5707	7500		X

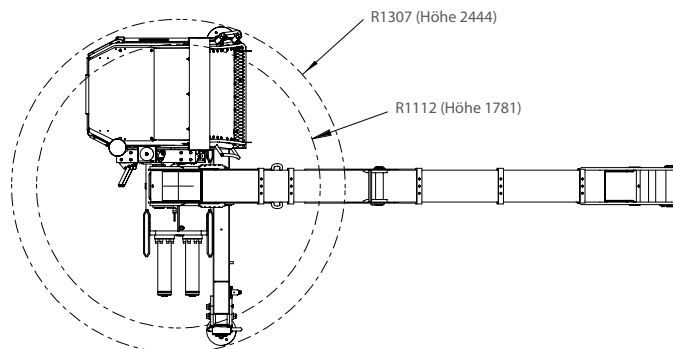
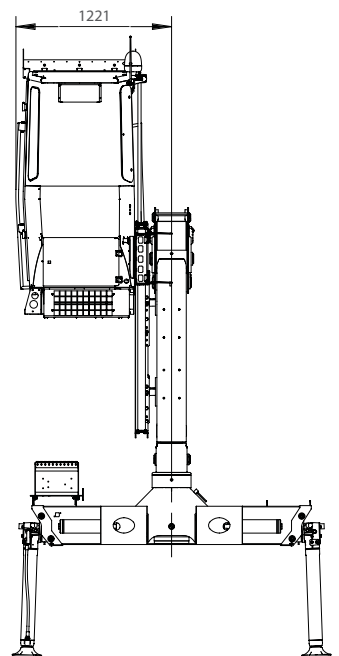
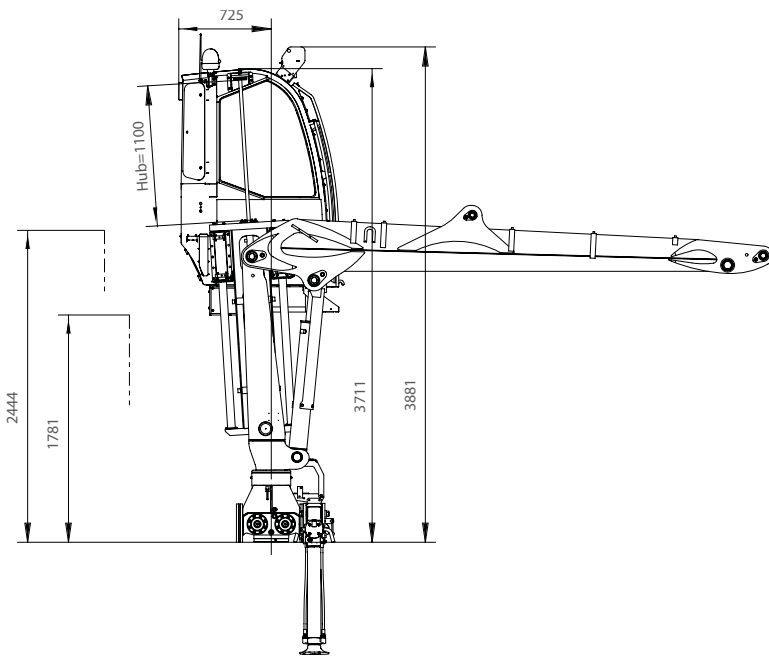

F140S Hochsitz

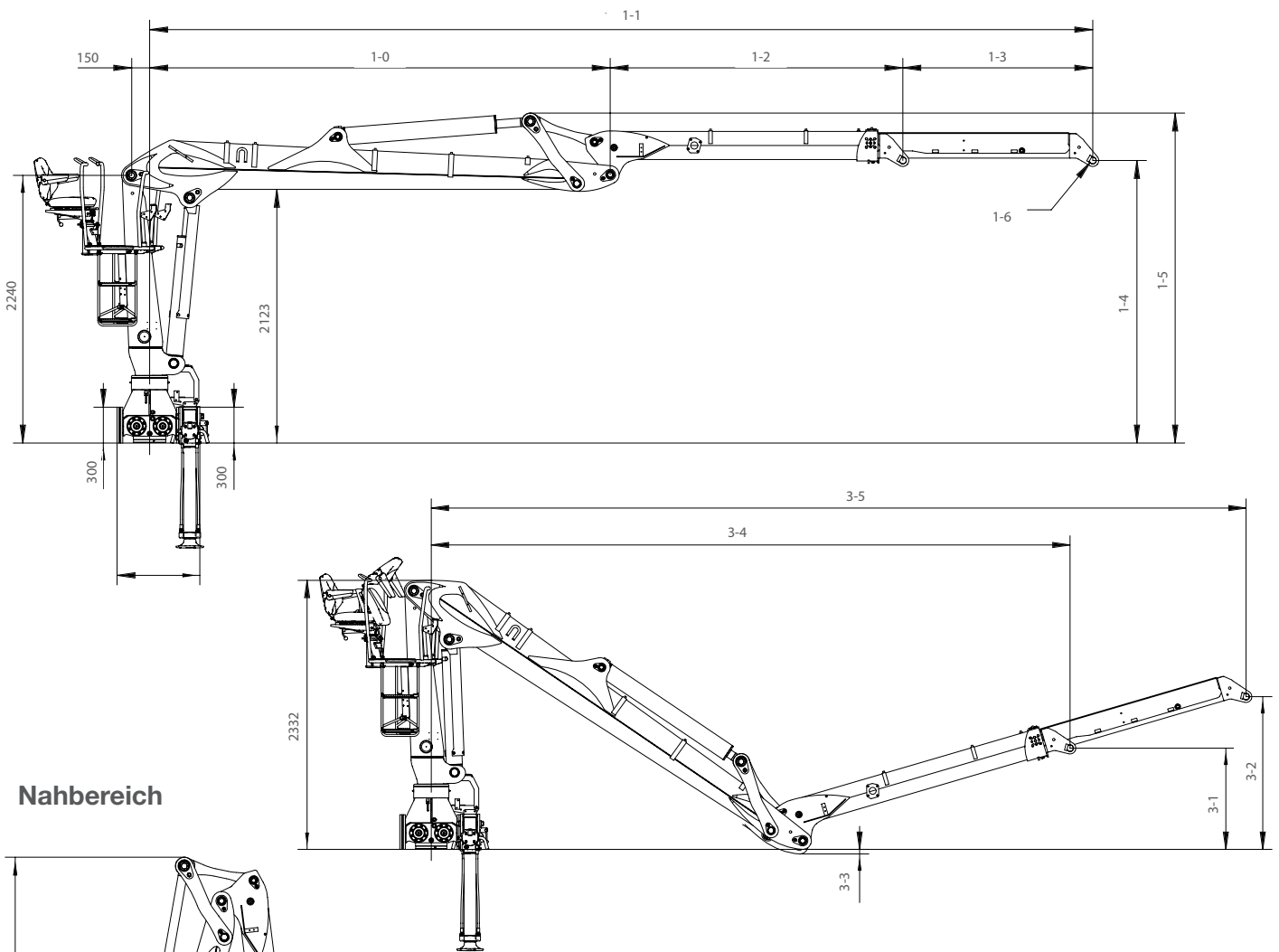

Nahbereich

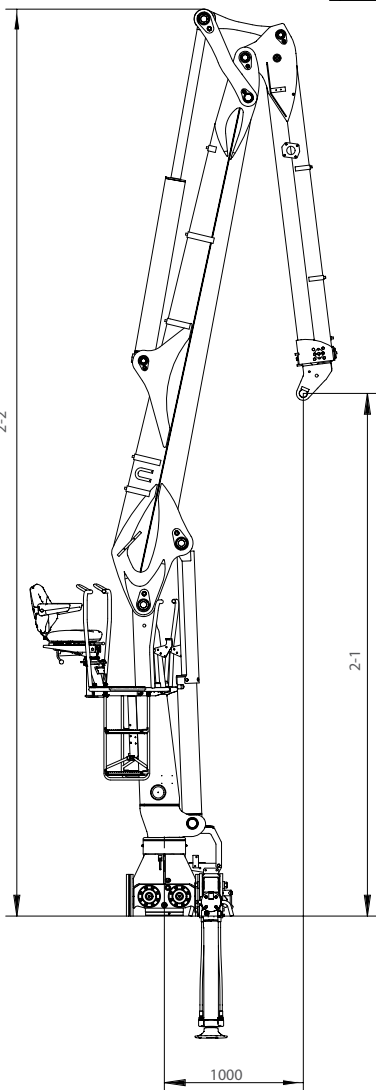

Modell	1-0	1-1 min	1-1 max	1-2	1-3	1-4	1-5	1-6
79i	3855	6305	7895	2450	1590	2365	2761	Ø 40, B=184
79i	3855	6355	7945	2500	1590	2379	2761	Ø 40, B=184
96	3855	6425	9625	2570	3200	2410	2857	Ø 45, B=80
96i	3855	6445	9595	2590	3150	2398	2761	Ø 40, B=184
96i	3855	6495	9645	2640	3150	2416	2761	Ø 40, B=184

Modell	2-1	2-2	HPL	HPL Nordic
79i	3761	6526	X	
79i	3709	6526		X
96	3638	6529		
96i	3617	6529	X	
96i	3566	6528		X

Modell	3-1	3-2	3-3	3-4	3-5
79i	877	1323	40	5538	7064
79i	920	1366	40	5578	7104
96	951	1492	40	5641	7500
96i	946	1482	40	5664	7500
96i	977	1499	40	5707	7500

Hochsitz

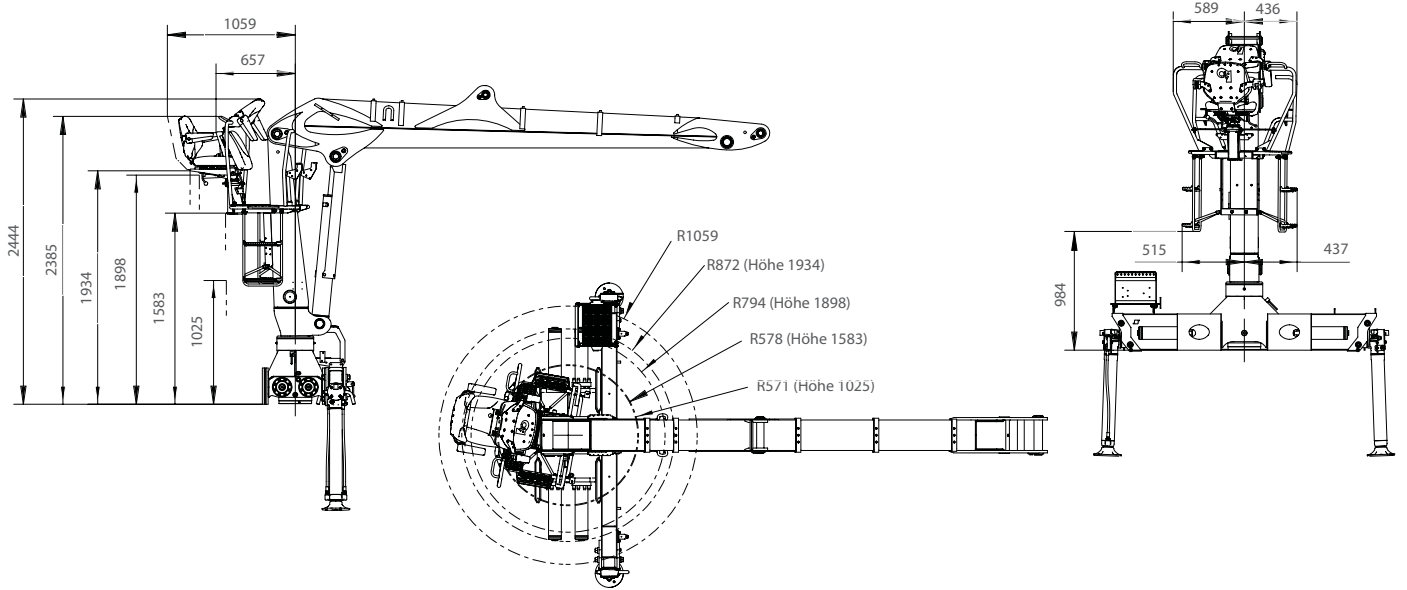

Hubarm (Kabine)

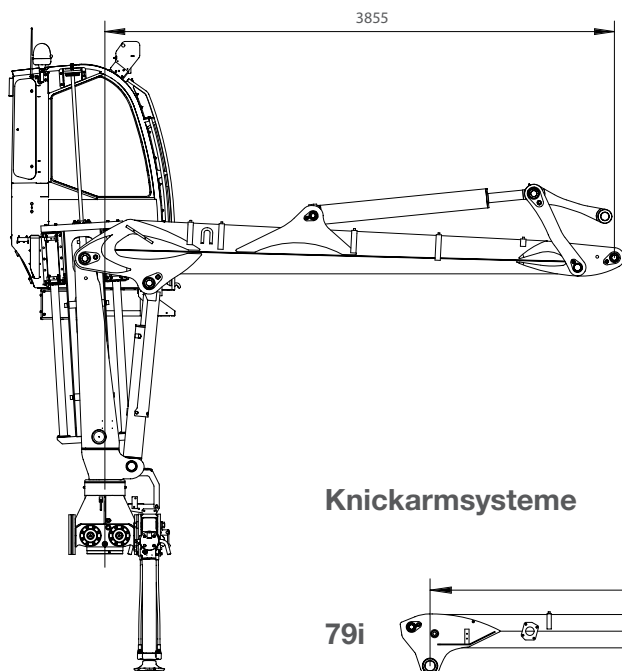

Hubarm (Hochsitz)

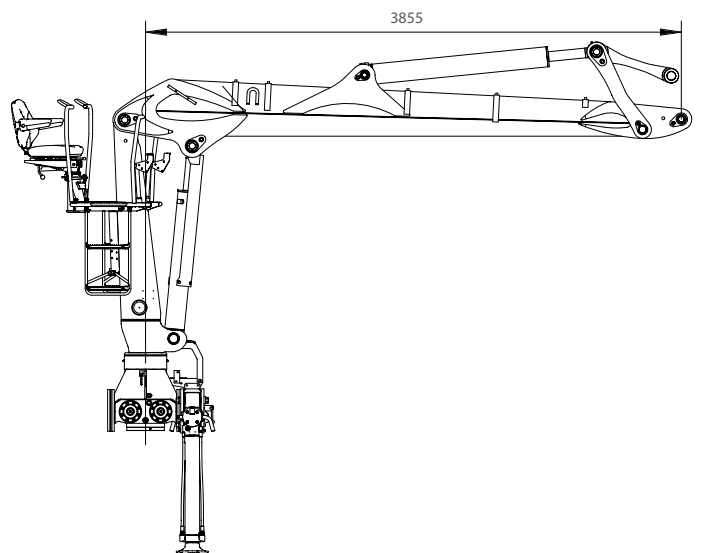

Knickarmsysteme

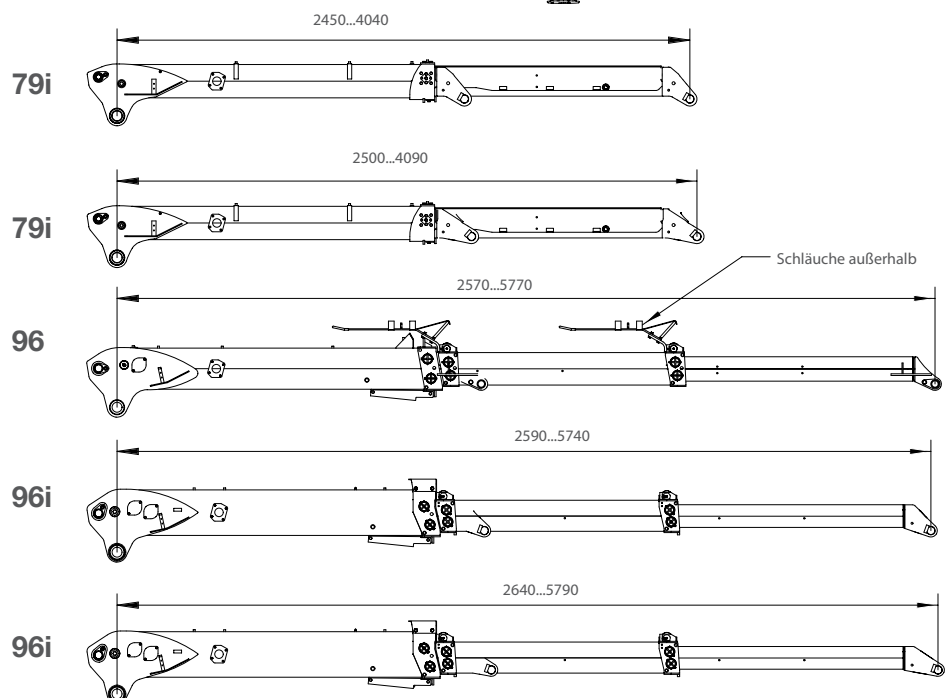

Stützbeine ET370

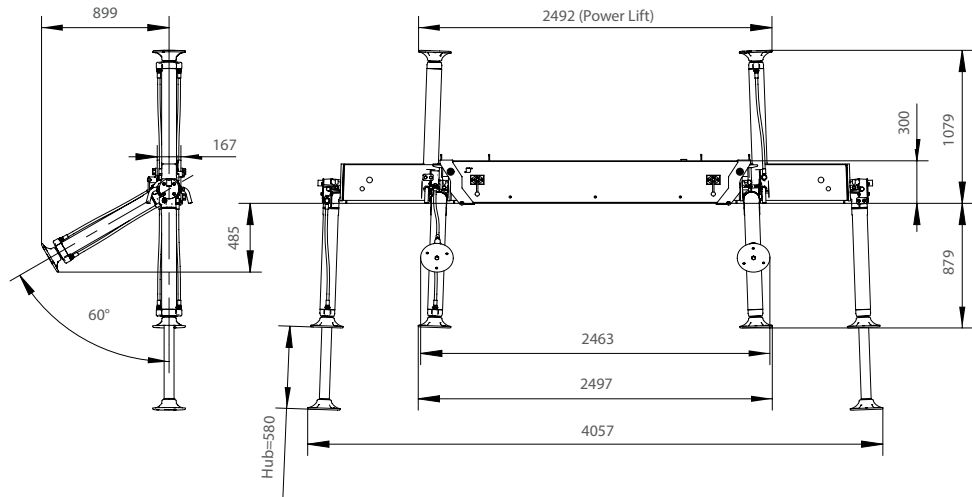

Basis mit Stützbeinen ET370

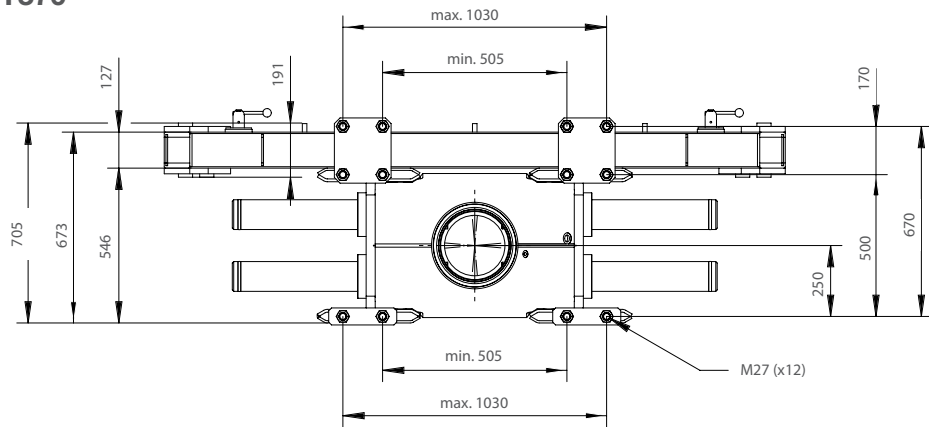

Stützbeine B4820

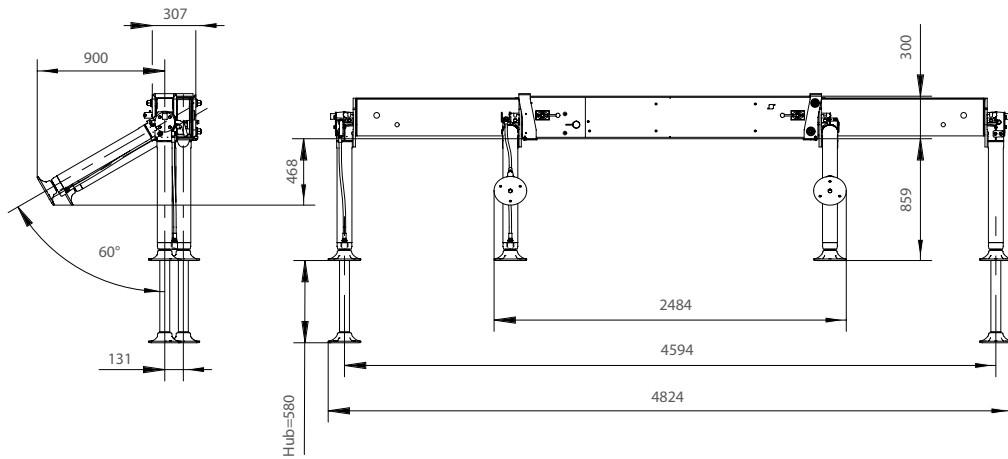

Basis mit Stützbeinen B4820

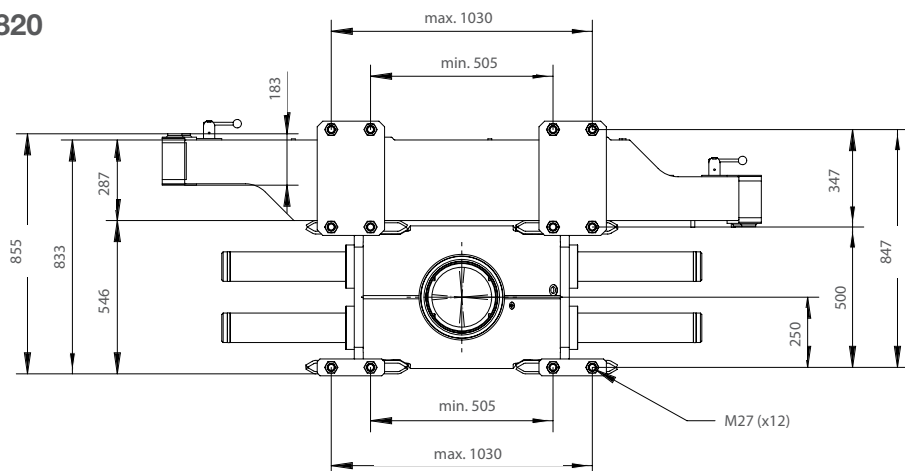

BUILT TO PERFORM

Hiab ist der weltweit führende Anbieter von Geräten für den Ladungsumschlag auf der Straße. Kundenzufriedenheit ist unsere oberste Priorität. Zum Hiab-Produktsortiment gehören HIAB-Ladekrane, JONSERED-Forst- und Recyclingkrane, LOGLIFT-Forstkrane, MOFFETT-Mitnehmstapler, MULTILIFT-Wechselgeräte sowie Ladebordwände der Marken DEL, WALTCO und ZEPRO.

hiab.com

Hiab ist ein Teil von Cargotec.

cargotec.com

Haftungsausschluss. Wir behalten uns das Recht auf Änderungen vor. Abbildungen, Zeichnungen und Daten entsprechen nicht immer der aktuellsten Version oder dem Standardmodell in der Produktion. Die Modelle in den Abbildungen können Sonderausstattung oder Sonderfarben darstellen.

© TD-F140S-DE-WW_170829

