

Installation Manual

WHZ 1300 lb. Capacity

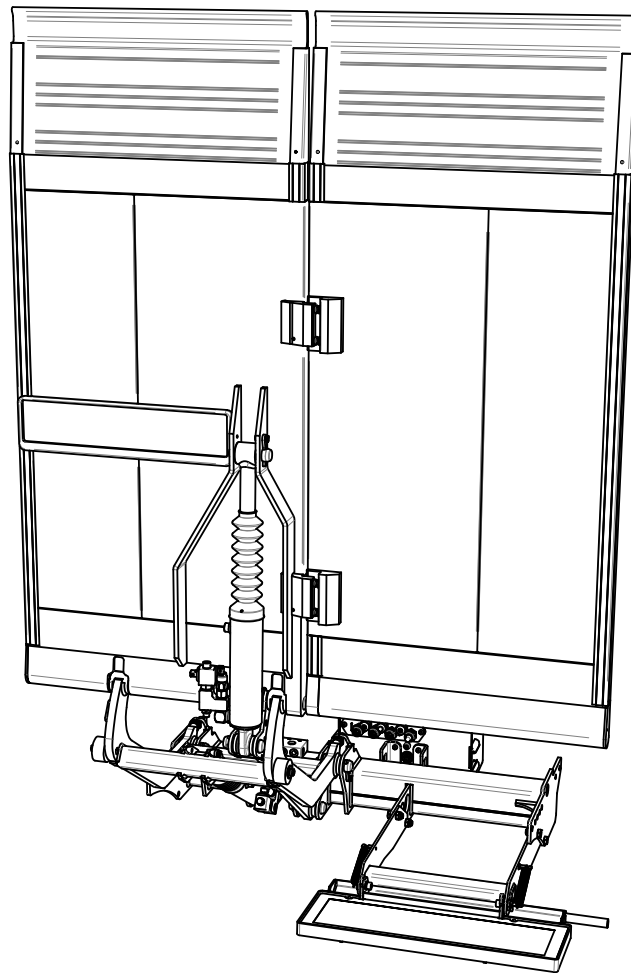

Contents	Page
1. CE marking.....	4
2. General	5
3. Dimensions for installation	9
4. Introduction.....	10
5. Mounting kits	11
6. Electrical installation.....	22
7. Electric and hydraulic diagram	23
8. Installation, miscellaneous.....	26
9. Important information	28
10. Markings, positioning of decals on lift.....	29
11. Testing the lift	31
12. Dismantling	33
13. How to Order Parts.....	34

1. CE marking



Since 1/1/1995 ZEPRO tail lifts sold to the European market are stamped with a CE mark. This is the manufacturer's guarantee that the product conforms to the European Machinery Directive. Waltco stands behind this guarantee.

The application of the European Machinery Directive is intended to harmonise product safety levels across Europe.

There are some general principals that should be made clear when performing the installation of ZEPRO/Waltco lifts.

Follow the installation instructions. If it is not possible to follow the installation instructions or if modifications are required (mechanical), the modifications must be approved by the manufacturer.

Note! Electric and hydraulic modifications is not allowed! This is a consequence of the CE marking regulations as it cannot be possible for a manufacturer to certify conformity to the Machinery Directive if the product is subsequently changed without his knowledge or approval. In order for the product's CE marking to remain applicable the forms supplied by ZEPRO/Waltco must be completed in case of modification.

Welding is **not necessary** unless specifically recommended by the manufacturer.

In order to increase security, additional decals, which are diagrammatic and easily understood independent of language will be sent with the lifts.

Ensure that these decals are affixed so that the information contained on them is available for all users of the lift.

Position the control unit to ensure that the operator has a good view of the load, the working area and the loading area, whilst maintaining a safe distance from the risk zone between the platform and the body. Follow the operator's instructions for use of the control unit and its functions.

2. General

Technical description

The ZEPRO/Waltco-lift is electro-hydraulically driven. An electric motor which gets its power from the truck's ordinary battery drives a hydraulic pump which supplies oil via hoses and pipes to the working hydraulic cylinders. The system is steered by electrical valves.

The hydraulic power unit with all details is built into a separate box. The system is easy to reach for service and maintenance.

The platform is supported by the lift arm which is very strong and rigid. The platform has a non-slip surface. Lift cylinders provide the mechanical force to control the lift arm's movement. The cylinders are equipped with electric safety valves which prevent platform movement if a hose breaks. These valves are closed unless opened by current supplied from the hydraulic unit when the control unit down button is pressed. The tilt function is controlled by a double acting cylinder which is also equipped with an electric safety valve. Electric safety valves also provide a transport lock for the platform to both prevent downwards and outwards movement of the platform. Lifting and tilting up and down speeds are fixed by the pump capacity. Lowering speed are controlled by a special constant flow valve. These valve give the same speed independent of the load.

The cylinder piston rods are treated with carbon nitriding which gives them very long life.

The hydraulic system is protected with a pressure regulator when lifting or tilting up.

Note! This regulator does not prevent overload at rest position or lowering.

The electric power is taken from the truck's ordinary starter motor. Control current is taken from the dash board. When the control current's isolator (cabin) switch is off, the lift is "locked". Fixed control units are electrically heated to prevent condensation damage to switches.

To save current the control current should be switched off when the lift is not used.

The lift can also be operated from other, optional units.

To ensure safe operation even with very long control cables, the hydraulic unit is equipped with relays.

The relays situated in the electrical connection box placed in the support frame steer current directly from the main cable to the valves and the main switch for the motor.

The electric motor is equipped with a thermostat which breaks the current if the motor becomes overheated. The motor will stop until it is cool again.

The platform can be tilted to all positions from vertical to 13° below the horizontal. It has a mechanical or electric lock which must be activate during transport.

Hydraulic oil

A liftgate should operate just as well in tropical as in arctic climates. Heat does not adversely effect the hydraulic oil, however, low temperatures are more critical. WALTCO therefore supplies a hydraulic oil that meets the demands across the temperature range. ZEPRO oil (art.no 21963 for 1 litre) is made of a highly refined mineral oil, the lubricant additive is free from zinc and gives good protection against component wear. The hydraulic oil's low temperature properties and high viscosity index allow hydraulic system start in a very cold climate and give reliable functioning with varying temperature conditions. With ZEPRO oil the hydraulic system also receives a very good protection against corrosion.

ZEPRO also has a biologically degradable oil (art. no 22235 for 1 litre) available which is based on a synthetic base oil. This also provides very good properties at low and high temperatures. It is even liquid down to -50°C. Resistance to oxidation is extremely good which gives long lifetime with longer intervals between oil changes. Good filtration and air separation together with low density make the oil easy to pump. This minimizes risk for cavitation and development of scum. Contact us for more information.

NB. Neither ATF nor HF oil should be used in the ZEPRO hydraulic circuit as they can damage the rubber in the sealing kits and reduce their lifetime.

2. General

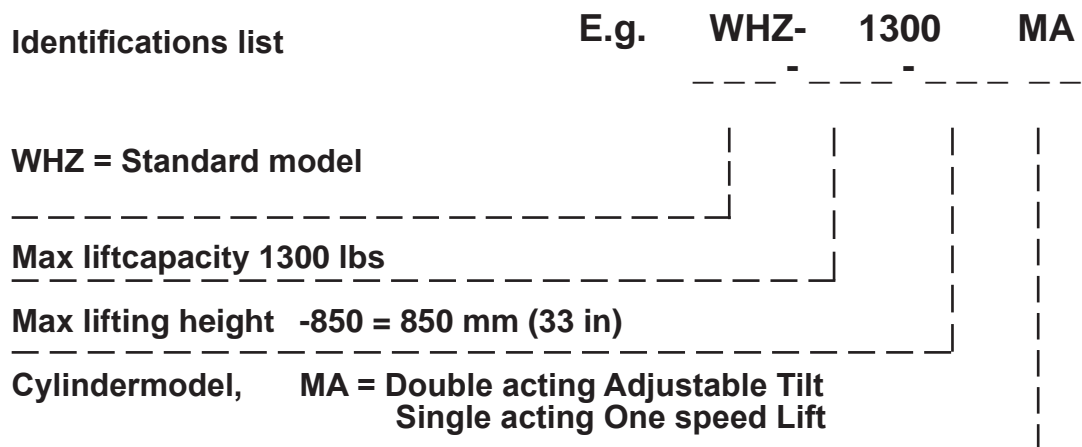

Weights

Some components of the tail lift must be manipulated by other lifting equipment during handling and therefore could represent hazards if their weights exceed the equipment's permitted load. The following are the ranges of weights for various heavy components.

Cpl. Lift chassis (without platform)

WHZ 287 lbs

Aluminiumplatforms

Alu. platform 1200x1400 mm	126 lbs
Alu. platform 1500x1400 mm	143 lbs
Alu. platform 1600x1400 mm	150 lbs

Lift components (part of cpl. lift chassis).

Support frame	45 lbs
Liftarm	49 lbs
Supporting arm	13 lbs
Connecting link	3 lbs
Liftcylinder	12 lbs/st.
Tiltcylinder	16 lbs
Hydraulic Unit	29 lbs

2. General

Center of gravity

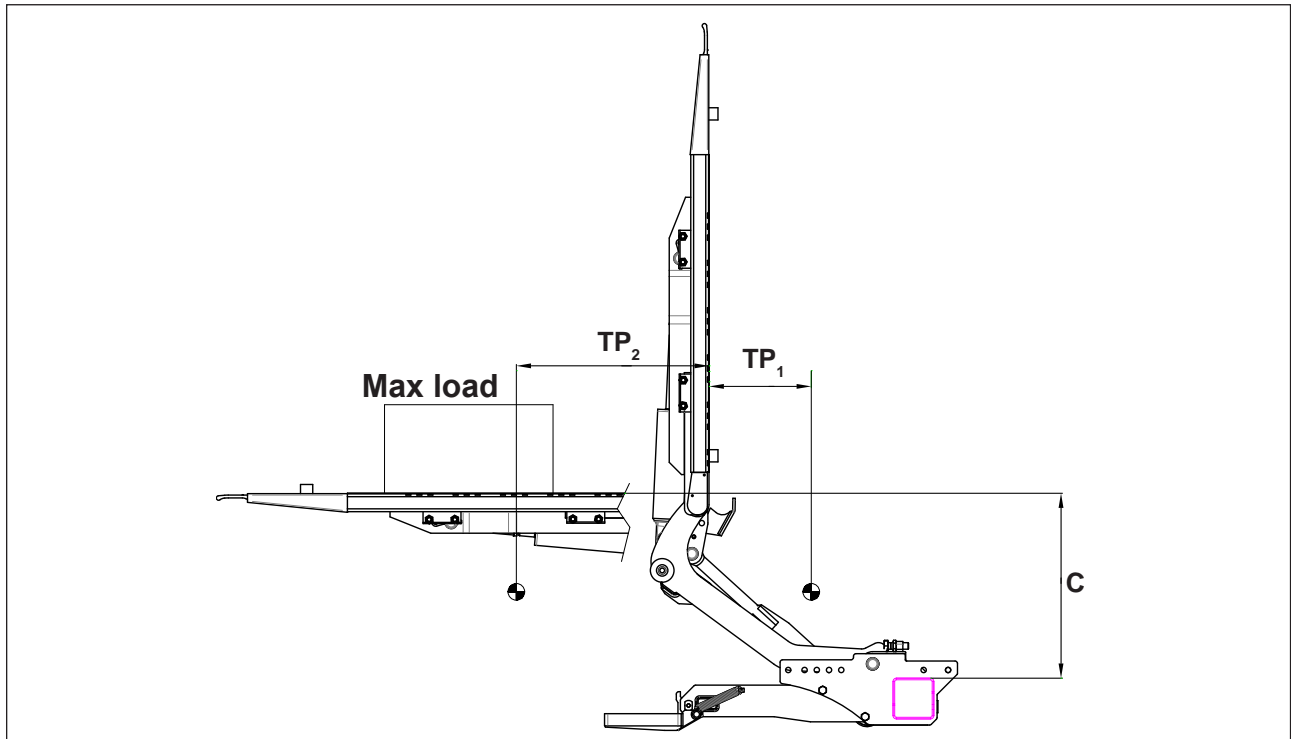

2. General

Max Power Consumption

WHZ 1300 (2,750 psi)

	12 Volt	24 Volt
Pump - Motor Unit	110 A	60 A
Magnet (hydraulic unit)	1,4 A	0,7 A
Magnet (electric safety valve)	1,5 A	0,75 A
Solenoid	1,8 A	0,9 A
Cable area:		
Control cable	1,5 mm ²	1,5 mm ²
Main cable 0-8 m	35 mm ²	35 mm ²
Main cable 8-15m	35 mm ²	35 mm ²
Main cable < 15m	-	35 mm ²
Power source:		
Min. capacity	140 Ah	110 Ah
Min. voltage	9 Volt	18 Volt

Loading Diagram

MAX 600kg

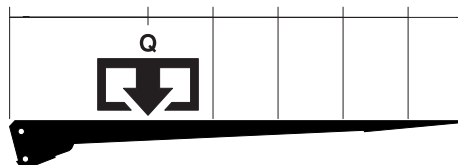
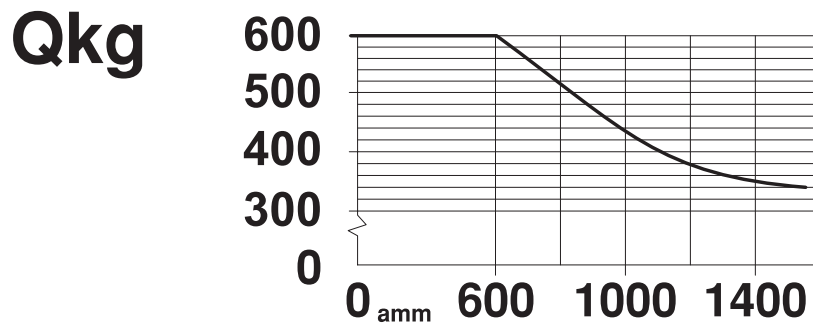

22685TL

3. Dimensions for installation

WHZ 600-850

No cuts outs from the rear frame necessary

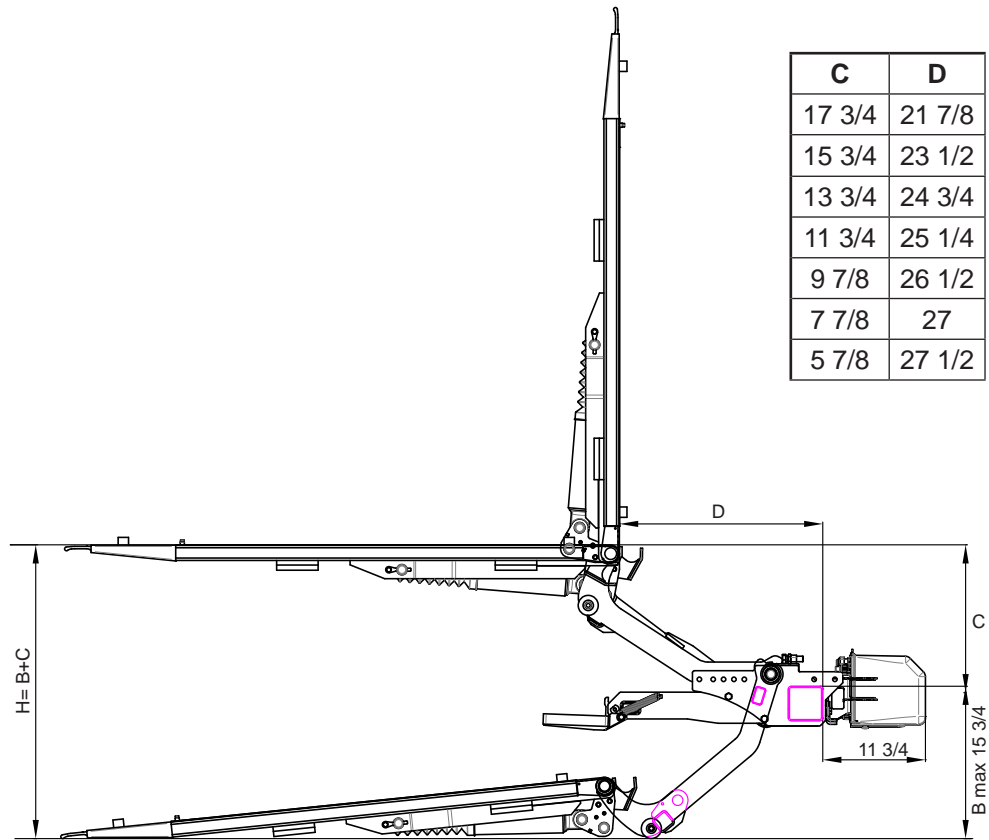

4. Introduction

WHZ 1300 is intended for installation on vans and light trucks.

WHZ 1300 assembly is based on the use of our mounting kits, the mounting kits are specially designed to specified van or light truck. Only mounting kits that are manufactured or approved by WALTCO, can be used.

Mounting kit and vehicles factory made mounting points will determine the position of the liftgate.

Note!! Tow hook device cannot be combined with liftgate installation.

Principal order of mounting operations

- Install the mounting kit
- Premounting of the lifting gear
- Mounting of the power pack
- Mounting of the hydraulic hoses
- Connecting the push button boxes
- Electrical wiring
- Mounting of platform
- Test use and checking / fixing of dimensions and movements
- Mounting of rubber seals / rubber bumpers
- Final mounting
- Adjusting the tilting cylinder
- Install over drive bridge
- Mounting of labels
- Test run and final inspection

Main dimensions are determined by the mounting kit. Note dimensions of installation in case of not using mounting kit.

The most important distance is C, distance between body floor level and the bottom of the chassis beam. When C- distance is known, D- distance may be obtained from charts. D- distance will determine space which is required for liftgate. With C- and D- distance you can check that there is enough room for liftgate.

H- distance is unloaded body height from the ground. H- distance must be less than the liftgates max lifting height, do not exceed the liftgates max lifting height. If the liftgates max lifting height is exceeded, the platform will not reach the ground level in all vehicle positions. The support surface of the platform bracket must always reach the ground, installation where the support surface is not reaching the ground is forbidden.

NOTE! Liftgate must not be mounted directly against vehicle's frame, there must be small gap between liftgates frame and vehicles frame. This gap will allow movements of vehicle's frame. Remember this when calculating C- distance.

WARNING! WHZ 1300 can only be mounted with mounting kit supplied or approved by Waltco.

WARNING! Installation where the support surface is NOT reaching the ground is forbidden.

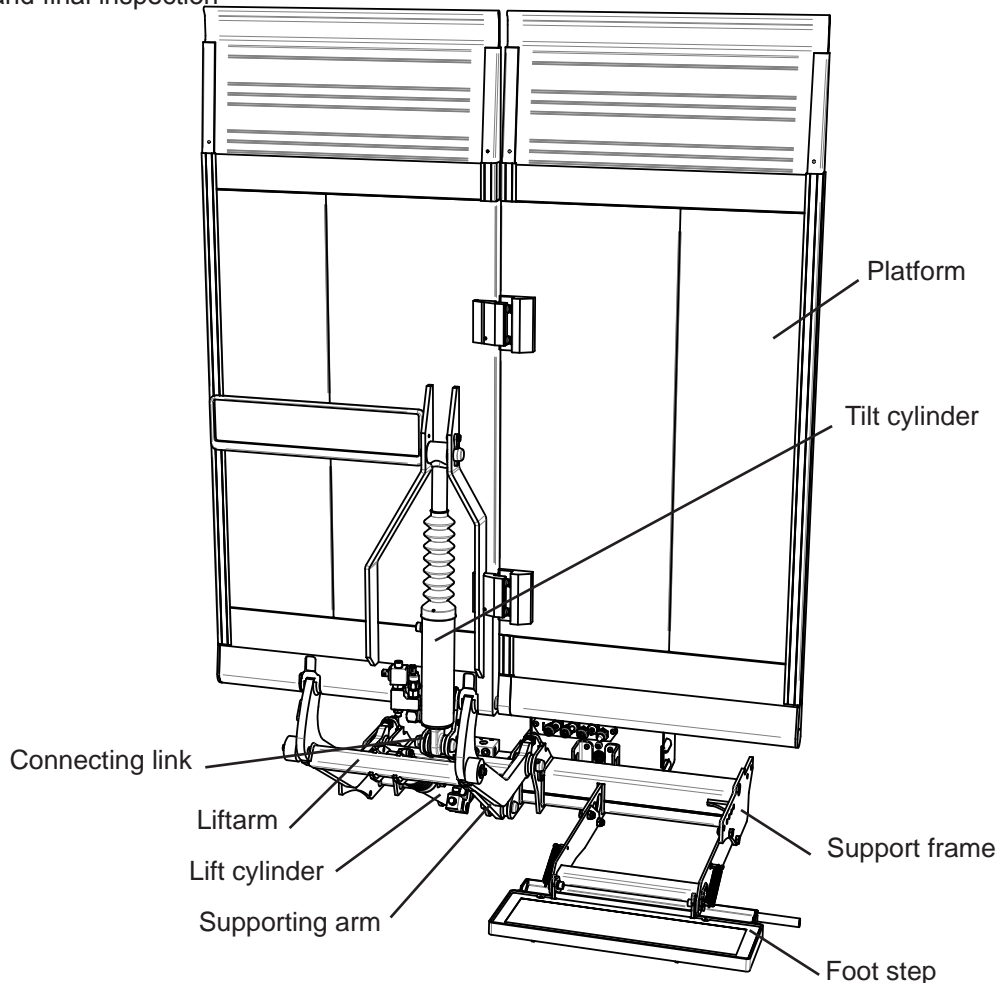

5. Mounting kits

MANUFACTURER	MODEL	VERSION	MORE	CPL. WEIGHT	ART. NO.	PAGE
Fiat Peugot Citroen	Ducato Boxer Jumper	Year from 2007	L= 118 1/8, 135 3/4, 158 7/8 X = 40	53.1 lbs	72807TL	12
VW Mercedes	Crafter Sprinter	Year from 2006	L= 170 1/4 X= 63 5/8, 79 3/8	30.9 lbs	73169TL	15
VW Mercedes	Crafter Sprinter	Year from 2006	L= 144 1/4	54.9 lbs	73167TL	19
Ford	Transit	Year from 2006	L= 130, 147 5/8 X = 39 1/4	28.0 lbs	73029TL	17

L = wheelbase (in)

X = rear overhang (in)

5. Mounting kits

Fiat Ducato, Peugeot Boxer, Citroen Jumper (art. no. 72807TL)

Year from 2007

1.) Disassemble spare wheel with its brackets and optionally stair.

Spare wheel should then be installed inside vehicle. As a suggestion on the wheelhouse. Bodybuilder arranges that.

There is no space under the vehicle for the spare wheel after installing the lift.

1.1) Grind away the welded bolt on the lower position of the bumper bar bracket., drill a hole \varnothing 11 trough vehicle's bracket for a M10 screw. Spacer 20 mm is used. Apply some rust preventives at the drilled hole.

1.2) Install frame bracket loose.

Mounting gap between frame bracket and the lifts measure (39 1/4") should not exceed 1/16".

1.3) Offset the frame bracket 3/4" sideways to the left of the vehicle's drive direction to avoid conflict with back door. (Foldable platform) If the lift is mounted symmetrically spacers 14+6 mm is not needed. (Ordinary platform)

2.) Install the lift loose so that it's adjustable in the the frame bracket. Use 3 pcs of bolted joints to the right of the cut out in the frame bracket and 2 pcs of bolted joints to the left of the cut out.

2.1) Adjust the lift arm to approx. 1" with adjusting screws.

2.2) Adjust the lift so close as possible to the backdoors of the vehicle.

2.3) Draw all joints with specified torque.

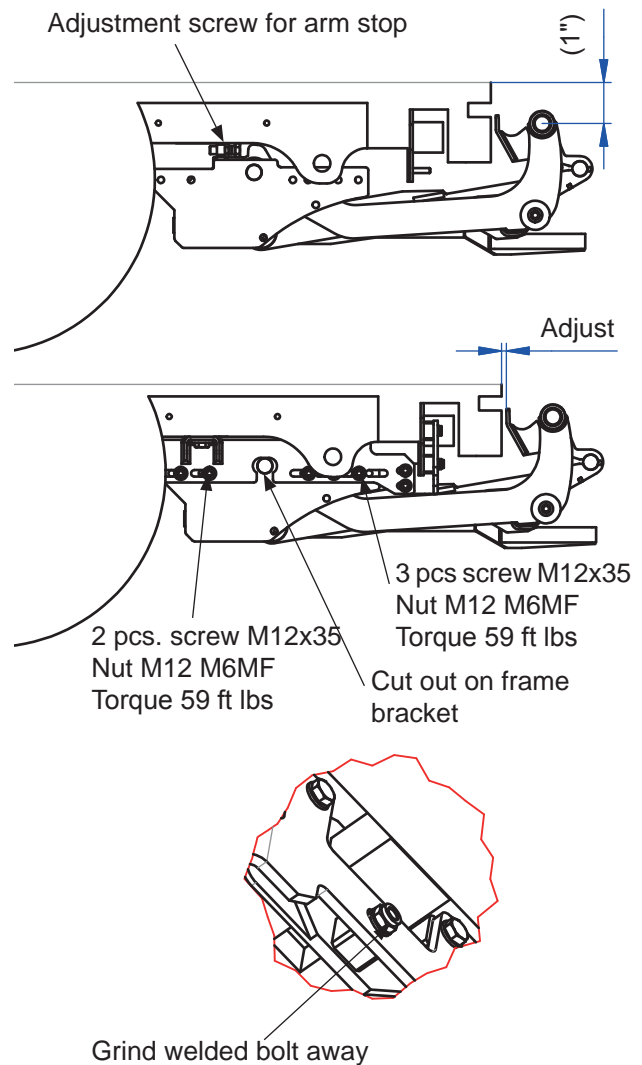

5. Mounting kits

Fiat Ducato, Peugeot Boxer, Citroen Jumper (art. no. 72807TL)
 Year from 2007

1 pce. screw M16x40
 Bracket M16
 Square washer
 Torque 89 ft lbs

2 pcs. screw M10x55
 Washer
 Nut M10 nyloc
 Spacer 20 mm
 Torque 39 ft lbs

1 pce. washer
 Nut M10 nyloc
 Space 20 mm
 Torque 39 ft lbs

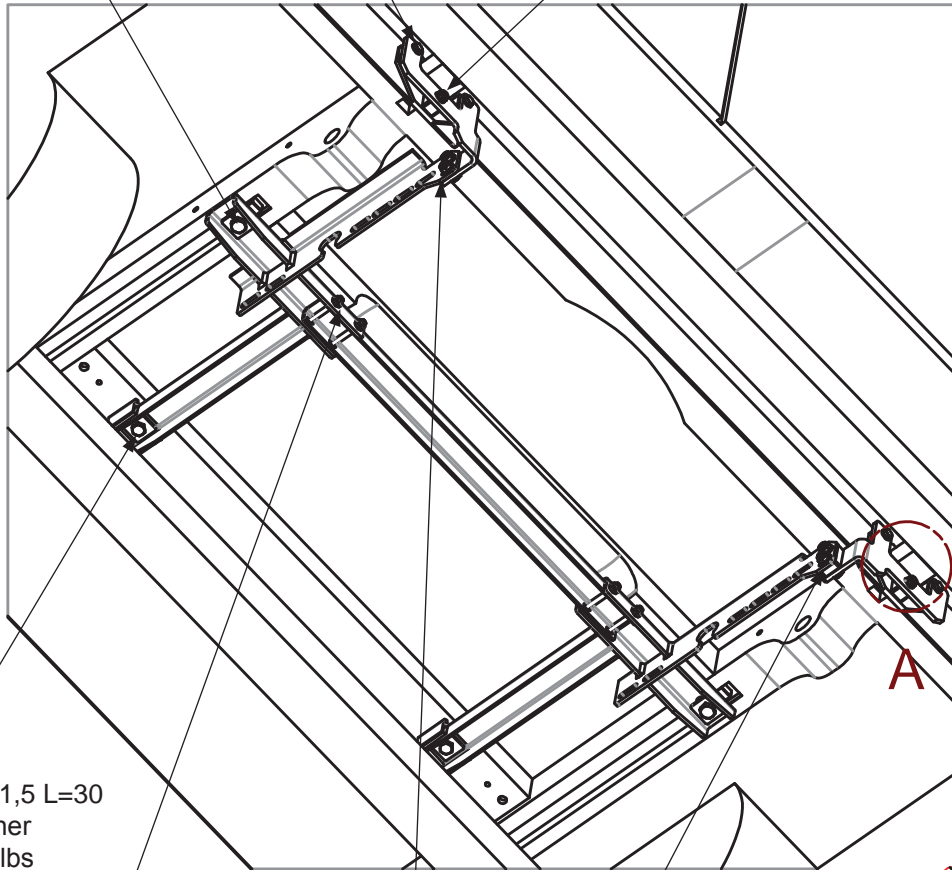

Screw M14x1,5 L=30
 Square washer
 Torque 89 ft lbs

2 pcs. screw M12x30
 Washer
 Nut M12 nyloc
 Torque 59 ft lbs

2 pcs. screw M12x35
 Washer
 Nut M12 nyloc
 Torque 59 ft lbs

2 pcs. screw M12x50
 Washer
 Nut M12 nyloc
 1 pce. spacer 14 mm
 Torque 59 ft lbs

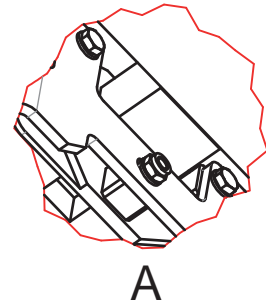

5. Mounting kits

Fiat Ducato, Peugeot Boxer, Citroen Jumper (art. no. 72807TL)

Year from 2007

3.) Install platform

3.1) Install tilt cylinder between link and platform.

3.2) Continue the installation according to standard installation instruction for the lift.

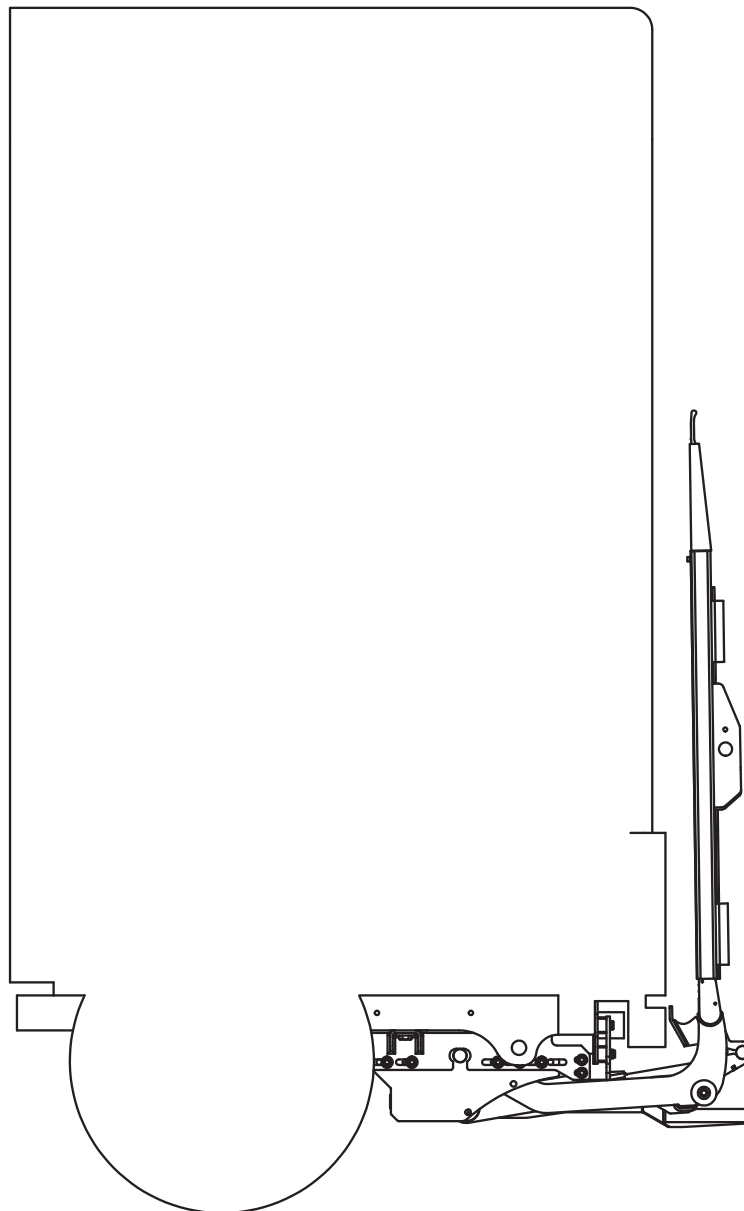

5. Mounting kits

VW Crafter, MB Sprinter 4325 (art. no. 73169TL)

Year from 2006

1.) Disassemble spare wheel with its brackets and stair. If there is a towbar it must also be removed.

1.1) Install frame bracket with two M12x100 so that it can be used as a template and mark hole 27/64" in vehicle frame.

1.2) Then remove the frame bracket.

1.3) Drill a hole 19/32" through the frame of the vehicle.

1.4) Apply some rust preventives at the drilled hole.

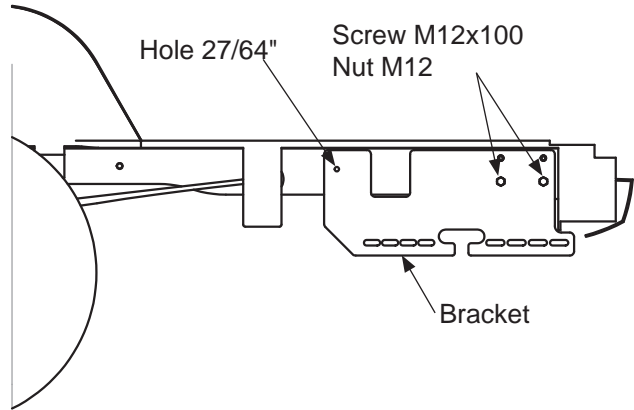

2.) Install frame bracket on the outside of vehicles frame and reinforcement plate on the inside.

2.1) Install spacer in the drilled hole.

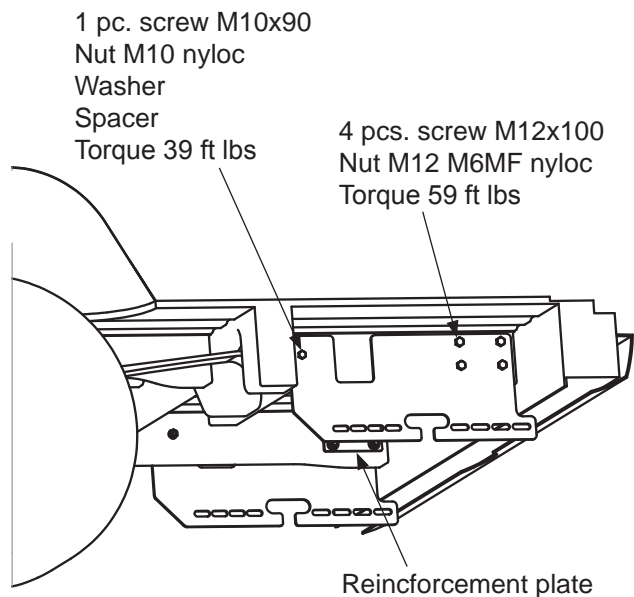

3) Install the lift loose so that it's adjustable in the frame bracket. Use 3 pcs. of bolted joints to the right of the cut out in the frame bracket and 2 pcs. of bolted joints to the left of the cut out.

3.1) Adjust the liftarm to approx. 1" with adjusting screws.

3.2) Continue the installation according to standard installation instructions for the lift.

3.3) Adjust the lift so close as possible to the backdoors of the vehicle.

3.4) If necessary make cut out's on the bumper bar.

3.5) Draw all joints with specified torque.

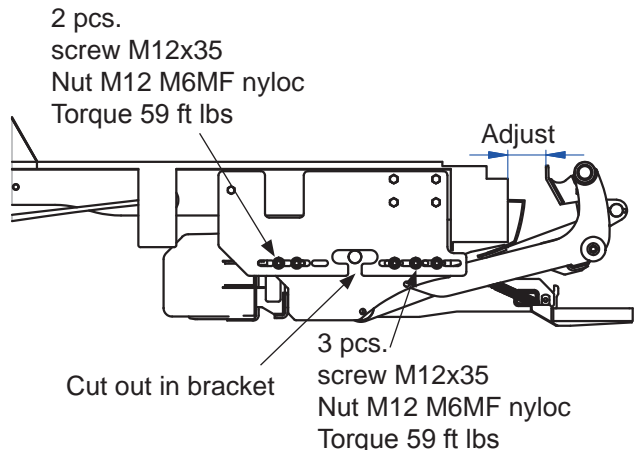
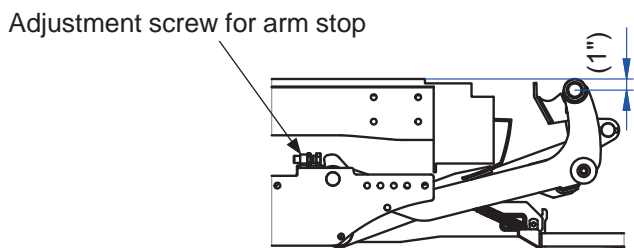

5. Mounting kits

VW Crafter, MB Sprinter 4325 (art. no. 73169TL)

Year from 2006

4.) Install platform.

4.1) Install tilt cylinder between link and platform.

4.2) Continue the installation according to standard installation for the lift.

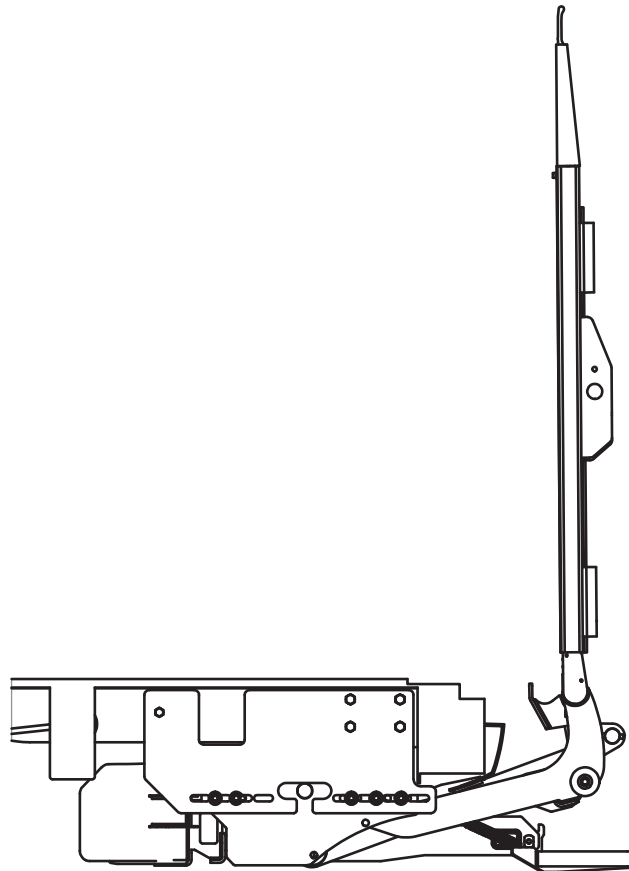

5. Mounting kits

Ford Transit (art. no. 73029TL)

Year from 2006

1.) Disassemble spare wheel with its brackets and optionally stair.

Spare wheel should then be installed inside vehicle. As a suggestion on the wheelhouse. Bodybuilder arranges that.

There is no space under the vehicle for the spare wheel after installaing the lift.

1.1) Disassemble bumper bar brackets. Remove towing eye and nuts. Apply some rust preventives afterwards on brackets.

1.2) Check holes in frame so that distance tube fits. If necessary drill 13/16" so that they can be installed. Apply some rust preventives at the drilled hole.

1.3) 4 pcs. screws which holds the bumper bar brackets must be replaced with supplied screws M12x110.

1.4) Install the frame and bumper bar brackets. Draw all joints with specified torque.

2.) Install the lift loose so that it's adjustable in the frame bracket. Use 3 pcs. of bolted joints to the right of the cut out in the frame bracket and 2 pcs. of bolted joints to the left of the cut out.

2.1) Adjust the lift arm to approx. 1" with the adjusting screws.

2.2) Adjust the lift so close as possible to the backdoors of the vehicle.

2.3) Draw all joints with specified torque.

2.4) Continue the installation according to standard installation instructions for the lift.

5 pcs. screw M12x110
Nut M12 nyloc
10 st. washer
Torque 59 ft lbs

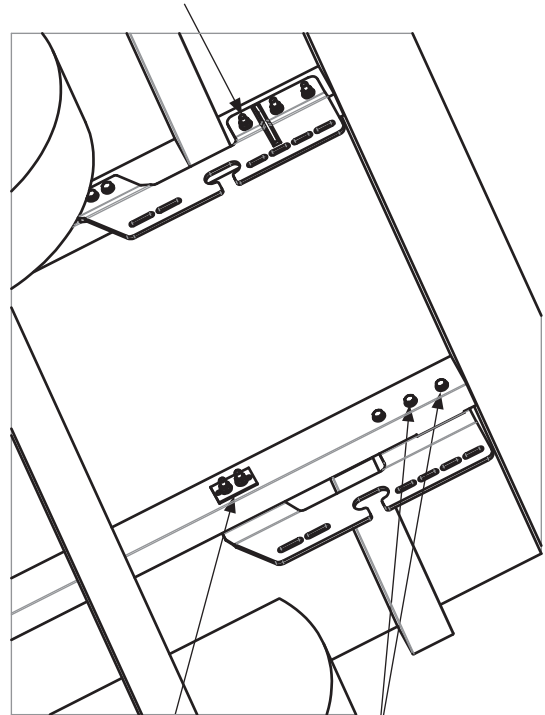

1 pce. Washer plate
2 pcs. Spacer tube

Replacing screws

Adjustment screws for arm stop

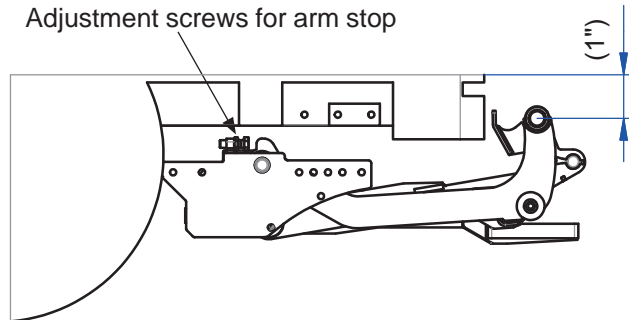

2 pce.
Screw M12x35
Nut M12 M6MF nyloc
Torque 59 ft lbs

Adjust

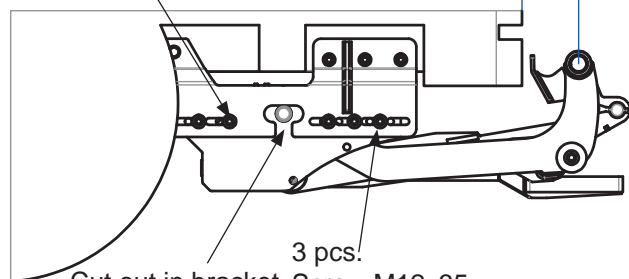

3 pcs.
Screw M12x35
Nut M12 M6MF nyloc
Torque 59 ft lbs

5. Mounting kits

Ford Transit (art. no. 73029TL)

Year from 2006

3.) Install platform.

3.1) Install tilt cylinder between link and platform.

3.2) Continue the installation according to standard installation instruction for the lift.

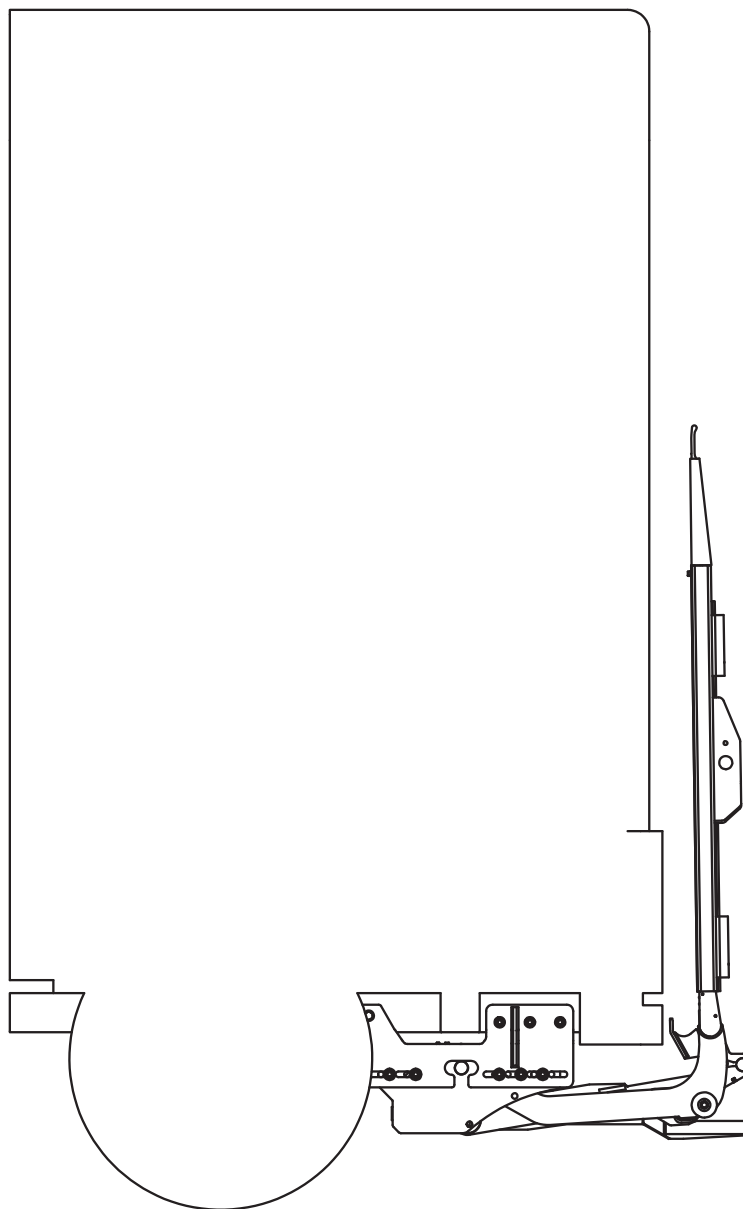

5. Mounting kits

VW Crafter, MB Sprinter 3665 (art. no 73167TL)

Year from 2006

1.) Disassemble spare wheel with its brackets and stair. If there is a towbar it must also be removed.

1.1) Install outer and inner frame bracket with 4 M12x100.

1.2) Install space tubes.

1.3) Drill a hole \varnothing 1/2" in the frame from both sides with help of outer and inner frame bracket.

1.4) Apply some rust preventies at the drilled hole.

1.5) Install screw M12x100 trough the frame.

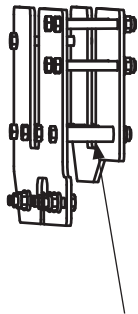

4 pcs. space tubes is installed below frame.

2) Install the lift loose so that it's adjustable in the frame bracket. Use 3 pcs. of bolted joints to the right of the cut out in the frame bracket and 2 pcs. of bolted joints to the left of the cut out.

2.1) Adjust the liftarm to approx. 1" with adjusting screws.

2.2) Continue the installation according to standard installation instructions for the lift.

2.3) Adjust the lift so close as possible to the backdoors of the vehicle.

2.4) If necessary make cut out's on the bumper bar.

2.5) Draw all joints with specified torque.

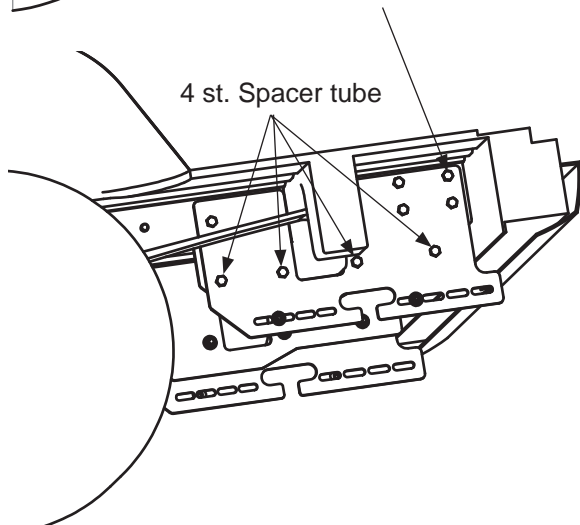
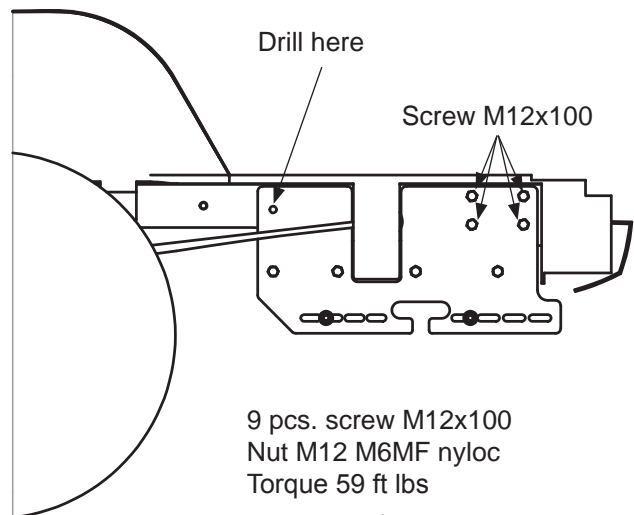

Adjustment screw for arm stop

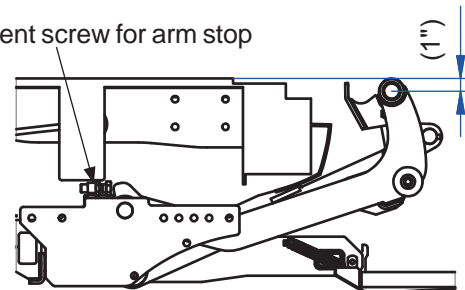

2 pcs.
Screw M12x35
Nut M12 M6MF nyloc
Torque 59 ft lbs

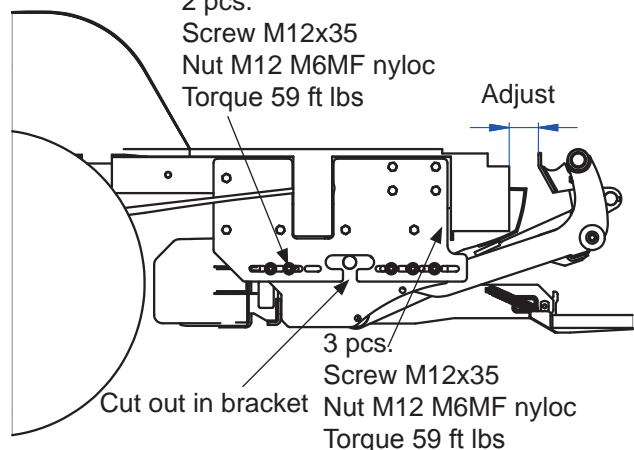

5. Mounting kits

VW Crafter, MB Sprinter 3665 (art. no. 73167TL)

Year from 2006

3.) Install platform.

3.1) Install tilt cylinder between link and platform.

3.2) Continue the installation according to standard installation for the lift.

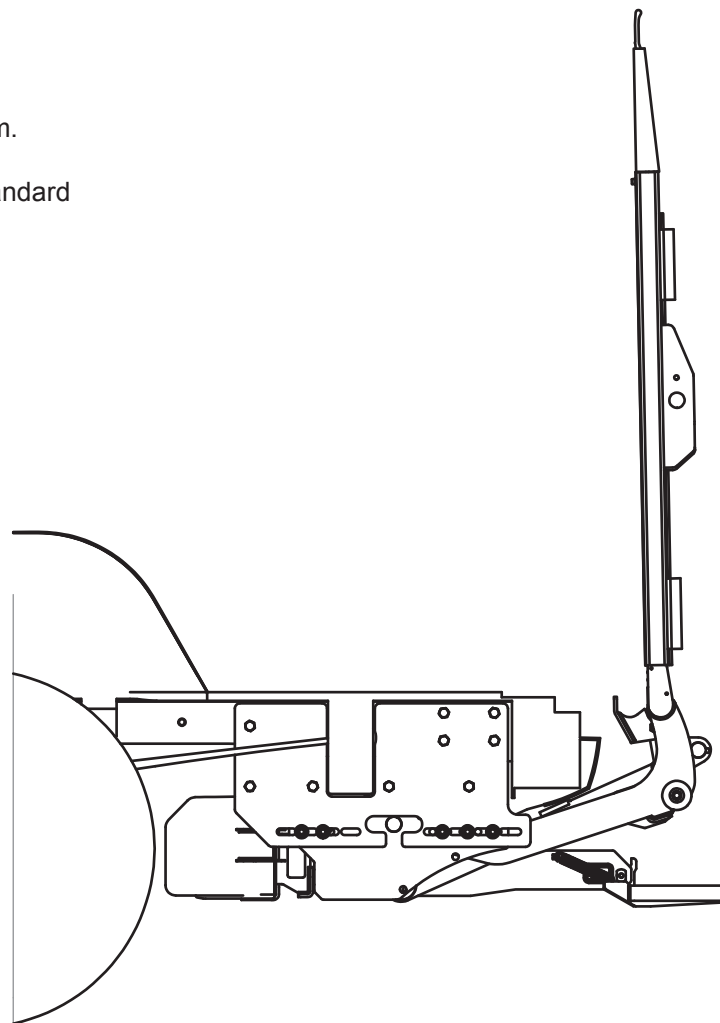

5. Mounting kits

Power pack installation

Note! Replace the transport plug with regular filler cap before the plugs on port A and B are removed.
We recommended that power pack will be installed inside cargo area, above the inner wing, using included mounting bracket.

Connect hydraulic hoses to hydraulic unit as following:

The power pack can be mounted horizontal or vertical.

Return side tilt cylinder (A), Pressure side lift/tilt cylinder (B).

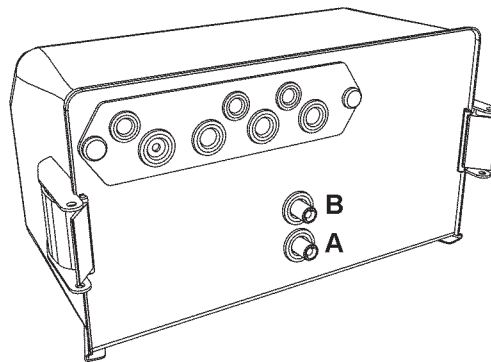

6. Electrical installation

Install control units at suitable places, but the position of the control unit should ensure that the operator has a good view of the load, the working area and the loading area, whilst maintaining a safe distance from the risk zone between the platform and the body. Note that all cables must be connected from below so that water can't get into the units but condensation can drain out.

The control cable is connected to the circuit card in the connection unit (see electric schematic). Install the control current cable from the dashboard of the truck according to the customers requirements. The control current switch should be located so it is possible to be reached from the ground 10 A (24 V), 15 A (12 V) fuse between the current source and the switch. The control current cable is connected to a fixed control unit. You can fasten the cable together with the main cable to the hydraulic unit.

Connect the main power cable to the + pole of the battery. The cable should be protected with a plastic sheath. It must not be fastened together with brake pipes or other electric cables of the truck. When passing through holes the cables must be protected with rubber bushings.

A 150 A (24 V) or 250 A (12 V) fuse is to be installed on the main power cable running from the battery compartment**. This acts to protect the electrical systems from overloading and the risk of fire. The picture below shows proper connection.

If you want an electrically heated spiral cable unit you can order a 5-part cable (spare-part no 21303). Note that the spiral cable unit must have its fastening plate for the wall (spare-part no 20302).

Check that the hydraulic unit is well earthed according to truck manufacturer's instructions (earthing is made through leading in plate, see picture).

If you must lead a spiral cable up through the floor you must protect it with a sheath up from the floor. If you need to use power from the circuit card +ve connection point a fuse must be installed, eg. overload alarm 7.5 Ampere.

Test run all functions from all control units.

**Note! The fuse should be placed on a well protected place and as near as possible to the battery.

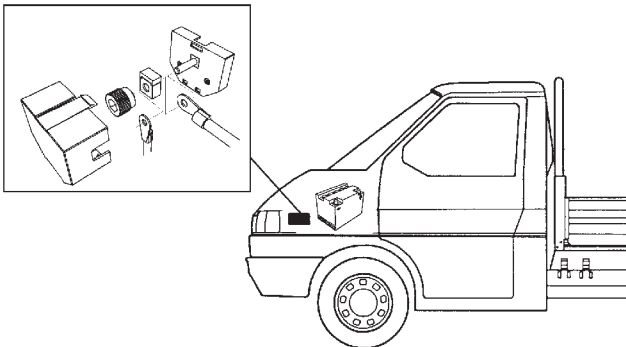

7. Electric and hydraulic diagram

WHZ 1300

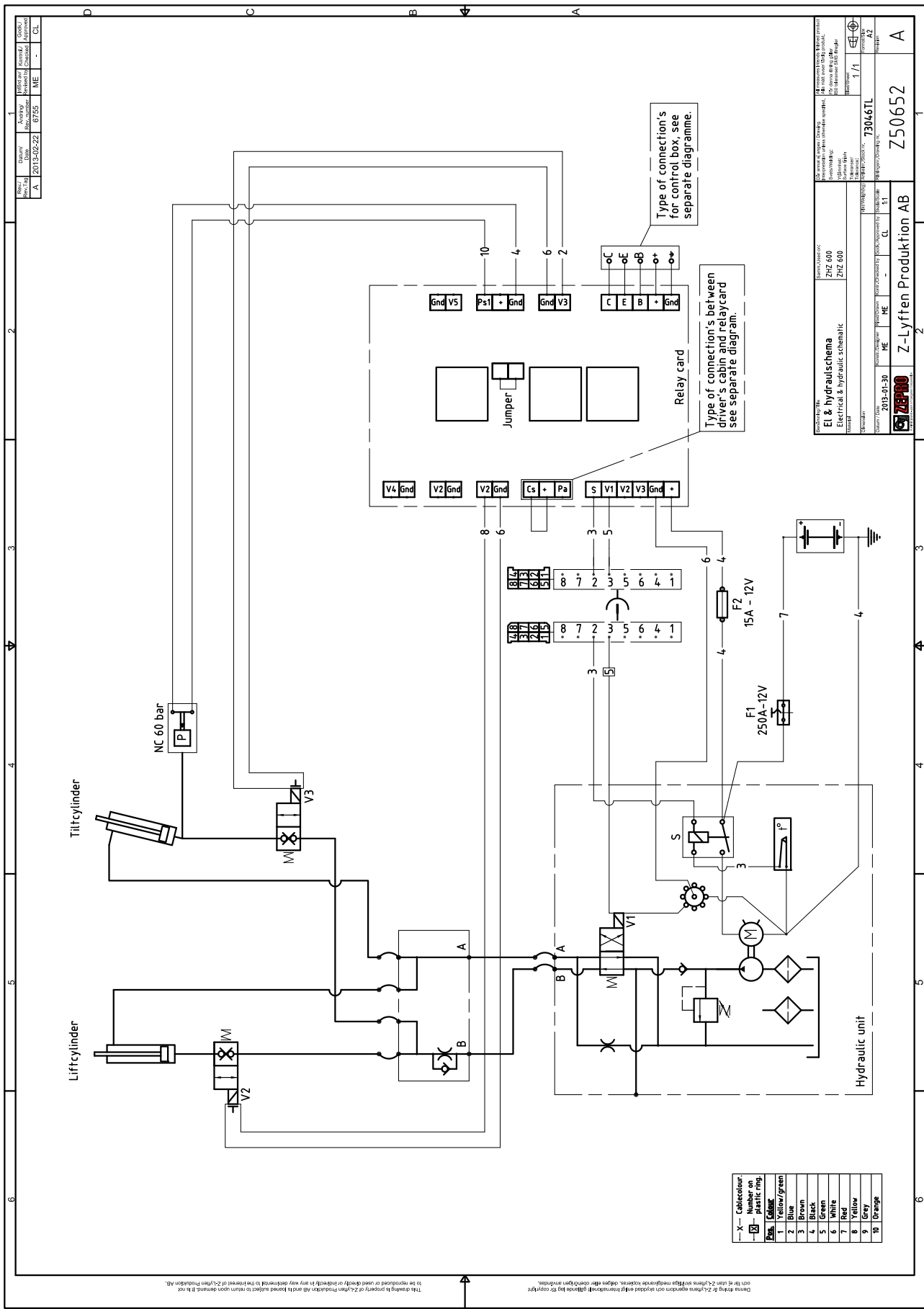

7. Electric and hydraulic diagram

Control unit / control unit with spiral cable

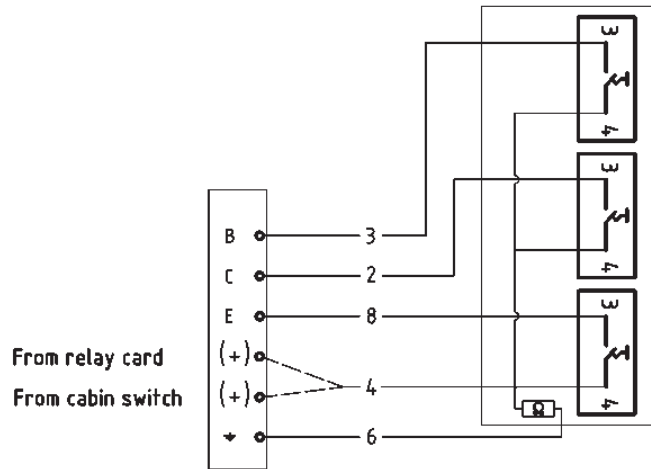

Nr. /No.	Färg / Color/Farbe
1.	Gul / Grön, Yellow / Green, Gelb / Grün
2.	Blå / Blue / Blau
3.	Brun / Brown / Braun
4.	Svart / Black / Schwarz
5.	Grön / Green / Grün
6.	Vit / White / Weiß
7.	Röd / Red / Rot
8.	Gul / Yellow / Gelb
9.	Grå / Grey / Grau
10.	Orange / Orange / Orange

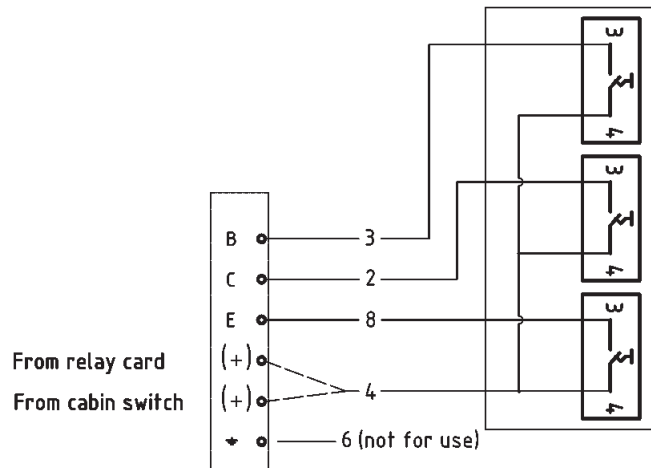

7. Electric and hydraulic diagram

Cabin switch, Alarm for open platform

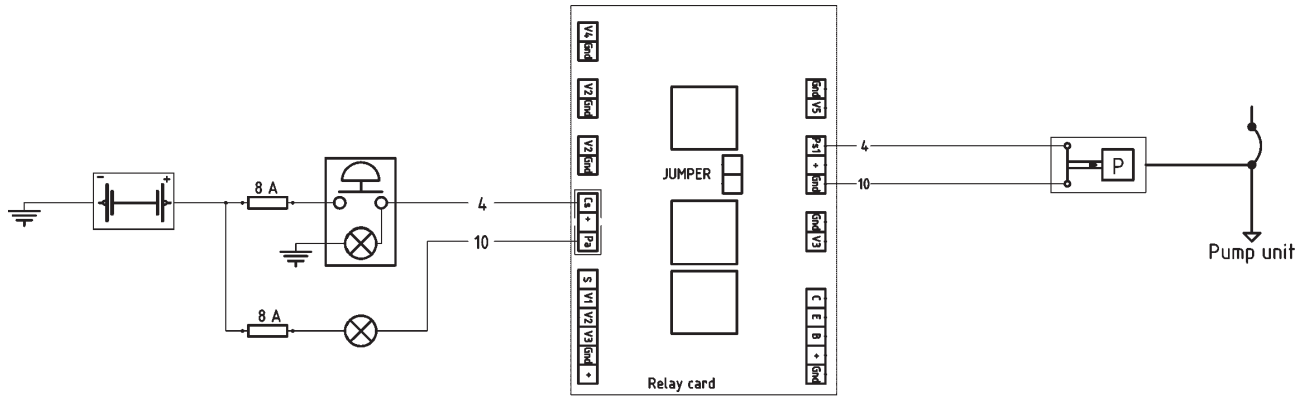

8. Installation, continued

Over drive bridge

Install over drive bridge to the vehicle in such a way that the tip of over drive bridge overlaps the platform at least 1 1/2 - 2 3/8 in.

For safety reasons the clearance between the platform and the rear beam should be at least 3" when the platform surface and the bottom of the edge of the rear beam are at the same height. If distance is less than 3" the vehicles frame must be modified.

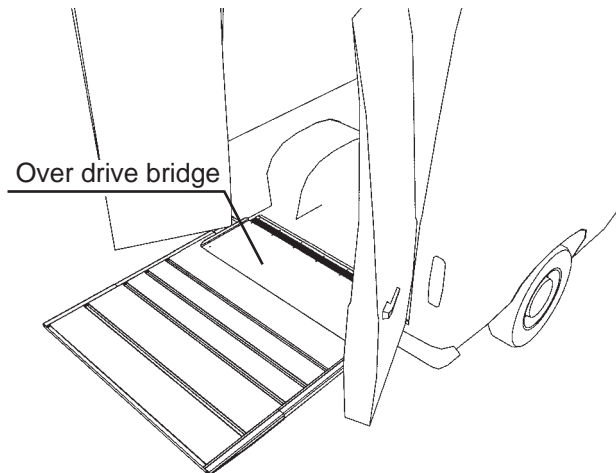

Armstops

The armstops must be adjusted after the installations of mounting kit and tail-lift.

Adjust the two screws so both of the armstops meet the liftarms at the same time.

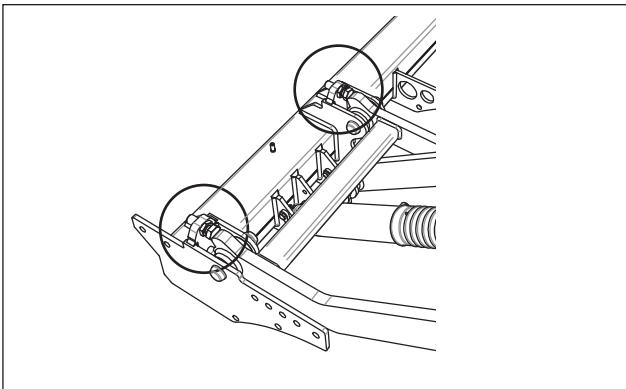

Bleeding the cylinders

For all lift cylinder models.

Fully lower the platform a few times. You may have to lift the truck to fully lower the platform.

Concerning tiltcylinder models

Tilt cylinder can be purged of air by closing the platform up against the vehicle body and then opening and tilting all the way down.

Platform stop

When the platform is folded together and closed to the rear of the body. A platform stop will automatically lock the 2 platform parts against each other.

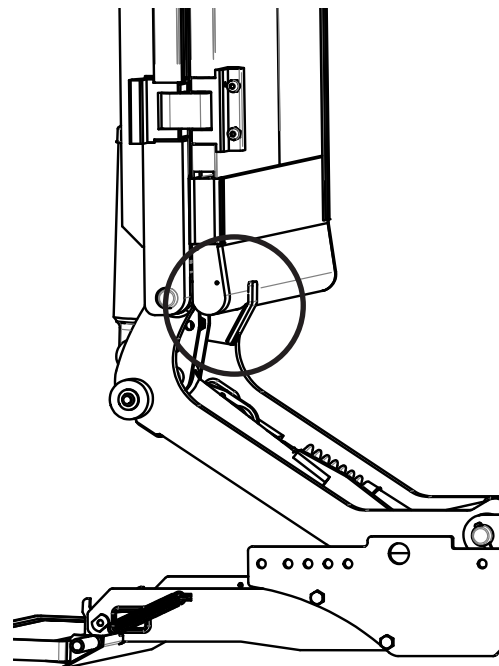

8. Installation, continued

Adjusting the tiltcylinder

The tilt cylinder can be adjusted in order that the platform is positioned vertically behind the rear of the body.

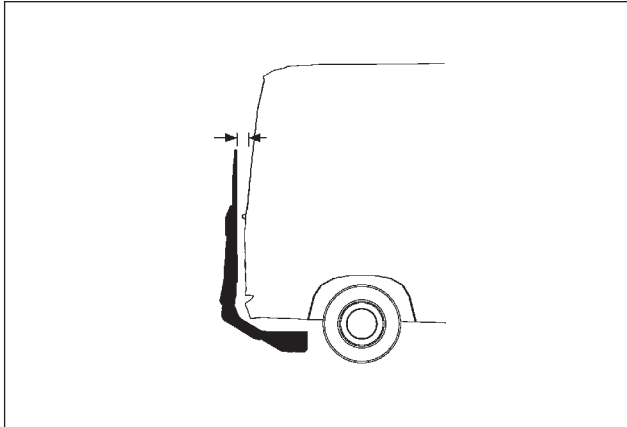

In order to adjust the tilt cylinder

Loosen the locking nuts
Grip the collar with a tool
Twist the piston rod clockwise or anti-clockwise depending on the required direction of adjustment. See diagram

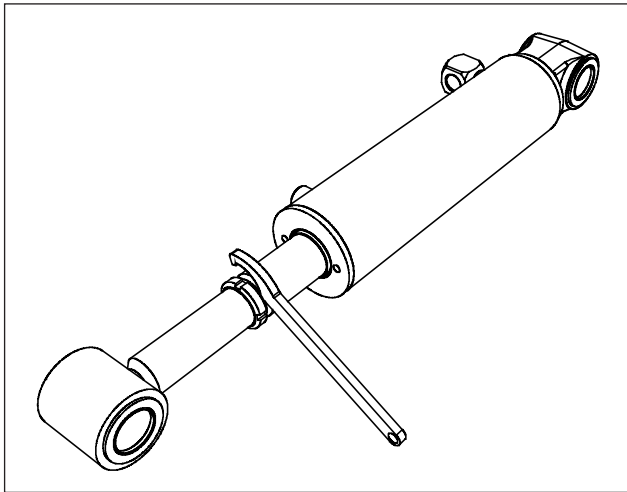

Adjust the tilt cylinder when horizontal.
Clockwise adjustment results in the platform being lowered. Anti-clockwise adjustment results in the platform being raised

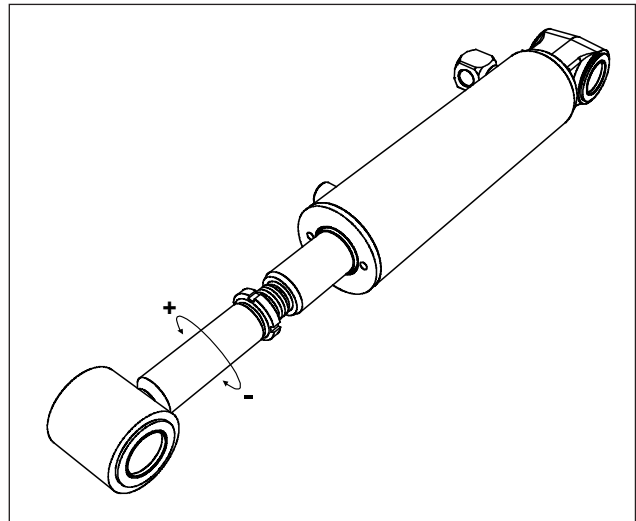

NB! DO NOT EXCEED the max. adjustment is 1 3/16".

After adjustment, tighten the lock nuts. 59 ft lbs.

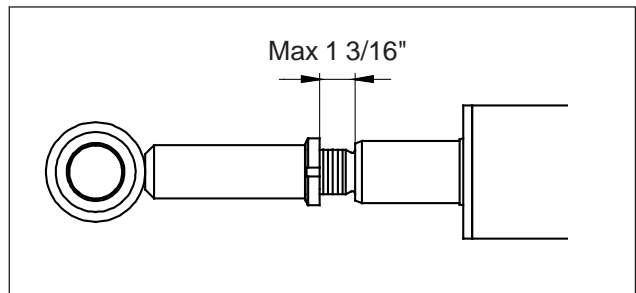

9. Important information

Repainting

NB. If the cylinders are to be repainted, ensure that the cylinder push rod and cover are not painted (this can damage the seals/gaskets). This also applies to rubber bellows if they exist!

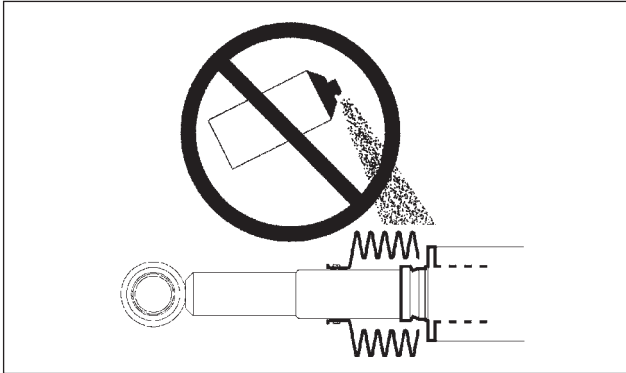

Hydraulic hoses or cables must not be painted, the paint's solvent can damage the hose's/cables rubber compound and can adversely affect durability.

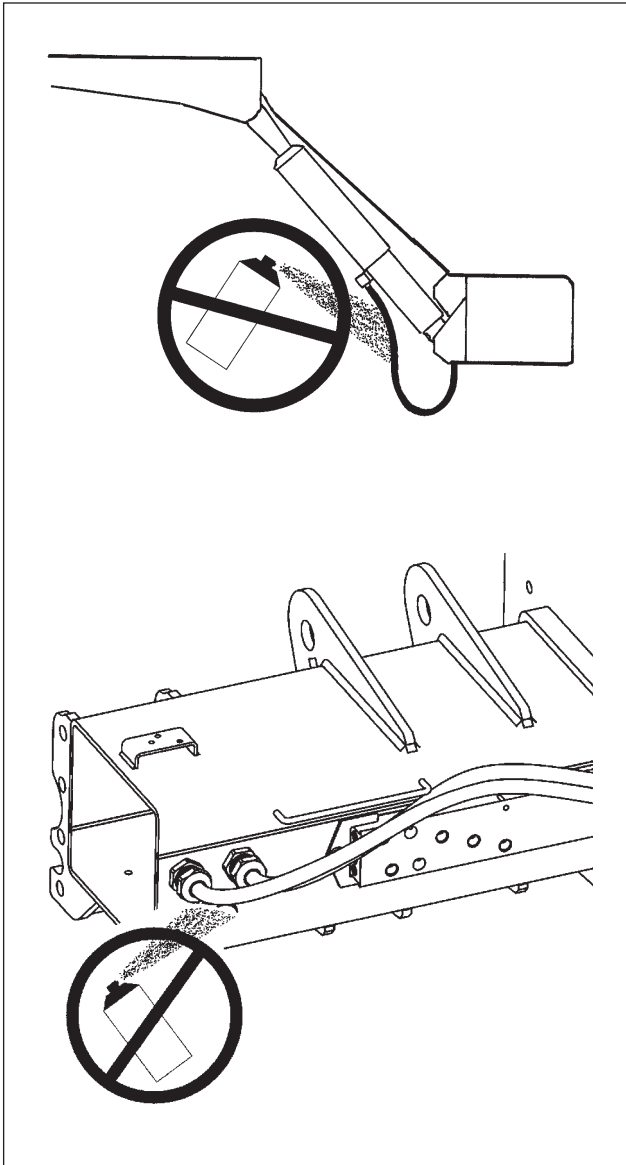

Replace the transport plug

During installation the oil tank transport plug should be removed and replaced.

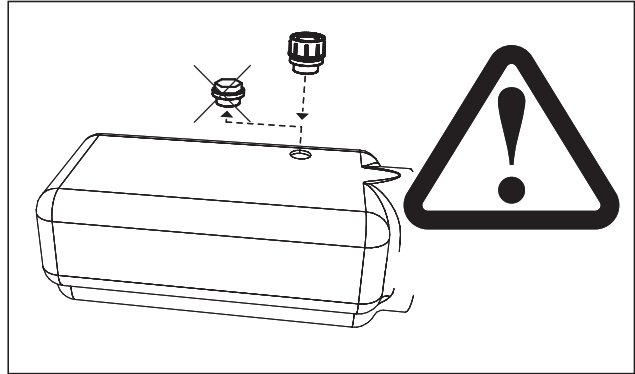

Moveable parts - free movement

When the final post-installation testing is carried out, it is important that there is sufficient clearance between the cylinders working envelopes and all fixed points. During lift operation and cylinder movement there is a risk for conflict with the subframe, truck frame, number plate, lamp holders and even the mounting brackets when the overhang is very limited (due to lift arm angle). Hence it is important to thoroughly check all of these points on both sides.

The final test is performed with the platform at floor height tilted down 10° from the horizontal. The cylinders must have a minimum clearance of 1 5/8" to all fixed points from this position.

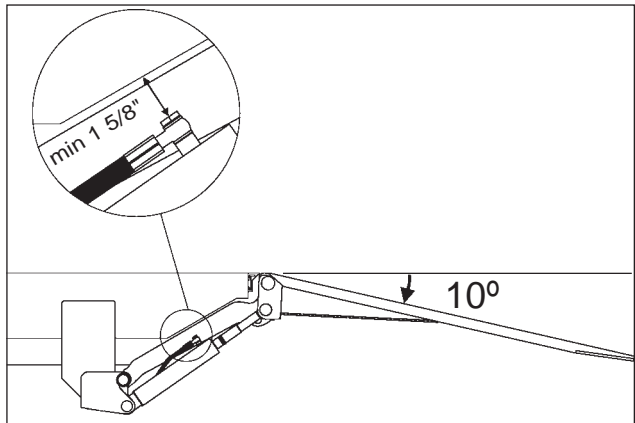

10. Markings, decals

(see pictures on next page)

The loading diagram plates should be placed near the control unit and in a clearly visible position on the platform. The plate clearly indicates the nominal loading and the diagram shows the maximum permitted loading at different positions on the platform.

The name plate is installed on the support frame of the tail lift and contains the following information:

- Lift type
- Maximum permitted load in kg
- Serial number
- Year of manufacture
- Address and tel. no. of the manufacturer
- Country of manufacture
- Type no. for bumper bar certificate (RUPD)
- Type no. for electromagnetic compatibility (EMC)

There is also a similar name plate in the form of a decal which is to be affixed to the cabin's door frame to ensure correct product identification.



The mark below represents the manufacturer's guarantee that the tail lift is designed and was supplied according to the requirements laid down in the European Machinery Directive. It is a customer's guarantee of high quality and safety.



A "danger area" decal is also to be placed on the platform warning drivers who are parking cars behind the vehicle that 5 m are necessary to allow for platform opening and sufficient maneuvering space for loading and unloading goods.

An operating instructions decal should be placed next to the main control unit.

A danger zone decal, warning of the danger area between the platform and the vehicle bed is to be affixed on the inside of the vehicle body near to the spiral cable control, if installed.

We suggest that you stick the warning tape along the side edge of the platform to make it more clearly visible when in the horizontal position.

Install the warning flags with reflection strips, as close to the top and to the side of the platform as possible, however, ensure that the flags will not detach when the platform reaches the ground. Crimp the ends of the flag profiles so that the flags stay in position.

10. Markings, decals

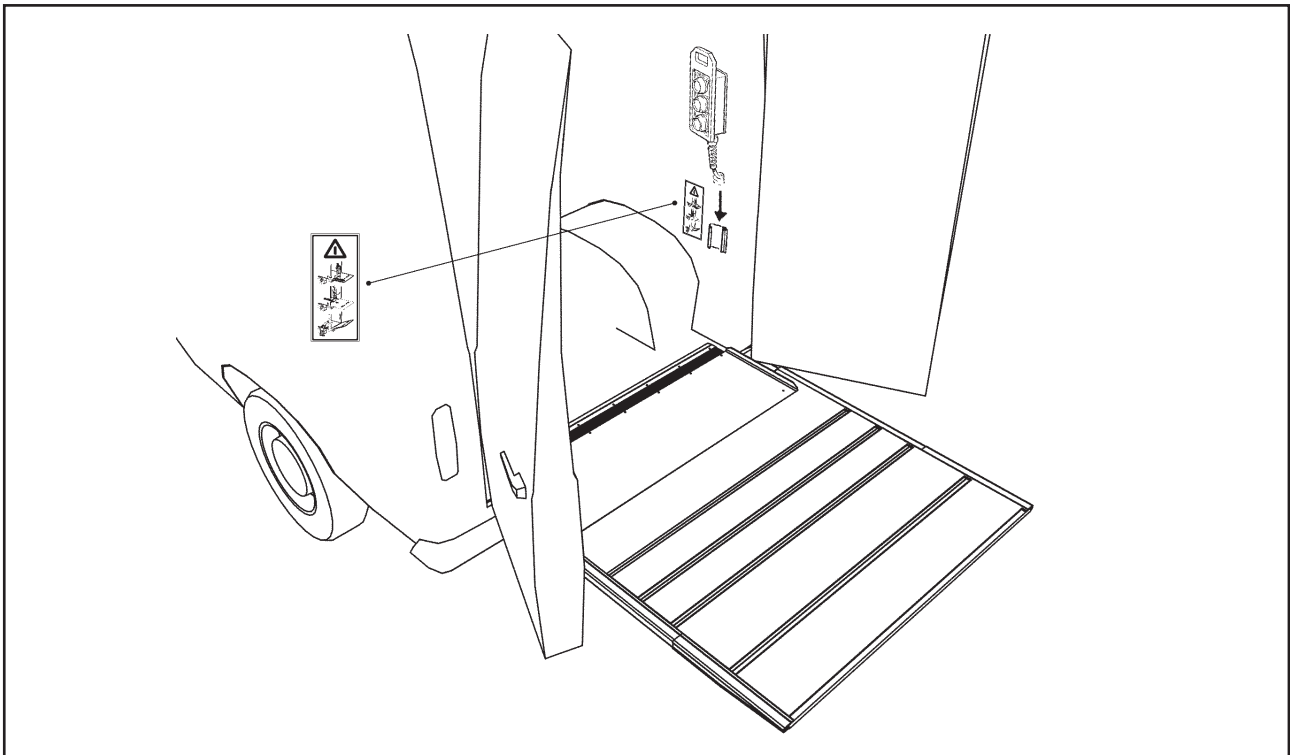
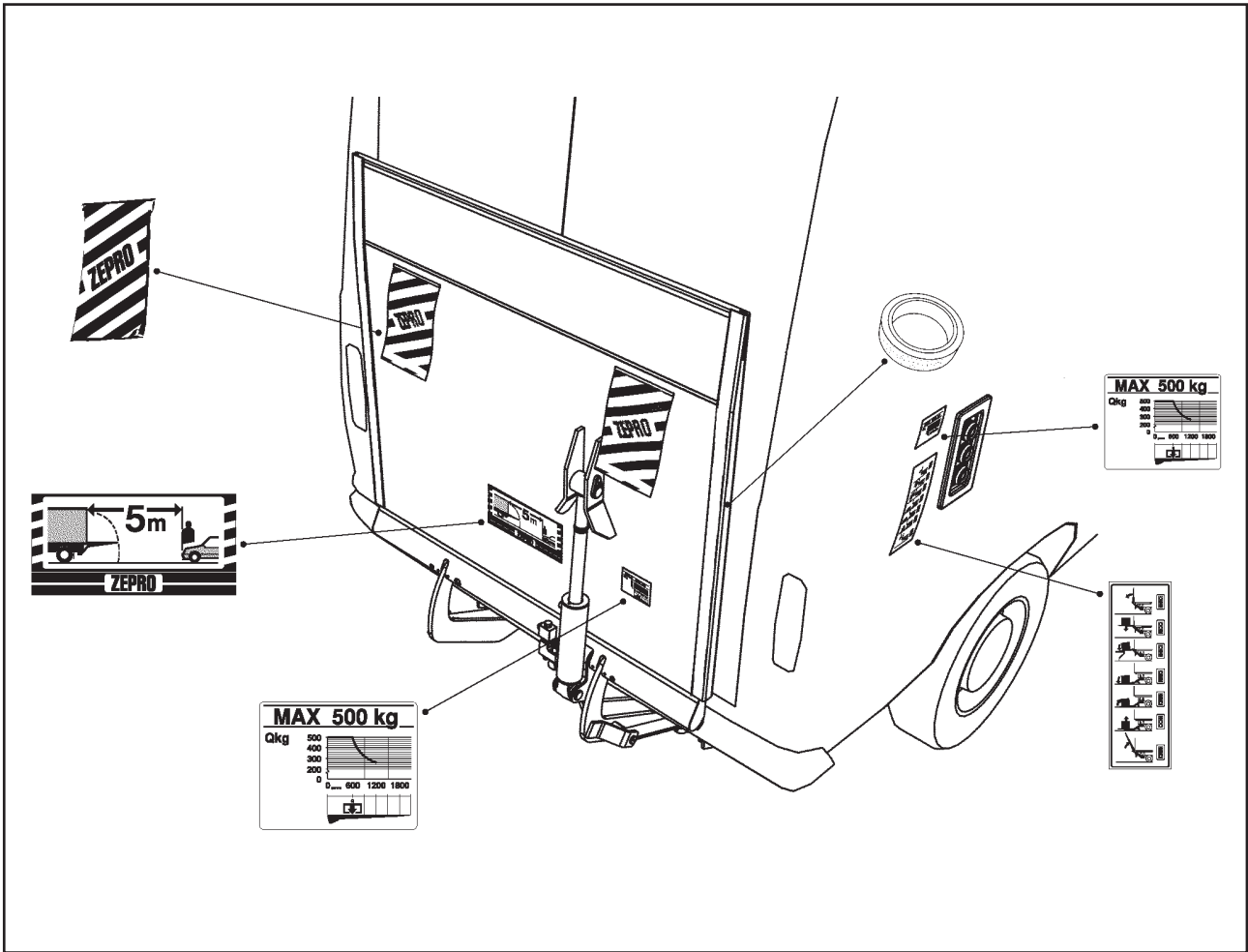

11. Load testing the tail lift

Testing and verification of the tail lift.
Carried out in accordance with the installation instruction and delivery check list.

Check that the tail lift chosen corresponds to the vehicle and to its foreseen use.

Static loading test

To be carried out when installation is complete.

Deformation

Position the tail lift with the platform horizontal about half way between the ground and the vehicle floor. Measure the distances A,B,C,D as shown in the diagram. Place a test load on the platform according to the table (for the corresponding tail lift model and loading capacity). Remove the load from the platform. Repeat the measurements of A,B,C,D and check that there is no permanent deformation to the tail lift or its brackets.

Deflection

Place a test load on the platform according to the table (for the corresponding tail lift model and loading capacity). The tail lift should be in the same level and angle as floor. Leave the test load on the platform for 15 minutes. Check that the platform's deflection is not more than 15mm vertically (point A and D) and that it is not more than 2° in angular deflection (point b and C), in relation to floor level.

Static loading (Test load 1,25 x tail lift loading capacity). For tail lifts with load centre of 600 mm

Capacity	Load 500 kg	Load 1000 kg
	Distance out in platform (L)	
450 kg	(450 kg) 675 mm	-
500 kg	750 mm	-
700 kg	1050 mm	-
750 kg	1125 mm	-
1000 kg	1450 mm	750 mm
1500 kg	2250 mm	1125 mm
2000 kg	-	1550 mm
2500 kg	-	1875 mm

Static loading (Test load 1,25 x tail lift loading capacity). For tail lifts with load centre of 750 mm

Capacity	Load 1000 kg	Load 1500 kg
	Distance out in platform (L)	
1000 kg	940 mm	-
1500 kg	1410 mm	940 mm
2000 kg	1875 mm	1250 mm
2500 kg	2340 mm	1560 mm

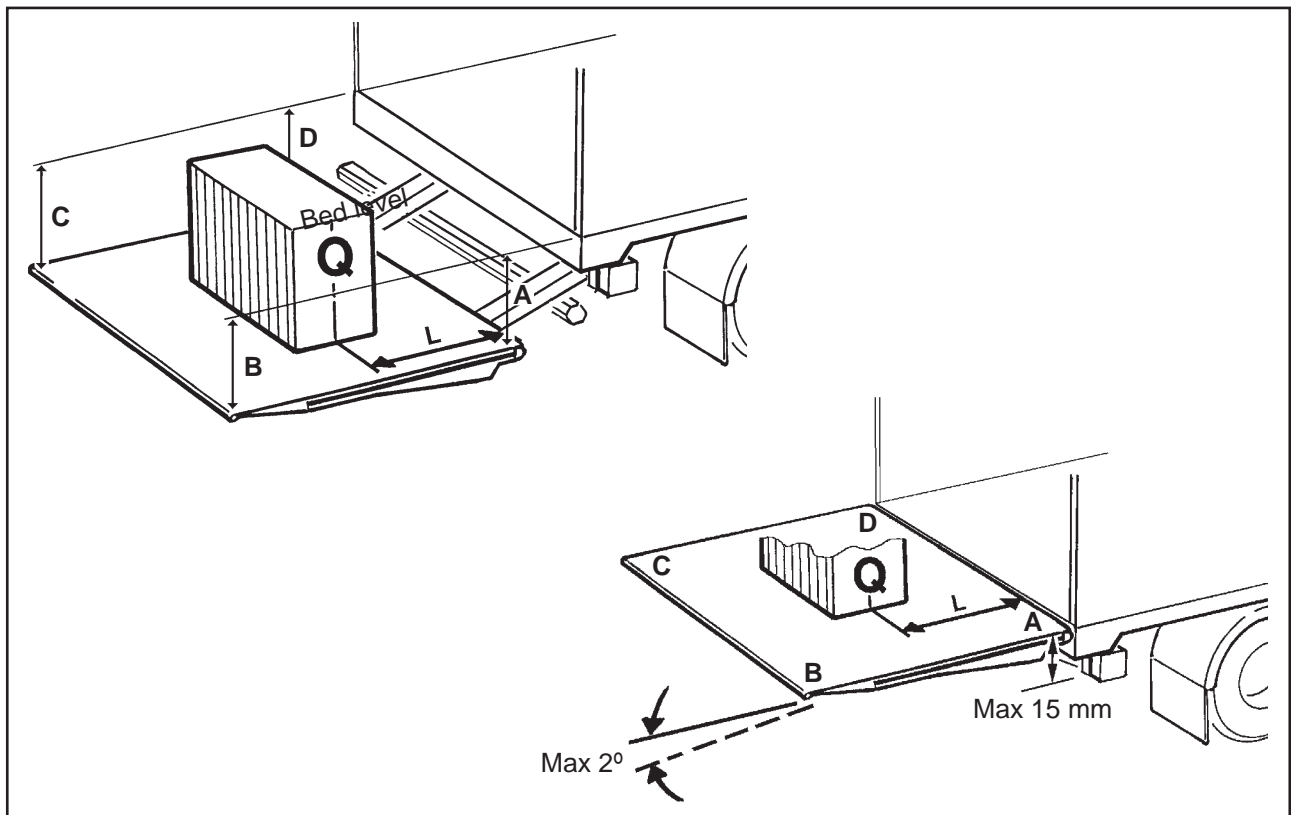

11. Load testing the tail lift

Dynamic load testing

Test with nominal load

Place a test load on the platform according to the table for the respective tail lift model and lifting capacity. Check that the tail lift operates correct in the normal range of movement allowed ie. up, down, tilting at the ground level and tilting at the vehicle floor level.

Test with over load.

Place a test load on the platform according to the table for the respective tail lift model and lifting capacity. The test load should be 1,25 x the lift models max load. Check that the tail lift cannot lift this load (it may, however, be possible to operate the tilting movement). Remove the test load from the platform.

Dynamic load (Test load 1,0 x tail lift loading capacity). For tail lifts with load centre of 600 mm

Capacity	Load 500 kg	Load 1000 kg
	Distance out in platform (L)	
450 kg	600 mm	-
500 kg	600 mm	-
700 kg	800 mm	-
750 kg	900 mm	-
1000 kg	1200 mm	600 mm
1500 kg	1800 mm	900 mm
2000 kg	-	1200 mm
2500 kg	-	1500 mm

Dynamic load (Test load 1,0 x tail lift loading capacity). For tail lifts with load centre of 750 mm

Capacity	Load 1000 kg	Load 1500 kg
	Distance out in platform (L)	
1000 kg	750 mm	-
1500 kg	1125 mm	750 mm
2000 kg	1500 mm	1000 mm
2500 kg	1875 mm	1250 mm

Test of safety functions

The tail lifts safety functions must be tested

Check:

- That the red lamp in the vehicle cabin turns off when the platform is completely closed against the body and that it turns on when the platform is opened (where applicable).
- That the tail lift will not operate if the cabin switch is in the off position.
- That the tail lift cannot be operated when the main current fuse is removed (where applicable).
- That the overflow valve is activated when the lift is run up to the floor level or armstops.
- That the tail lift cannot be lowered or tilted down respectively if the electrical connector from the lift and tilt cylinders respectively electric safety valve is removed.
- That the platforms max load marking has been included and is correctly positioned according to the loading diagram for the tail lift model concerned.
- That the warning flags are installed and fulfill their function correctly.
- That all safety and operating stickers are installed in their specified position.
- That the platform's mechanical lock functions correctly (where applicable).
- That the Operator's Handbook has been left in the driver's cabin.
- That the declaration of CE conformity has been filled in (where applicable).

12. Dismantling

1. In the event of dismantling the tail lift from the vehicle, in the case of transferring it to another vehicle, for storage or for modification please follow these instructions.
2. Support the platform by a crane or similar equipment that can safely carry the platform's weight. (NB. weight info).
3. Dismantle the tilt cylinders upper axle in the platform and rest the cylinders on the ground.
4. Run the tilt cylinders to their minimum stroke limit to remove pressure from the circuit.
5. Dismantle the tilt cylinder's lower axle at the support frame. Remove the cylinder and take away the hoses. NB. Oil can leak from the hoses and cylinder.
6. Dismantle the side profiles from the platform. Take away the grease nipples and the lock screws in the platform's axles.
Lift away the platform, lower the liftarm to the ground.
7. Unscrew the lift cylinder's upper axle at the lift arm and lower the cylinders to the ground. Take the lift cylinder's lower axle away at the support frame and remove the cylinders completely. Loosen the connected hoses.
8. Unscrew the lift arm's axles at the support frame and take away the lift arm.
9. Support the support frame from its underside with a forklift or similar equipment with sufficient loading capacity. Unscrew all bolts from the mounting brackets.
10. Check that the battery is disconnected. Unscrew the cable from the battery to the tail lift and all the cables and wires between the hydraulic unit and the control unit. Lower the support frame and remove it from the truck chassis.

How To Order Parts

Repairs should be made only by authorized mechanics using WALTCO Replacement parts.

When ordering repair or replacement parts, please include all the information asked for below. If this information is not available, a complete written description or sketch of the required part will help WALTCO identify and deliver the needed part to you.

THE FOLLOWING INFORMATION MUST BE INCLUDED:

1. SERIAL NUMBER - [WALTCO liftgate serial numbers can be found on the Specification Tag attached to the mount frame.]
2. MODEL NUMBER
3. CAPACITY
4. PLATFORM SIZE

THEN INCLUDE THE FOLLOWING INFORMATION:

5. PART NUMBERS
6. DESCRIPTION
7. QUANTITY REQUIRED

MAIL, E-MAIL OR PHONE YOUR REQUEST TO:

Waltco Lift Corp
285 Northeast Avenue
Tallmadge, OH 44278
1-800-411-5685
FAX: 1-800-411-5684
E-MAIL: parts@waltco.com

ALL PARTS ARE F.O.B. FROM THE SHIPPING FACTORY

PLEASE NOTE:

To assure you of continuing and effective quality control, our warranty policy permits replacement of hydraulic cylinders, valves and motor pump units when their factory seals are intact. Parts under warranty will be exchanged promptly after careful inspection of the returned assemblies.



Every vehicle that has a WALTCO Liftgate must have legible WARNING AND OPERATION DECALS clearly posted on the vehicle and an OWNER'S MANUAL in the vehicle at all times as a guide for proper operation and maintenance.

Additional WARNING DECALS, OPERATION DECALS and OWNER'S MANUALS can be obtained from WALTCO LIFT CORP.

NOTE:

**When ordering, give model
and serial number of the liftgate.**

IMPORTANT

WARNING

Improper operation and maintenance of this liftgate could result in severe personal injury or death.

Read and understand the contents of this manual and all warning and operation decals before operating and/or performing maintenance on this liftgate.

For SAFETY information on this liftgate see Chapter 1 of this manual