

HIAB X-HIPRO 262



HIAB X-HIPRO 262 BASIC DATA

BASIC DATA	X-HiPro 262 E-6	X-HiPro 262 E-6 Jib 45X-3	X-HiPro 262 E-8	X-HiPro 262 EP-5
Mdyn	284 kNm	285 kNm	285 kNm	284 kNm
Lifting capacity (kNm)	195	195	185	203
Lifting capacity (tm)	19,9	19,9	18,9	20,7
Lifting capacity (ADC) (kNm)	210	210	200	218
Lifting capacity (ADC) (tm)	21,4	21,4	20,4	22,3
Outreach - lifting capacity, standard (m-kg)	2,5 - 8 400	19,2 - 330	2,4 - 8 400	2,5 - 8 600
	4,5 - 4 750	20,8 - 290	4,7 - 4 350	4,5 - 4 950
	6,1 - 3 300	22,7 - 250	6,3 - 2 960	6,2 - 3 450
	7,9 - 2 360	24,6 - 230	8,1 - 2 060	8,2 - 2 480
	9,8 - 1 800		10 - 1 500	10,4 - 1 880
	11,8 - 1 400		12 - 1 120	12,7 - 1 500
	13,9 - 1 160		14,1 - 880	15 - 1 260
	16,1 - 980		16,3 - 700	18,6 - 580
Outreach - lifting capacity, manual extensions (m-kg)	18,3 - 780	-	22,4 - 440	17,2 - 1 040
	20,4 - 640			
Hydraulic outreach, standard (m)	16,2	24,7	21	15,1
Hydraulic boom extension (m)	11,7 m	14,9 m	16,3 m	10,6 m
Outreach, manual extensions (m)	20,6	0	22,6	17,3
Lifting height above installation level, hydr/man (m)	18,8 / 23,1	25,0 / 0,0	23,6 / 25,1	17,7 / 19,9
Rec. oil flow (l/min)	90 - 120	90 - 120	90 - 120	90 - 120
Working pressure (Mpa)	32,9	32,9	32,9	32,9
Oil in tank (l)	150 - 200	150 - 200	150 - 200	150 - 200
Tank capacity (l)	0 - 235	0 - 235	0 - 235	0 - 235
Slewing angle (°)	410	410	410	410
Max slope viable at full capacity (°)	5	5	5	5
Slewing torque, gross (kNm)	28,3	28,3	28,3	28,3
Slewing speed 80 (°/s)	15	15	15	15
Slewing speed (°/s)	15	15	15	15
Lifting speed at standard hydraulic outreach (m/s)	2,3	2,3	3	2,2
Height in folded position (mm)	2 633	2 633	2 401	2 650
Width in folded position (mm)	2 505	2 505	2 508	2 503
Install space required with hose and pipe kit (mm)	1 220	1 215	1 212	1 274
Crane in standard version without stabiliser system (kg)	3 210	3 700	3 540	3 000
Frame attachments (kg)	56 - 63	56 - 63	56 - 63	56 - 63
Stabiliser system (kg)	381 - 465	381 - 465	381 - 465	381 - 465

This table shows one example of a model, and represents some of all options available. With the opportunity to configure your crane, we can provide you with a crane perfectly tailored to your needs.

Please contact your local dealer for more information and the exact data on the variety of options we can offer.

Hiab X-HIPRO 262 EP-5

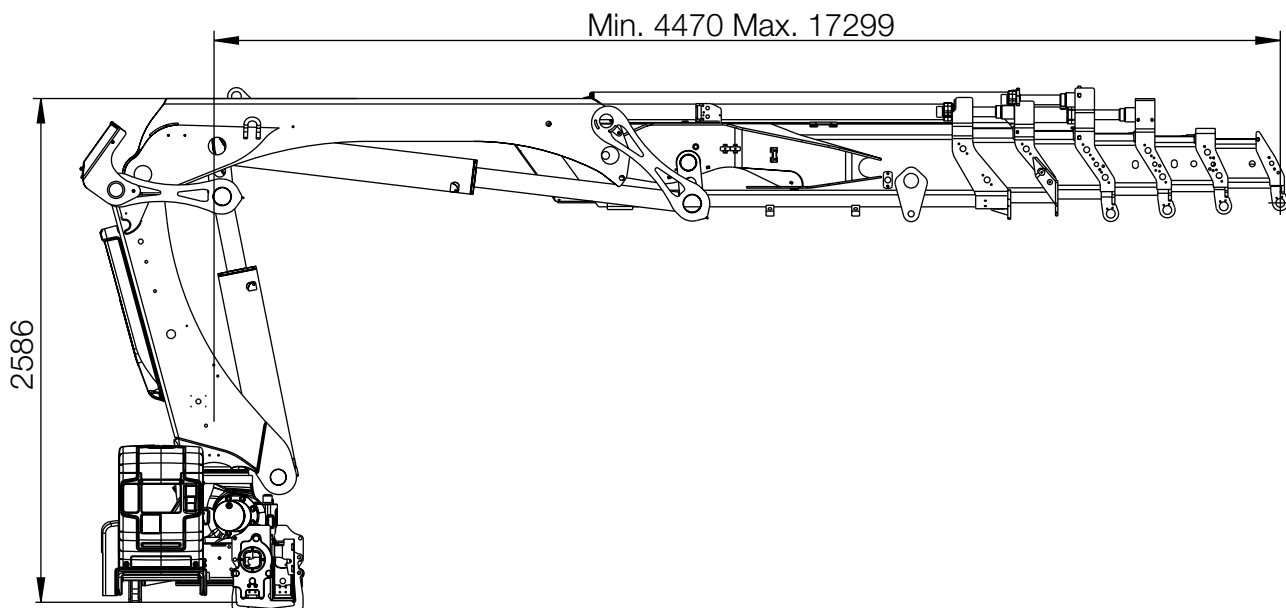
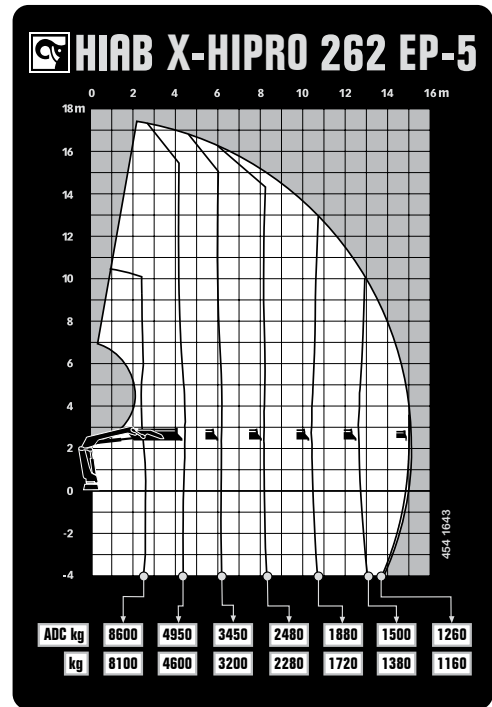
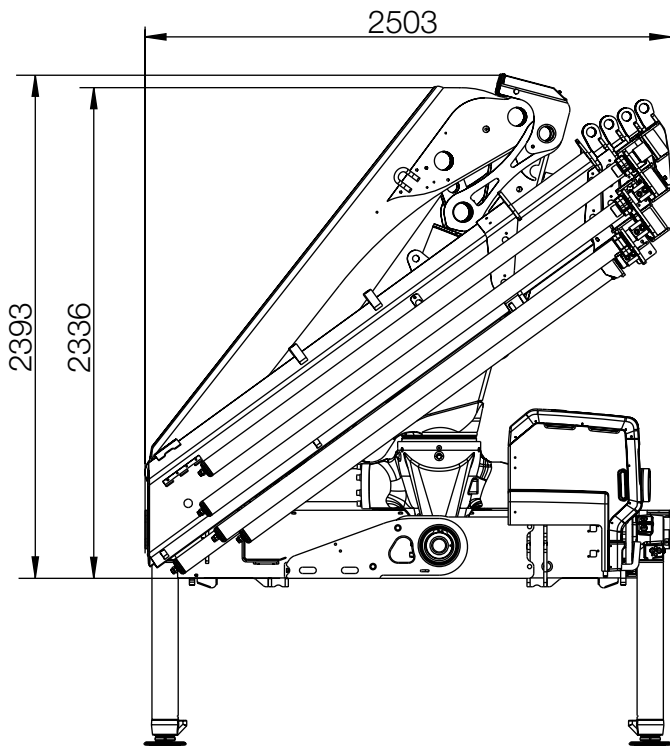

BUILT TO PERFORM

Hiab is the world's leading provider of on-road load handling equipment. Customer satisfaction is the first priority for us. Hiab's product range includes HIAB loader cranes, JONSERED recycling and forestry cranes, LOGLIFT forestry cranes, MOFFETT truck mounted forklifts and MULTILIFT demountables, as well as DEL, WALTCO and ZEPRO tail lifts.

hiab.com

Hiab is part of Cargotec.

cargotec.com



© BD-XIIPRO262-EN-VW_160806



hiab.com