

LOGLIFT 140S



LOGLIFT 140S BASIC DATA

Technical data	F140S 79	F140S 79 BOOSTER	F140S 96
Max. lifting capacity (kNm)	136	160	129
Hydraulic outreach* (m)	7,90	7,90	9,63
Hydraulic boom extension* (m)	1,59	1,59	3,20
Outreach - lifting capacity, standard (m - kg)	3.0 - 4200 4.0 - 3250 5.0 - 2650 6.0 - 2260 7.0 - 1940 7.9 - 1640	3.0 - 4500 4.0 - 3850 5.0 - 3150 6.0 - 2650 7.0 - 2280 7.9 - 1940	3.0 - 3650 4.0 - 3100 5.0 - 2550 6.0 - 2160 7.0 - 1840 8.0 - 1600 9.0 - 1400 9.6 - 1260
Slewing system	Double	Double	Double
Slewing angle (°)	425	425	425
Slewing torque, gross (kNm)	32,1	32,1	32,1
Max. slope viable at full capacity (°)	8	8	8
Max. working pressure (MPa) ¹⁾	26	30	26
Recommended oil flow – fixed pump (l/min), 1-pump	80	80	80
Recommended oil flow – fixed pump (l/min), 2-pump	2 x 80	2 x 80	2 x 80
Min. recommended oil flow – variable displacement pump (l/min)	160	-	160
Power needed at rec. oil flow (kW) - fixed pump, 1-pump	39	44	39
Power needed at rec. oil flow (kW) - fixed pump, 2-pump	77	89	77
Power needed at rec. oil flow (kW) - variable displacement pump	77	-	77
Road width (mm)	2500	2500	2500
Weight - Top seat crane with ET370 stabilizer equipment (kg) ²⁾	2180		2300

¹⁾ Pressure booster option for momentary usage possible, detailed information available at request

²⁾ Weight with fixed pump system, oil weight included

Load diagram F140S 79

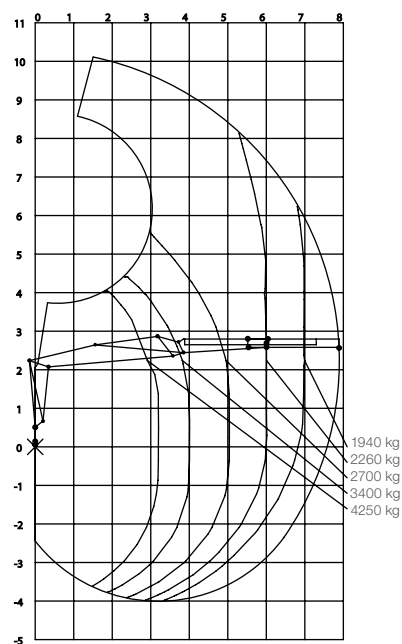

Load diagram F140S 96

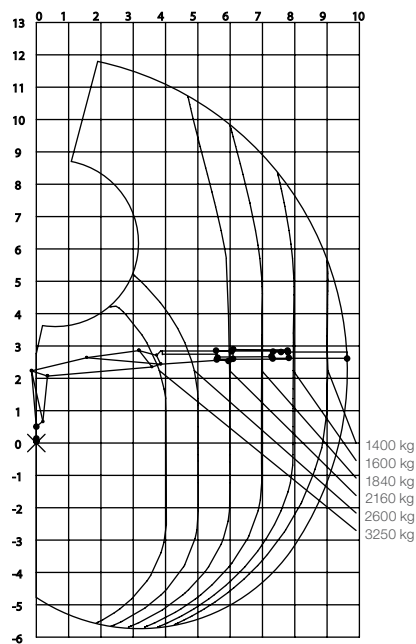

Load diagram F140S 96i

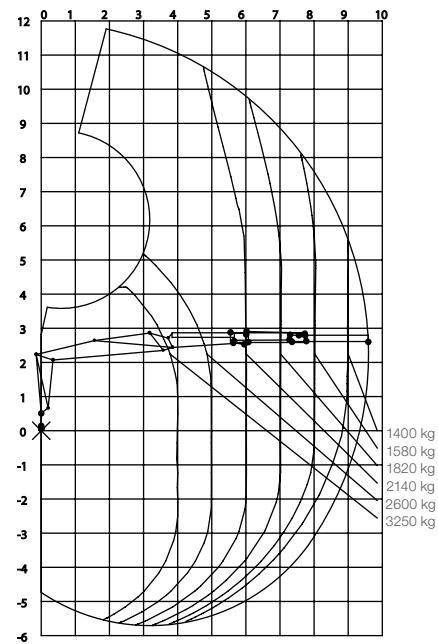

F140S 96 BOOSTER	F140S 96i	F140S 96i BOOSTER
154	129	154
9,63	9,60	9,60
3,20	3,15	3,15
3.0 - 4000 4.0 - 3700 5.0 - 3050 6.0 - 2550 7.0 - 2180 8.0 - 1900 9.0 - 1680 9.6 - 1520	3.0 - 3650 4.0 - 3100 5.0 - 2550 6.0 - 2140 7.0 - 1820 8.0 - 1580 9.0 - 1400 9.6 - 1250	3.0 - 4000 4.0 - 3650 5.0 - 3000 6.0 - 2550 7.0 - 2180 8.0 - 1900 9.0 - 1680 9.6 - 1500
Double	Double	Double
425	425	425
32,1	32,1	32,1
8	8	8
30	26	30
80	80	80
2 x 80	2 x 80	2 x 80
-	160	-
44	39	44
89	77	89
-	77	-
2500	2500	2500
	2320	

Load diagram F140S 79 BOOSTER

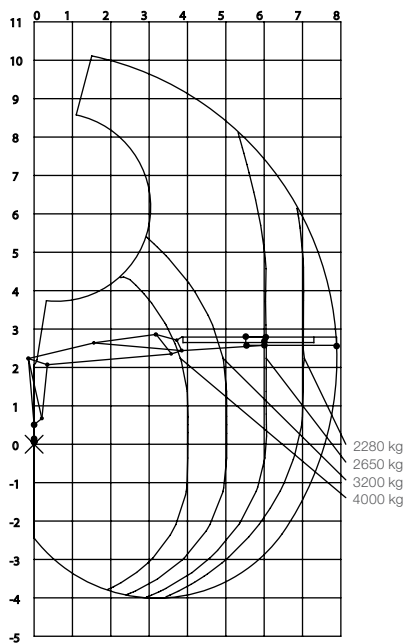

Load diagram F140S 96 BOOSTER

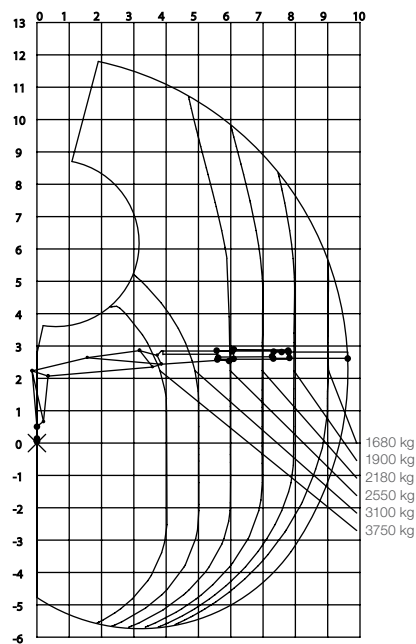

Load diagram F140S 96i BOOSTER

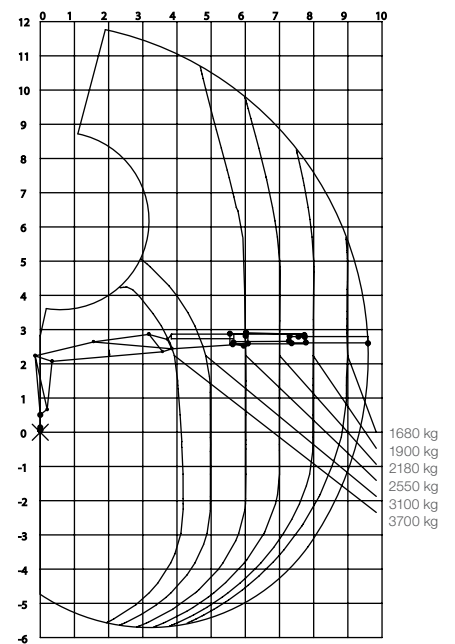

F140S Cabin

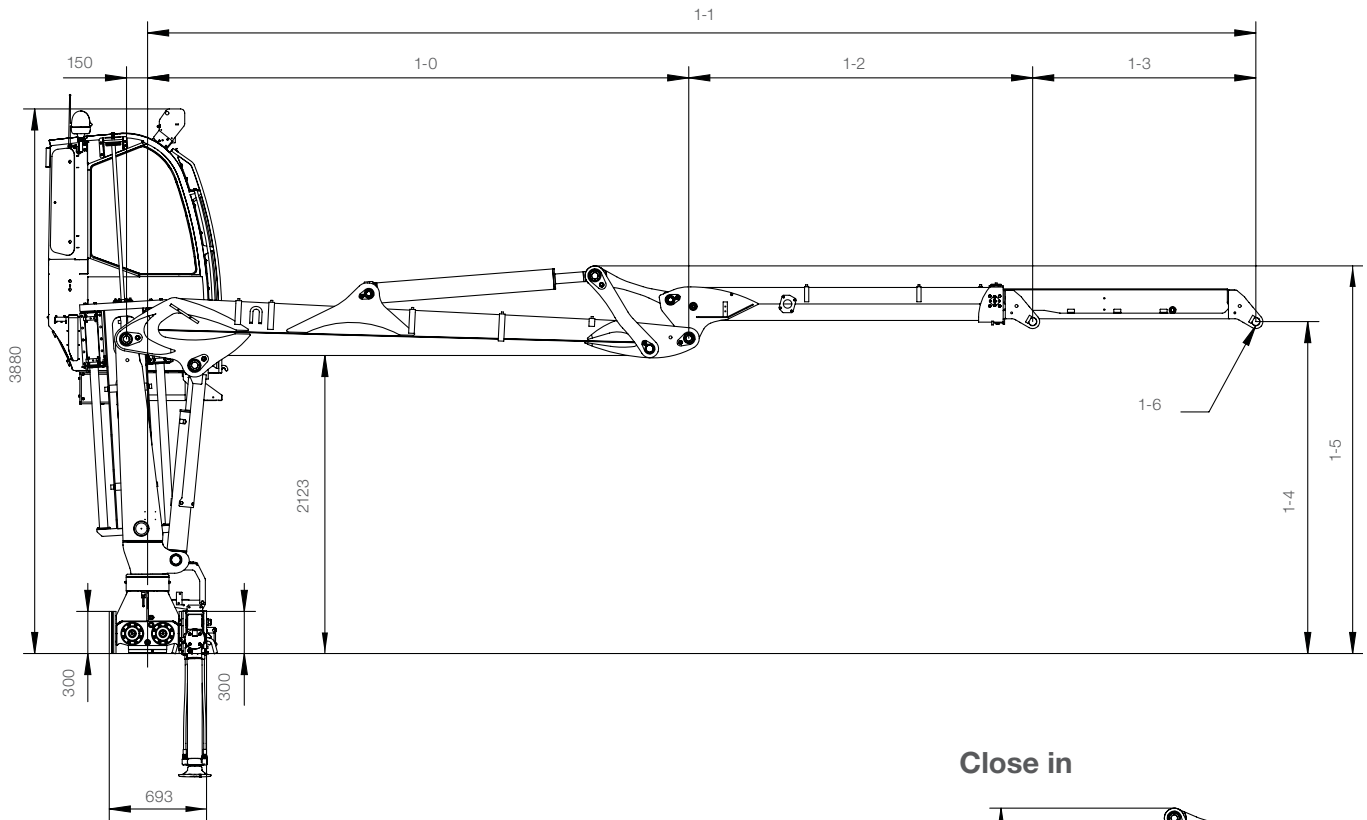

Close in

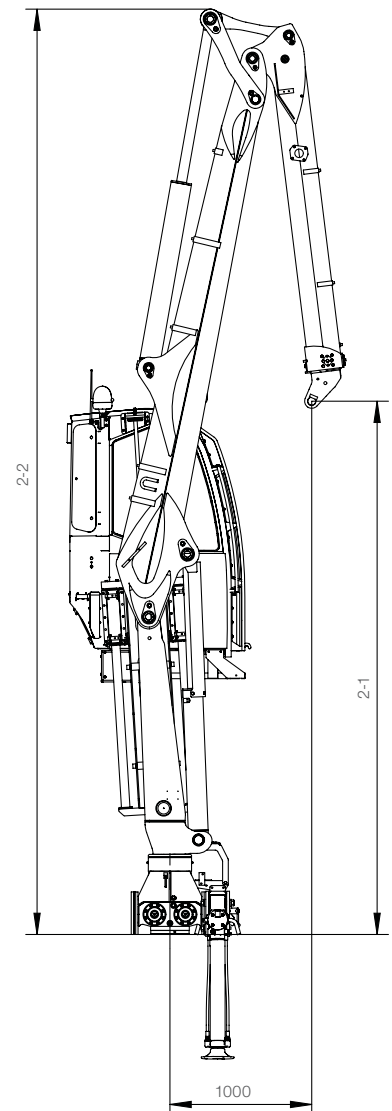

Model	1-0	1-1 min	1-1 max	1-2	1-3	1-4	1-5	1-6
79i	3855	6305	7895	2450	1590	2365	2761	Ø 40, B=184
79i	3855	6355	7945	2500	1590	2379	2761	Ø 40, B=184
96	3855	6425	9625	2570	3200	2410	2857	Ø 45, B=80
96i	3855	6445	9595	2590	3150	2398	2761	Ø 40, B=184
96i	3855	6495	9645	2640	3150	2416	2761	Ø 40, B=184

Model	2-1	2-2	HPL	HPL Nordic
79i	3761	6526	X	
79i	3709	6526		X
96	3638	6529		
96i	3617	6529	X	
96i	3566	6528		X

F140S Cabin parked

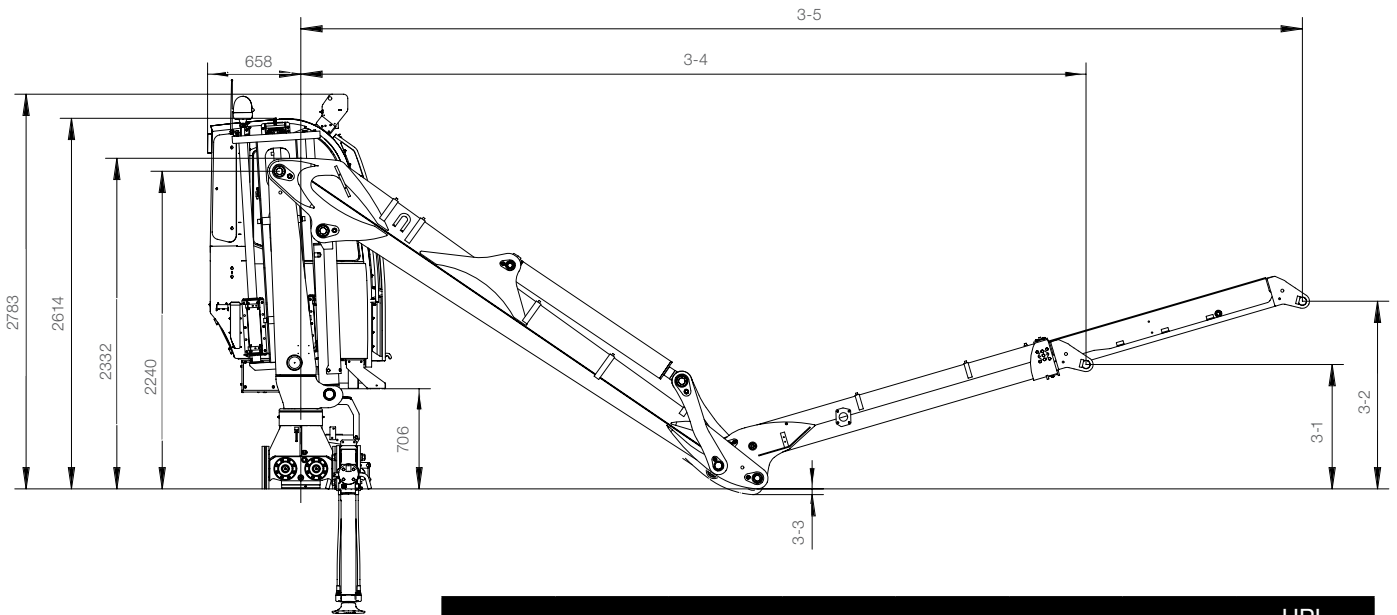

Model	3-1	3-2	3-3	3-4	3-5	HPL	HPL Nordic
79i	877	1323	40	5538	7064	X	
79i	920	1366	40	5578	7104		X
96	951	1492	40	5641	7500		
96i	946	1482	40	5664	7500	X	
96i	977	1499	40	5707	7500		X

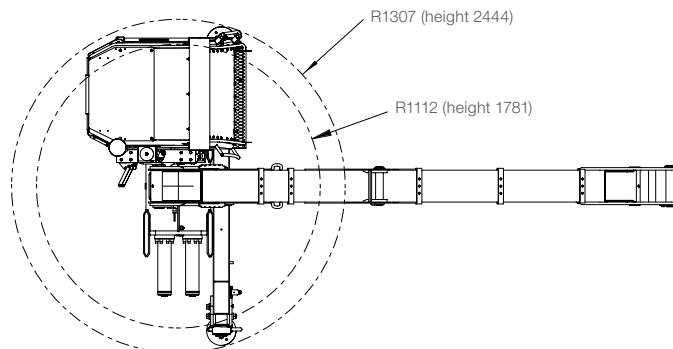
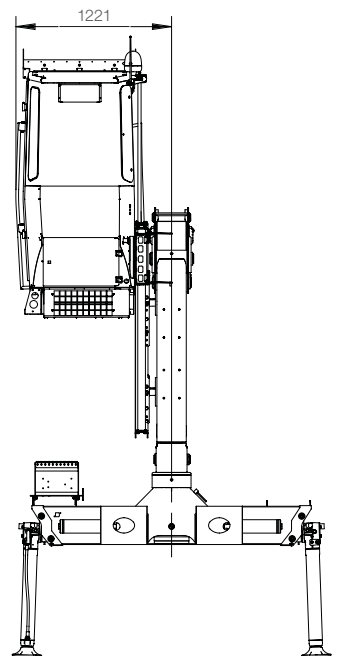
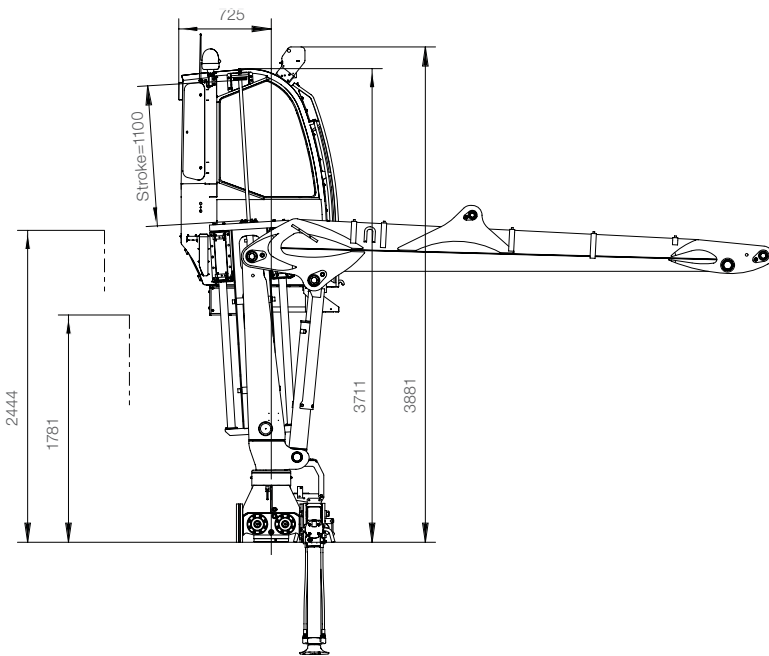

F140S Top seat

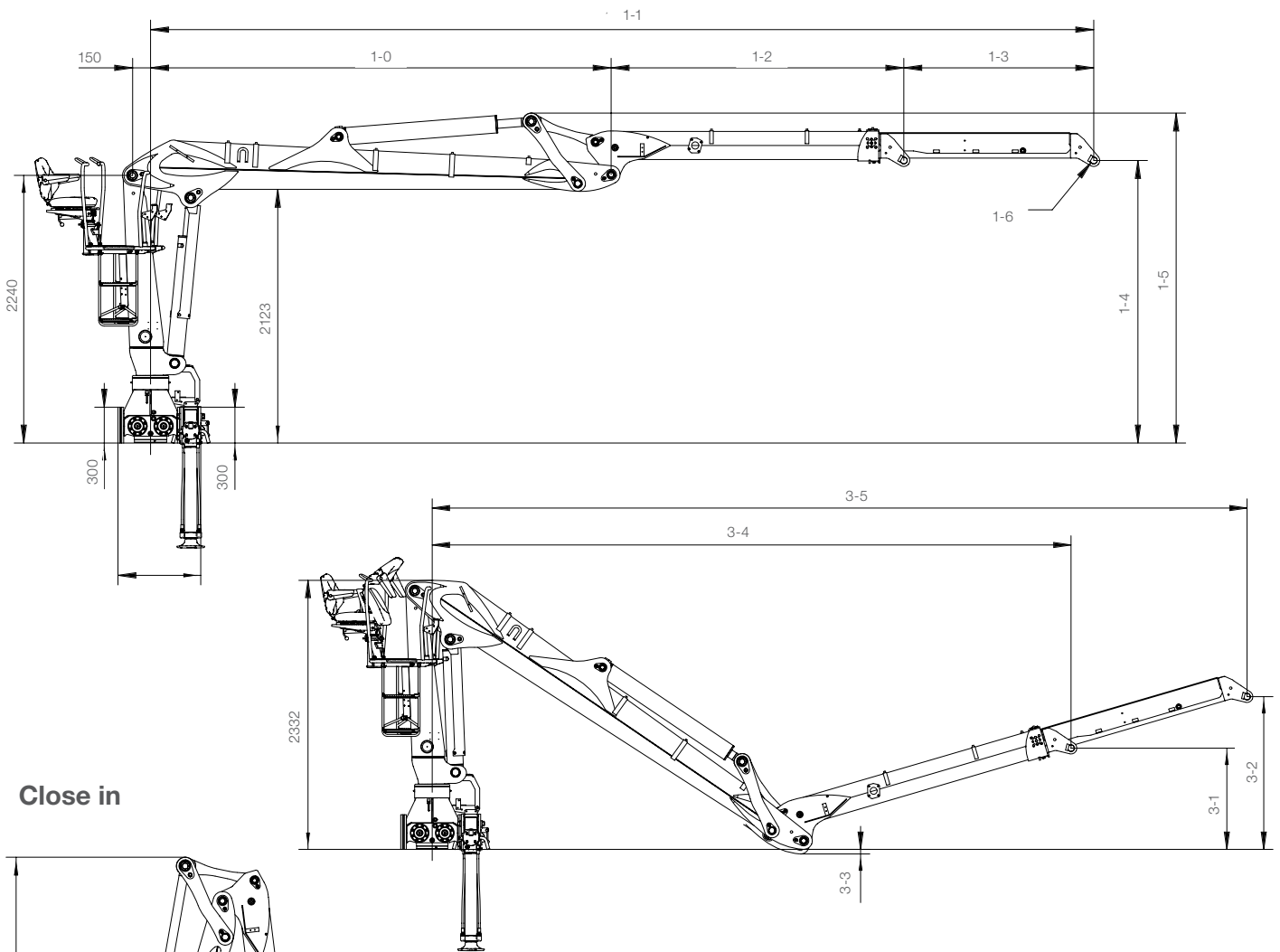

Close in

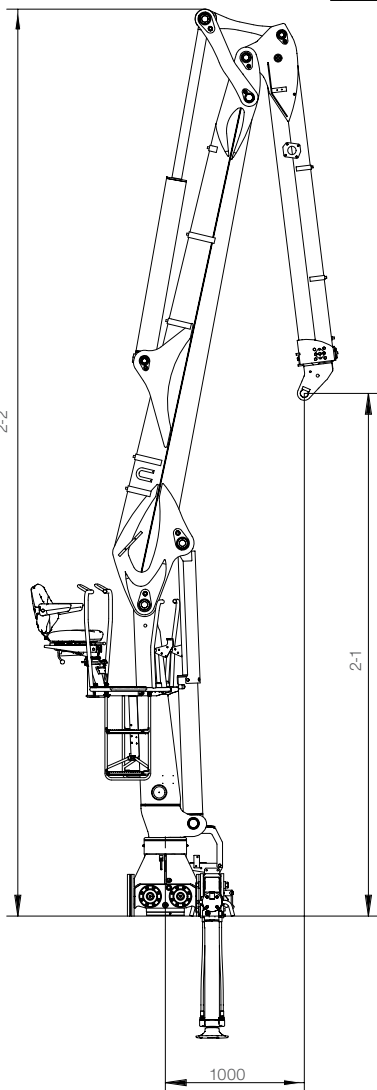

Model	1-0	1-1 min	1-1 max	1-2	1-3	1-4	1-5	1-6
79i	3855	6305	7895	2450	1590	2365	2761	Ø 40, B=184
79i	3855	6355	7945	2500	1590	2379	2761	Ø 40, B=184
96	3855	6425	9625	2570	3200	2410	2857	Ø 45, B=80
96i	3855	6445	9595	2590	3150	2398	2761	Ø 40, B=184
96i	3855	6495	9645	2640	3150	2416	2761	Ø 40, B=184

Model	2-1	2-2	HPL	HPL Nordic
79i	3761	6526	X	
79i	3709	6526		X
96	3638	6529		
96i	3617	6529	X	
96i	3566	6528		X

Model	3-1	3-2	3-3	3-4	3-5
79i	877	1323	40	5538	7064
79i	920	1366	40	5578	7104
96	951	1492	40	5641	7500
96i	946	1482	40	5664	7500
96i	977	1499	40	5707	7500

Top seat

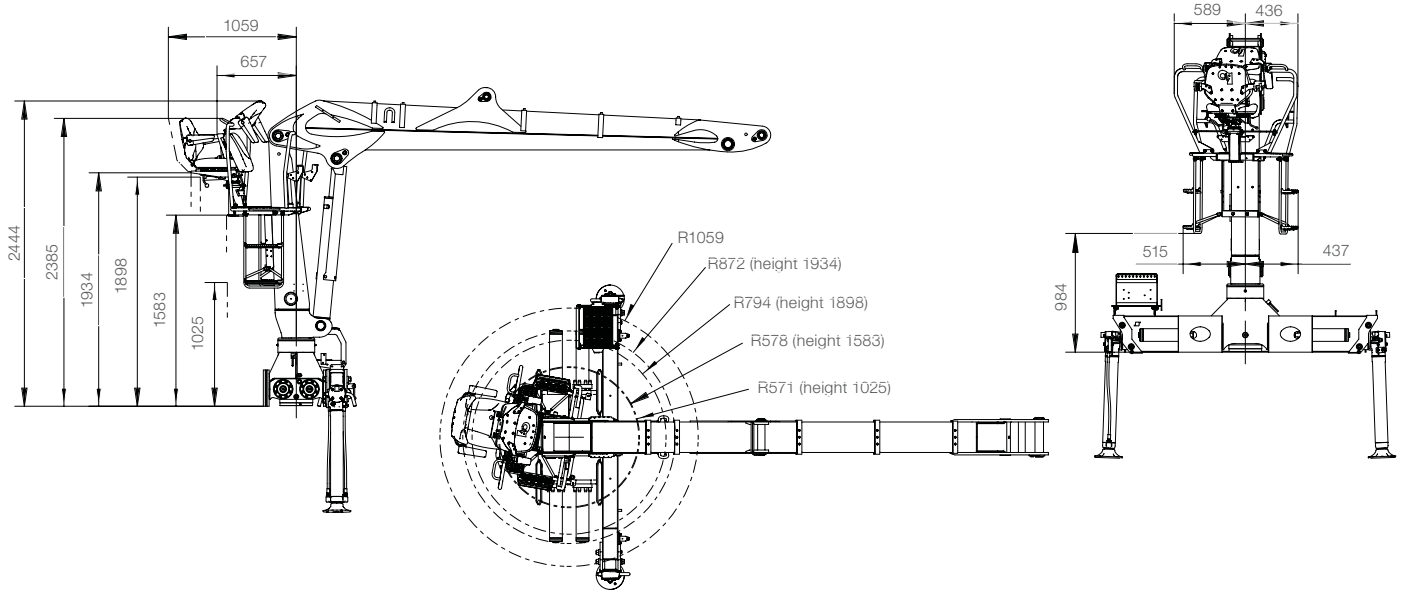

First boom (cabin)

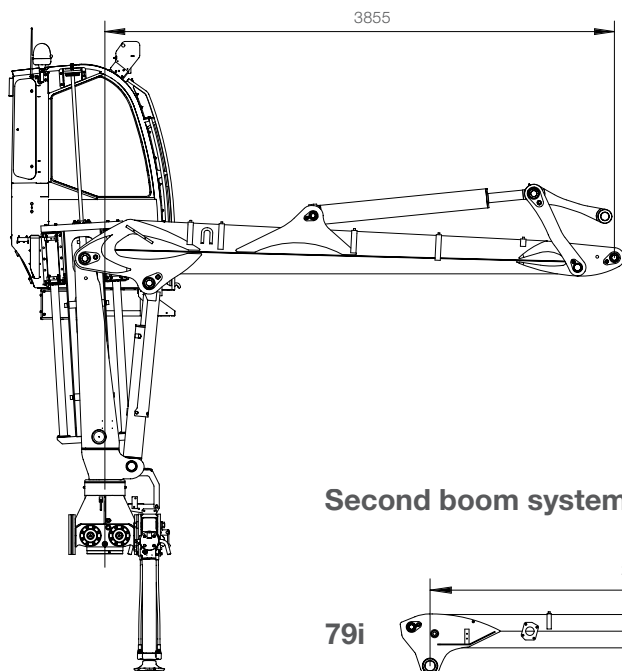

First boom (top seat)

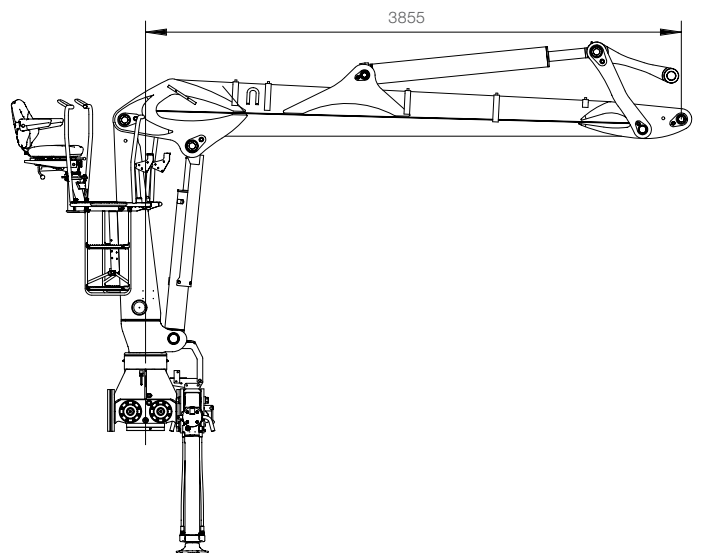

Second boom systems

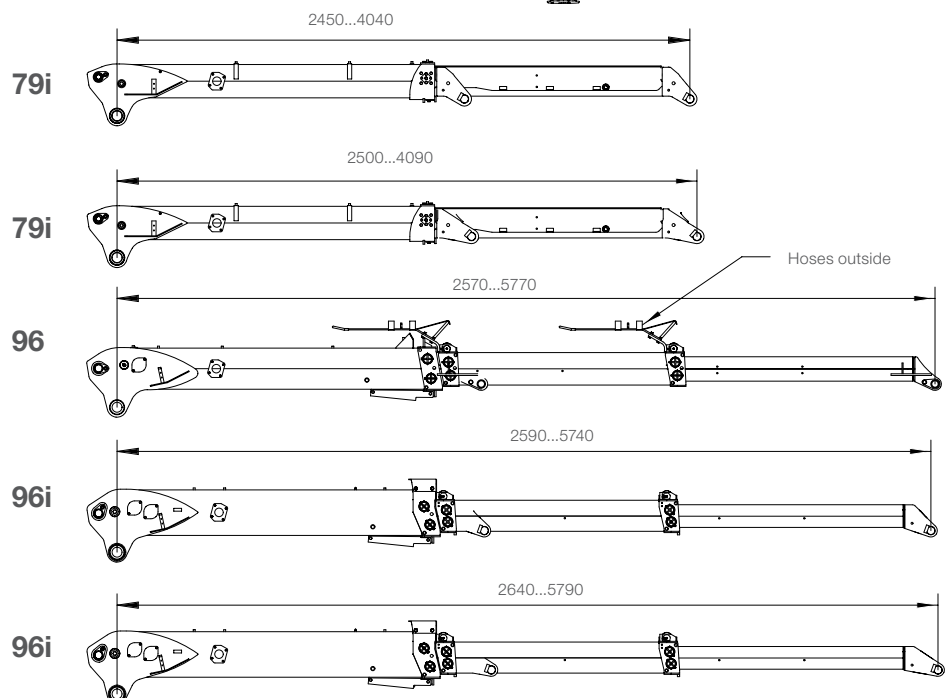

Stabilizers ET370

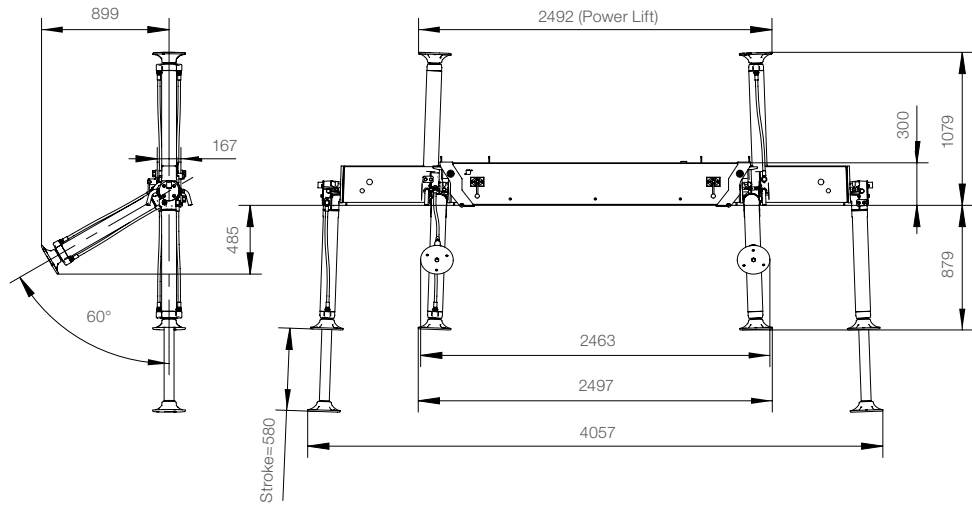

Base with stabilizers ET370

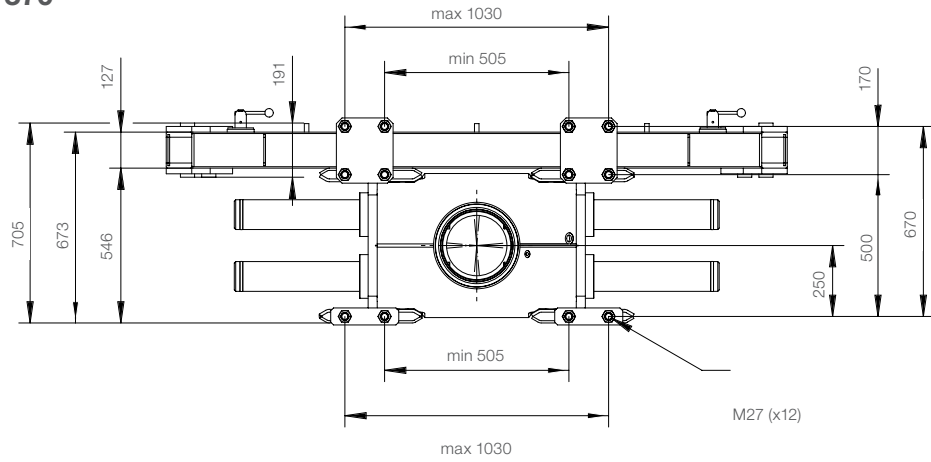

Stabilizers B4820

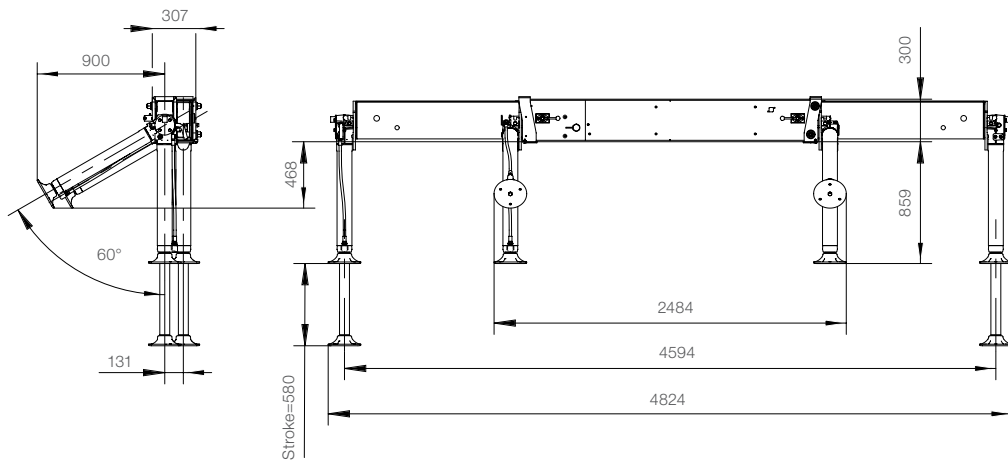

Base with stabilizers B4820

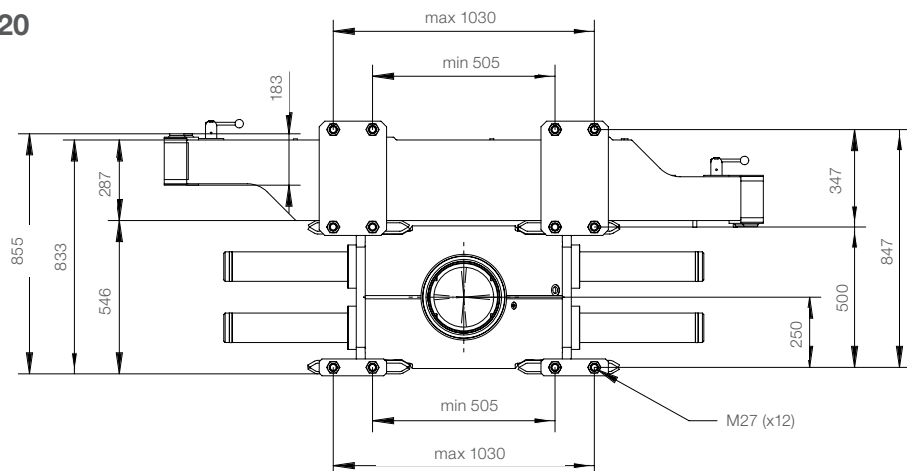

BUILT TO PERFORM

Hiab is the world's leading provider of on-road load handling equipment. Customer satisfaction is the first priority for us. Hiab's product range includes HIAB loader cranes, JONSERED recycling and forestry cranes, LOGLIFT forestry cranes, MOFFETT truck mounted forklifts and MULTILIFT demountables, as well as DEL, WALTCO and ZEPRO tail lifts.

hiab.com

Hiab is part of Cargotec.

cargotec.com

Disclaimer. We reserve the right to make changes. Illustrations, drawings and data are not always in accordance with the latest version or standard model in production. The models in the pictures may present special equipment or colours.

© TD-F140S-EN-WW_161018

