

# Complete floating crane barges



One supplier, one complete solution



# Complete crane barge solutions

MacGregor is the world's leading supplier of marine cargo cranes. Since the early 1960s, we have successfully designed and introduced a wide range of tailor-made crane types. Based on our expertise and long experience, combined with a new innovative barge design, we are able to supply complete floating crane barges according to your requirements.

In today's competitive market, fast loading and unloading is a key factor, therefore the reliability and availability of the crane barge at all times is crucial.

Efficiency and operability have a direct impact on the operator's bottom line. Our naval architects and crane experts offer the most efficient arrangements and solutions for specific operational needs.

## **Optimum performance, flexibility and efficiency**

MacGregor's complete crane barge is designed to maximise operation ability and increase the profitability. We provide reliable solutions that give optimum operational performance, availability and enhance the safety for crew and equipment. Our naval

architects have performed detailed motion studies of the complete crane barge at sea. The results show that our crane barges offer optimum performance and availability even during tough weather conditions.

The heavy-duty high performance crane is placed off the centre line of the barge which will optimise the load cycle. A counter weight system ensures the stability of the barge. Greater flexibility is possible as the vessels can berth anywhere around the barge.

The crane has a high capacity and a long outreach, up to 36 meters. It is designed according to the latest FEM rules 1001. U7-A8-Q3 equals to 1,800,000 hoisting cycles. It has a closed hydraulic system and all

motions are available simultaneously at full speed and at full load. It has automated greasing of the slewing bearing. The spacious and comfortable cabin ensures safe working conditions.

In order to achieve reliable operations, our crane barges are equipped with 2x100 per cent power generators. If it is necessary to carry out maintenance work on one generator, the equipment can remain operational, avoiding costly downtime.

The crane barges are designed for:

- Loading/unloading of Handysize to Capesize bulk carriers
- Loading/unloading of feeder barges
- Handling of bulldozers, other equipment on/off vessels as well as feeder barges.

# One supplier, one complete solution

Consult us for the entire scope and cut your administration time and costs. We take turnkey responsibility and supply the complete floating crane barges as an efficient and optimised solution package. The benefits are considerable.



## Features

- Heavy duty crane with maximised lifting capacity and outreach
- Optimised loading cycle due to off centre position of the crane
- Optimised availability with Counter Weight System

## Scope for complete crane barges

- Basic/class design according to quality standards
- Detailed design including selection of sub system makers
- Operational studies between feeder barge, crane barge and ocean going vessel in different sea states
- Site management supervision at the building yard
- Overall project management including coordination with all parties such as class, yard, sub system makers etc
- Transportation from the building yard to the transloading point (optional)
- Financial package for the complete project (optional)

## Advantages

- Turnkey supply - one supplier
- Custom-built solutions according to specific operational needs
- Optimised loading capacity (tonnes/day)
- High flexibility as the crane can reach several cargo holds simultaneously
- High reliability and availability of your operations
- Complete maintenance service of the barge including sub systems

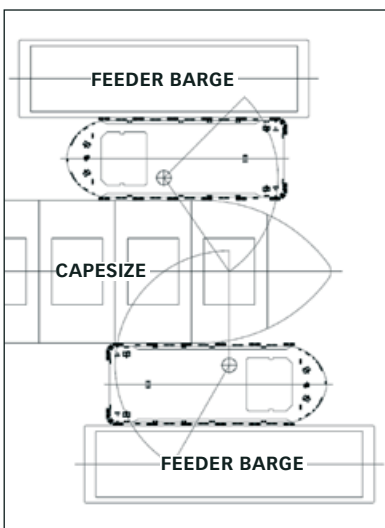
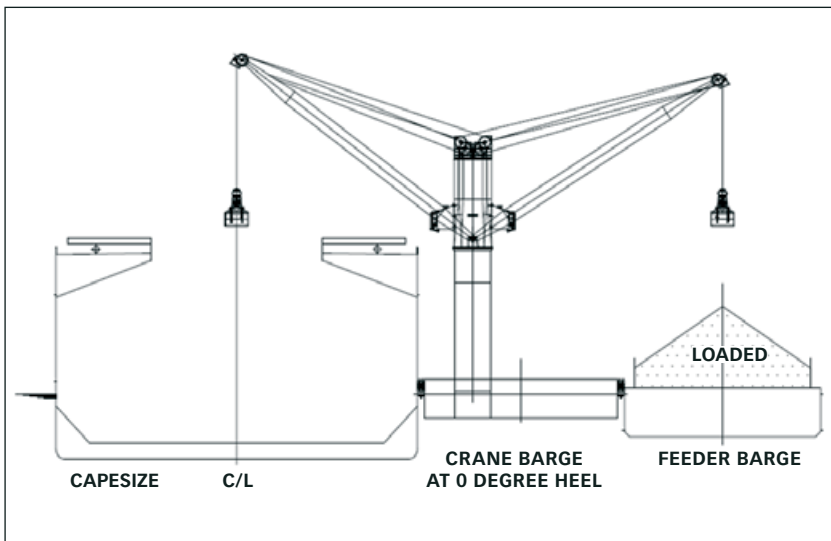

## Worldwide presence, local service

Our ambition is to ensure the operative availability of MacGregor systems. MacGregor's service organisation is on standby worldwide to provide a rapid response to your needs.

We operate in over 50 countries and our service network consists of more than 60 marine service centres in major ports around the globe, staffed by specialists. We supply original

MacGregor spare parts and repair services on a planned schedule, on demand, or on an emergency basis. Our marine services portfolio covers a wide range of service products:

- MacGregor Onboard Care (MOC) service contracts
- Planned maintenance
- On demand service
- Training for crew and personnel

## MacGregor's worldwide presence and service centres



Lloyd's Register Quality Assurance certifies that the Quality Management System for MacGregor is ISO 9001:2008 compliant.

**MacGregor** is the world's leading brand of engineering solutions and services for handling marine cargoes and offshore loads. MacGregor products serve the maritime transportation, offshore and naval logistics markets, in ports and terminals as well as on board ships. Our cargo flow solutions integrate cargo access, stowage, care and handling functions to suit a particular ship's cargo profile. This benefits its productivity, environmental impact and profitable service lifetime.

MacGregor is part of Cargotec.

Published by MacGregor. Copyright © MacGregor February 2014. All rights reserved. No part of this publication may be reproduced, stored, photocopied, recorded or transmitted without permission of the copyright owner.



**MacGregor Sweden AB  
Cranes**

Sjögatan 4G  
SE-891 85 Örnsköldsvik  
Sweden

tel. +46-660-29 40 00  
cranes@macgregor.com

[www.macgregor.com](http://www.macgregor.com)